

WARRANTY

- 1.We strive to offer high-quality products,and we also try our best to satisfy each and every customer that orders from us with product or service as needed.
- 2.We provide 30 days warranty starting from the time you receive the item.Each customer must provide a record of their order such as the order number,or item receipt for an items that are out of the warranty period you may also still receive.
- 3.Replacement parts by purchasing them with our company if they are available.

Are you having difficulty
With assembly?Missing parts?
Please send email with your order No to
customerservice@hulalahome.com

For return,please check the return policy with
the retailer or market place you bought from.

Appreciate your purchasing from us.
Pop up your life by our furniture piece!

HULALA

H O M E

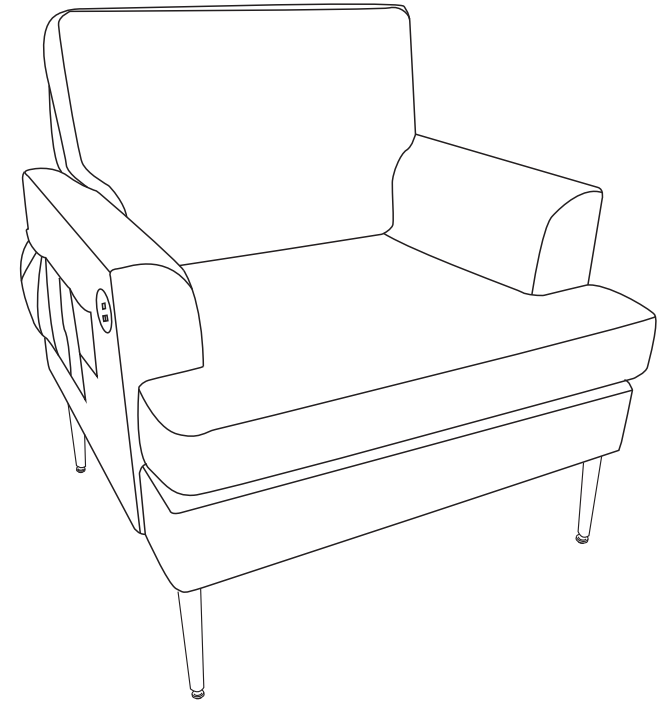

ITEM NO.CHM1122

NOTE:





This brochure contains IMPORTANT safty info. Please read
and keep for future reference.

MAINTAINANCE AND WARNING





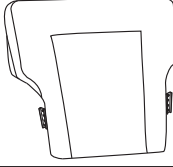
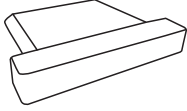

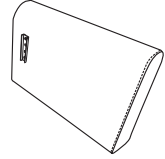
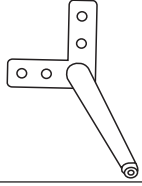
- 1.Keep furniture away from heat sources.
- 2.Do not clean furniture with harsh cleaner or polishes.Do not use detergents,solvents,abrasives,spray packs or leather cleaner. Use non-color mild soa with warm water to clean spills(Mix 1:10 soap to water).
- 3.Do not place furniture under direct sunlight,material will possibly fade over time.
- 4.Do not use on site dry cleaning machine.Children should not climb or jump on the furniture.
- 5.Do not write on furniture that is not protectedby a padded barrier.
- 6.Not for commercial use,only for residential use.







PARTS LIST

A	x1	B	x1	C	x1	D	x1
							
Back Cushion		Seat Cushion		Backrest		Seat Frame	
E	x1	F	x1	G	x4		
							
Right arm		Left arm		Legs			

HARDWARE LIST

#1	x16	#2	x8	#3	x9	#4	x1	#5	x1	#7	x1
											
Bolt M6*20		Bolt M6*50		Flat washer		Allen Key M6		Charger		Bolt M6*65	

HARDWARE SPARE LIST

#1	x1	#2	x1	#3	x1	#6	x1	#7	x1
									
Bolt M6*20		Bolt M6*50		Flat washer		Adjust the leg		Bolt M6*65	

ASSEMBLY INSTRUCTIONS

STEP-1

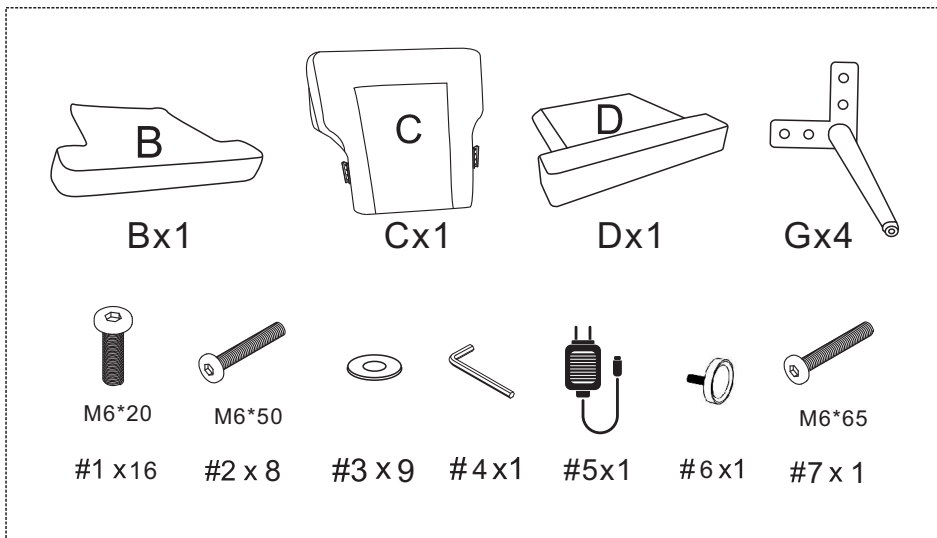
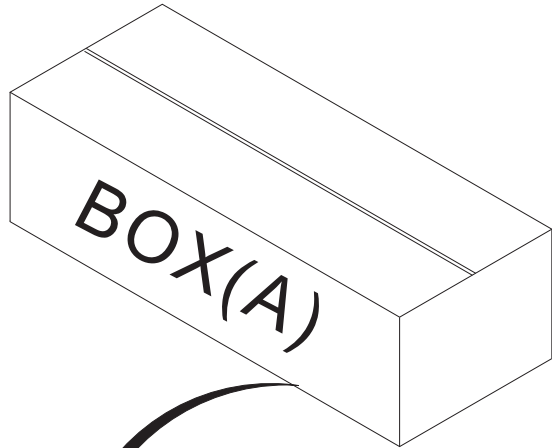

ASSEMBLY INSTRUCTIONS

STEP-2

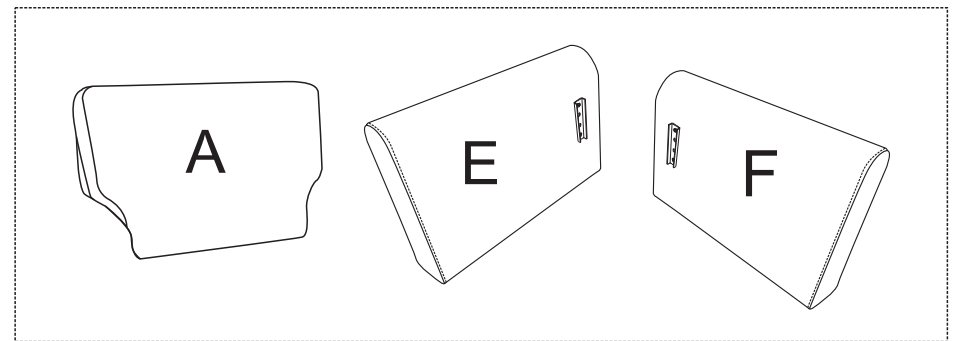
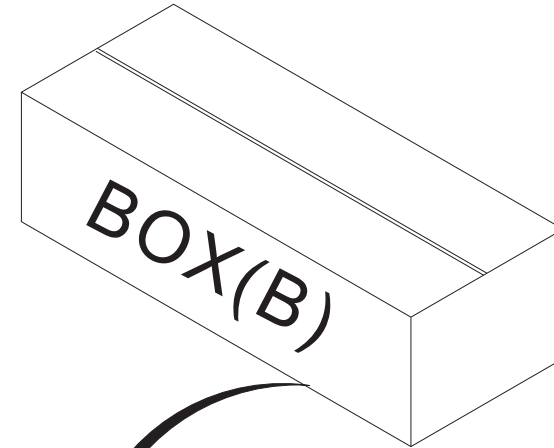

ASSEMBLY INSTRUCTIONS

STEP-3

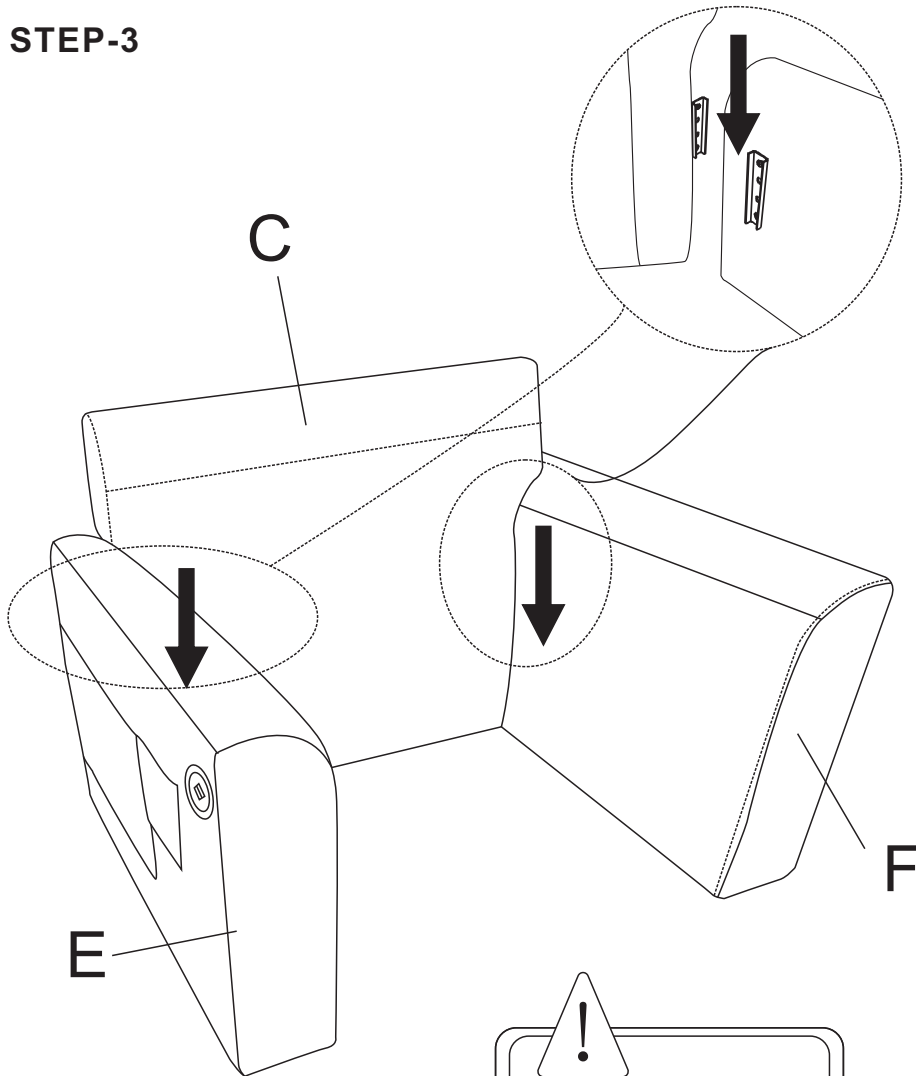





!
Please insert the Back Cushion holder into the armrest socket

ASSEMBLY INSTRUCTIONS

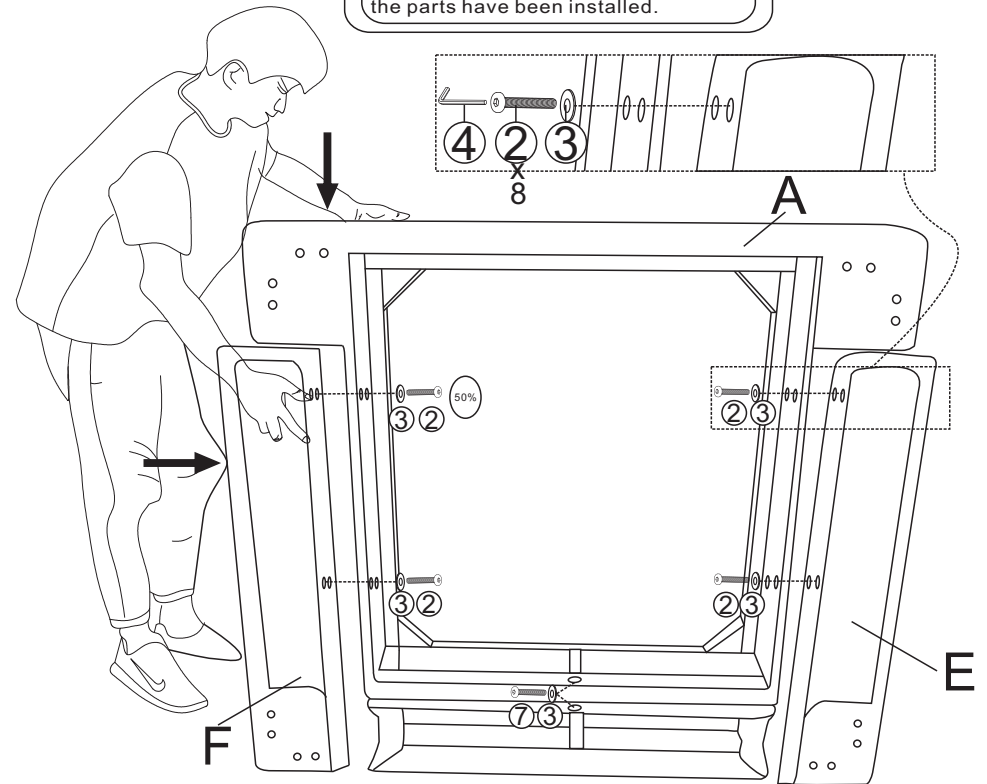
STEP-4

!
Please turn the insert over, then press your hand down and press your leg to the front to make the insert close. Tighten the screw by 50% first, then tighten the insert by 100% after all the parts have been installed.





# 7	x1	#2	x8	#3	x9	#4	x1
							
Bolt		Bolt		Flat washer		Allen Key	
M6*65		M6*50				M6	

ASSEMBLY INSTRUCTIONS

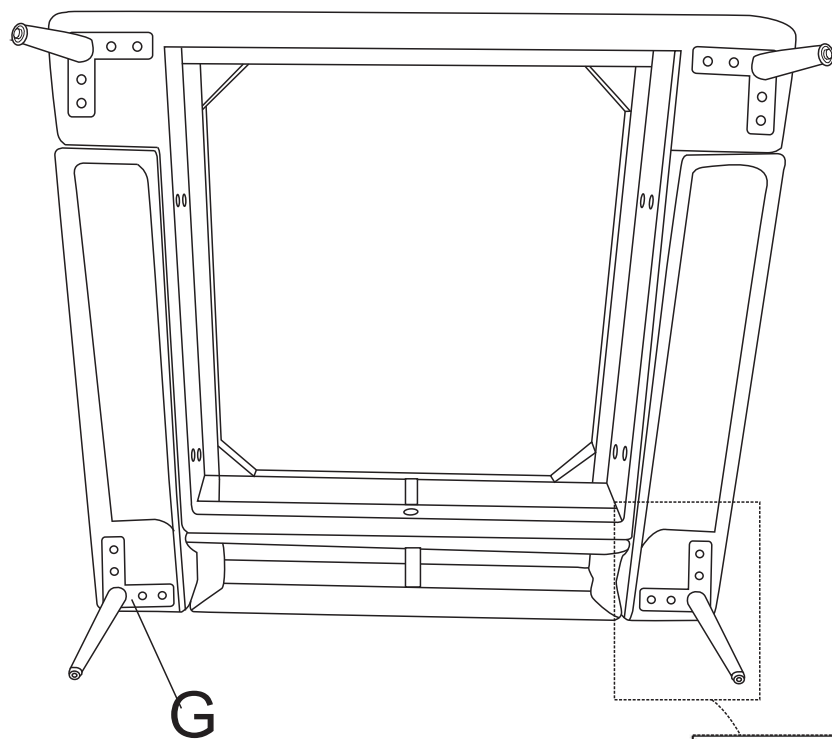
STEP-5



#1	x16
	
Bolt	
M6*20	

#4	x1
	
Allen Key	
M6	

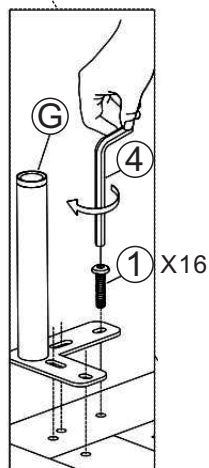

ASSEMBLY INSTRUCTIONS

STEP-6

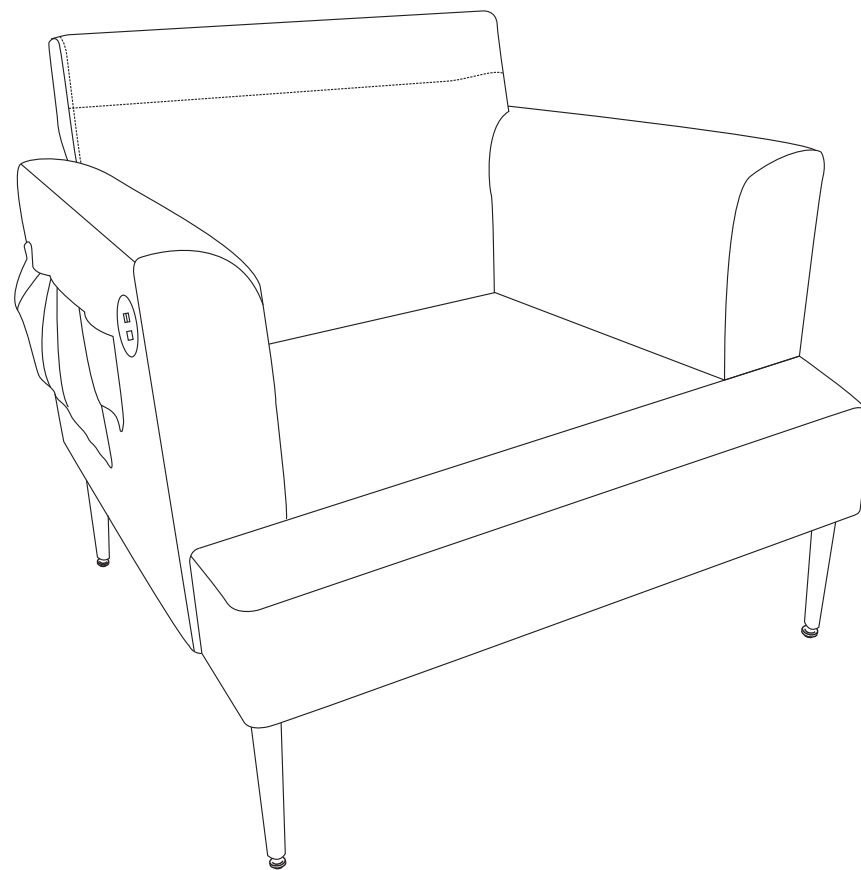

ASSEMBLY INSTRUCTIONS

STEP-7

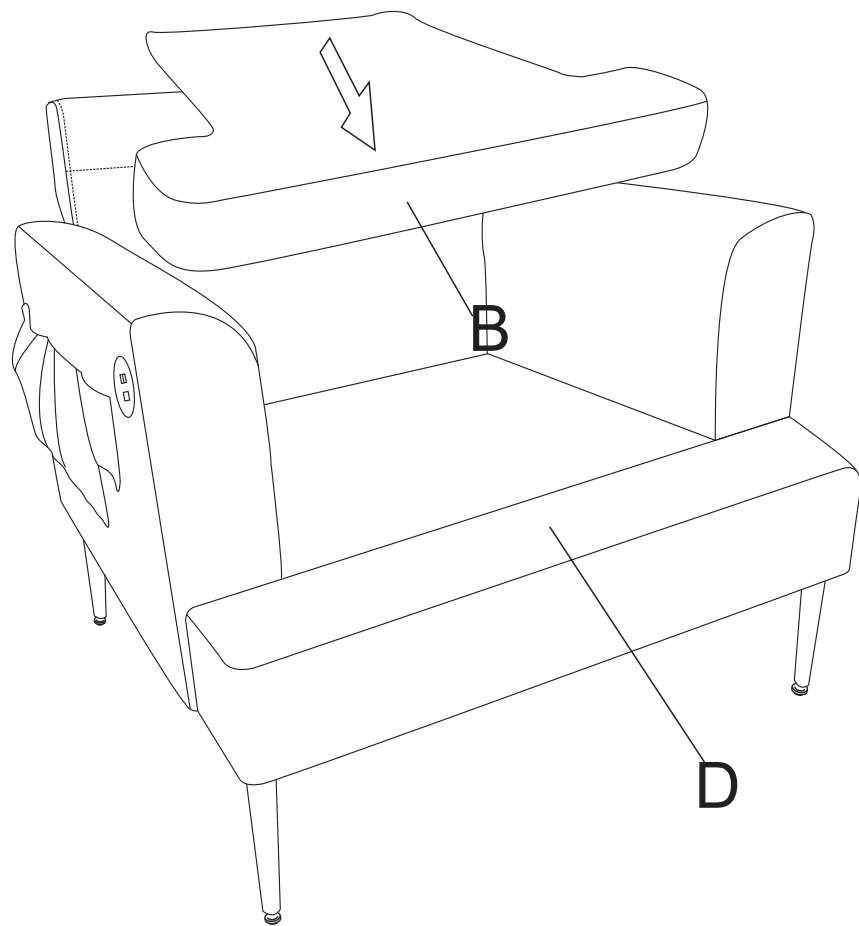

ASSEMBLY INSTRUCTIONS

STEP-8

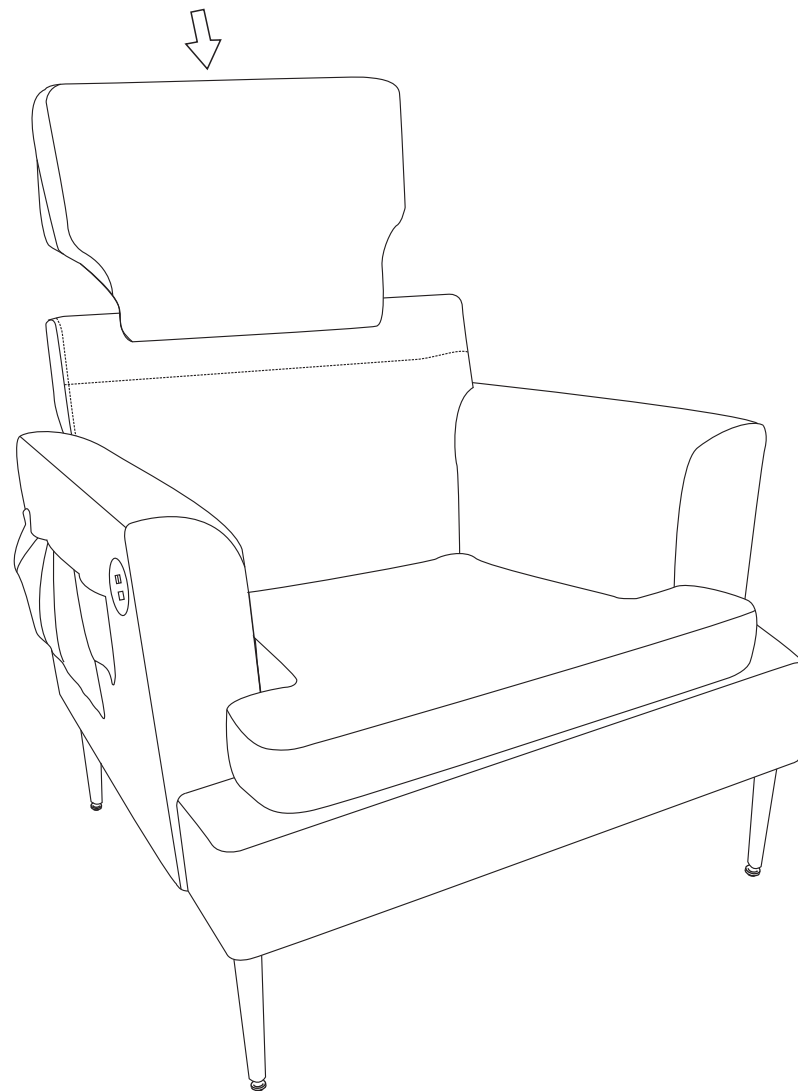

ASSEMBLY INSTRUCTIONS

STEP-9

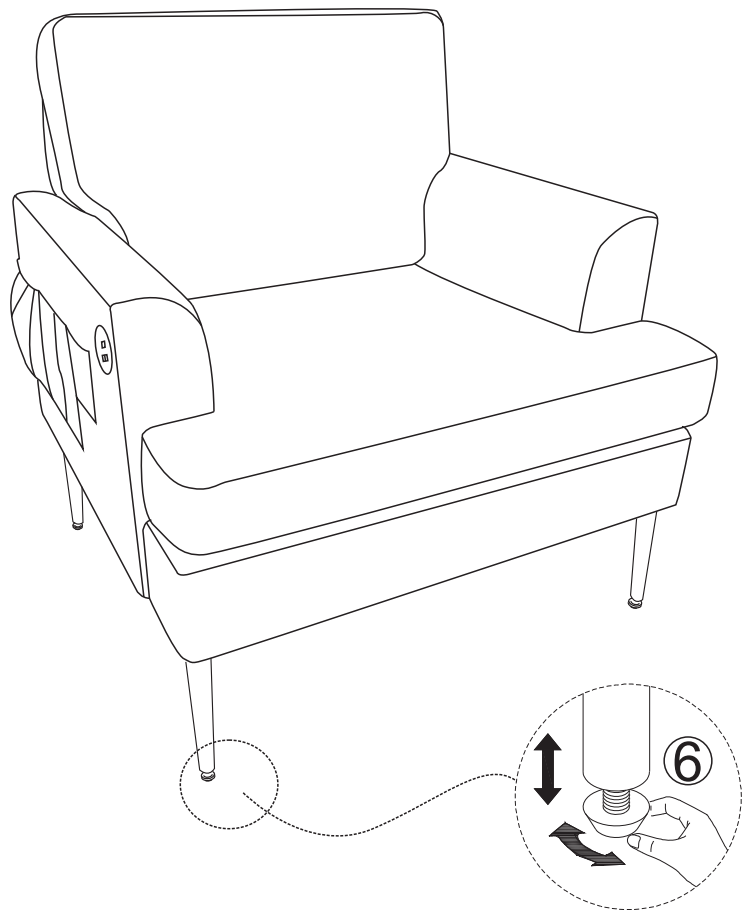

Attention:

After installation, adjust the adjustable leveler to keep the chair balanced.

ASSEMBLY INSTRUCTIONS

STEP-10

