

WARRANTY

We strive to offer high-quality products, and we also try our best to satisfy each and every customer that orders from us with product or service as needed. We provide 30 days warranty starting from the time you receive the item. Each customer must provide a record of their order such as the order number, or item receipt for any items that are out of the warranty period you may also still receive replacement parts by purchasing them with our company if they are available.

Are you having difficulty with assembly? Missing parts?

Please send email with your order No
customerservice@hulalahome.com

For return, Please check the return policy with the retailer or MarketPlace you bought from.

Appreciated your purchasing from us.
Pop up your life by our furniture piece!

HULALA

H O M E

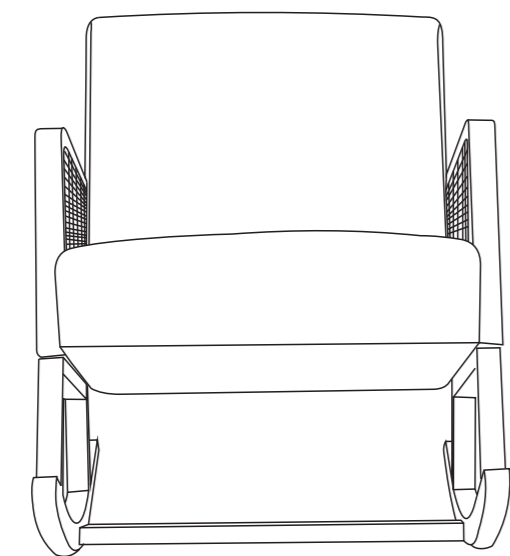

ITEM NO. HRKS0281

NOTE:

This brochure contains IMPORTANT safty info. Please read and keep for future reference.

MAINTAINANCE AND WARNING

- Keep furniture away from heat.
- Do not clean furniture with harsh cleansers or polish. Do not use detergents, Solvents, abrasives, spray packs or leather cleaner. Use non-color mild soap with warm water clean spills(Mix 1:10 soap to water)
- Do not place furniture under direct sunlight, material will possibly fade overtime.
- Do not use on site dry Cleaning machine.
- Children should not climb or jump on the furniture.
- Do not write on furniture without a padded barrier to protect the surface.
- Not for commercial use, For residential use only.



Weight Limitation

250LBS

PARTS LIST

A * 1

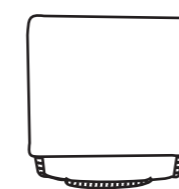

B * 1

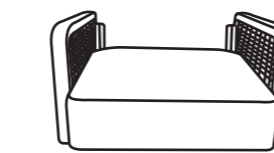

C * 1

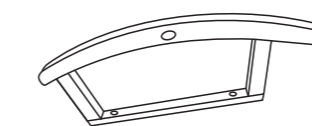

D * 1

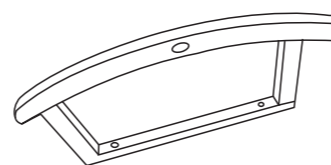

E * 1

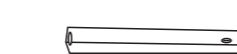

HARDWARE LIST

F * 4

M6*37MM



G * 1



H * 6



I * 2

M6*50MM



SPARE

F * 1



H * 1



I * 1



Be sure to check all packing material carefully for small parts, which may have come loose inside the carton during shipment.

ASSEMBLY INSTRUCTIONS

STEP 1: Carefully align male and female metal bracket then push chair back all the way down to secure.

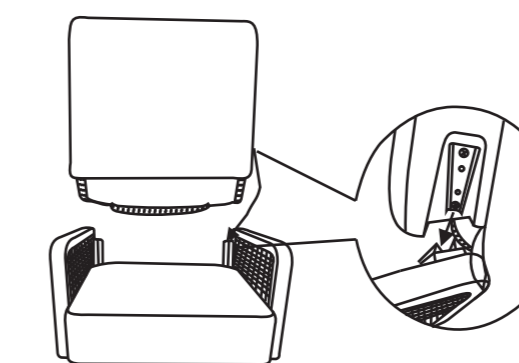

STEP 2: Smooth the flap down cover on back side, carefully match the velcro belt and press to secure.

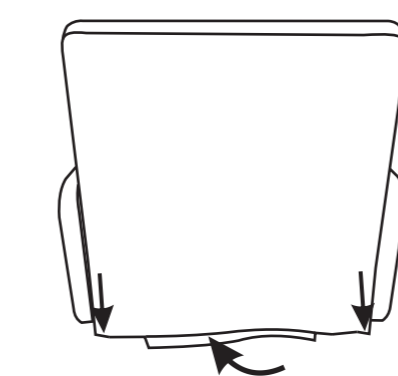

STEP 3: Use bolt F, flat washer H, allen key G to attach side frame C & D to bottom of the seat, but please don't fasten any bolt until next step.

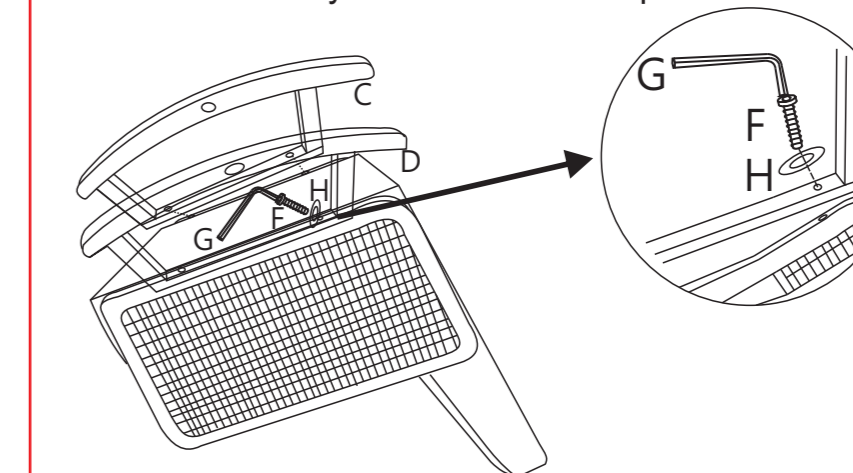

STEP 4: Use bolt I, allen key G to connect stretcher E with side frame C & D. Make sure all parts align and the whole chair set leveled then fasten all bolts to secure.

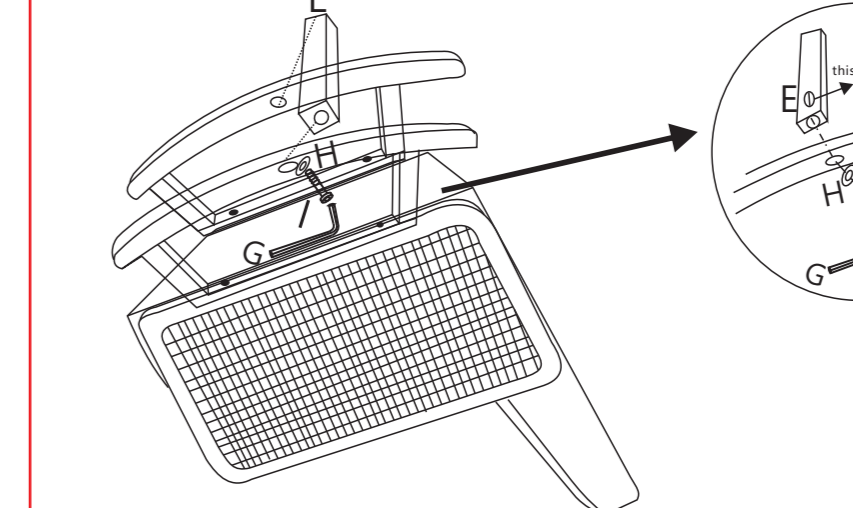

For velvet:With help of adult partner, Iron the fabric cover to stretch the wrinkles and dent mark with steam iron while necessary,please separate with a towel before ironing..

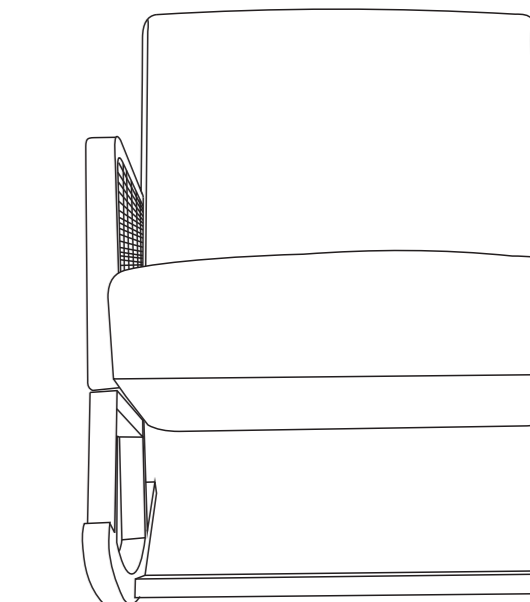

Assembly completed.

8

1

2

3

4

5

6

7