

# HULALA

---

H O M E

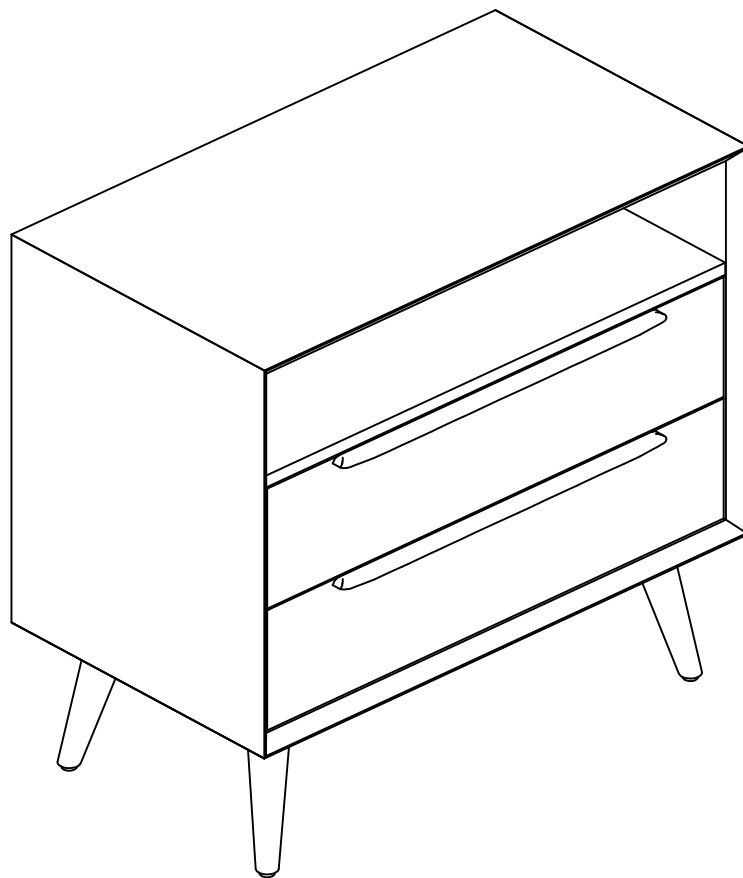

**ITEM NO.NSHM0847**

---

**NOTE:**

This brochure contains IMPORTANT safety info. Please read and keep for future reference.

---

# MAINTAINANCE AND WARNING

- 1.Keep furniture away from heat sources.
- 2.Do not clean furniture with harsh cleaner or polishes.Do not use detergents,solvents,abrasives,spray packs or leather cleaner. Use non-color mild soa with warm water to clean spills(Mix 1:10 soap to water).
- 3.Do not place furniture under direct sunlight,material will possibly fade over time.
- 4.Do not use on site dry cleaning machine.Children should not climb or jump on the furniture.
- 5.Do not write on furniture that is not protectedby a padded barrier.
- 6.Not for commercial use,only for residential use.

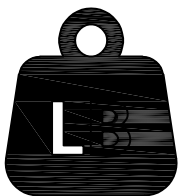

Weight Limitation  
**150 LBS**



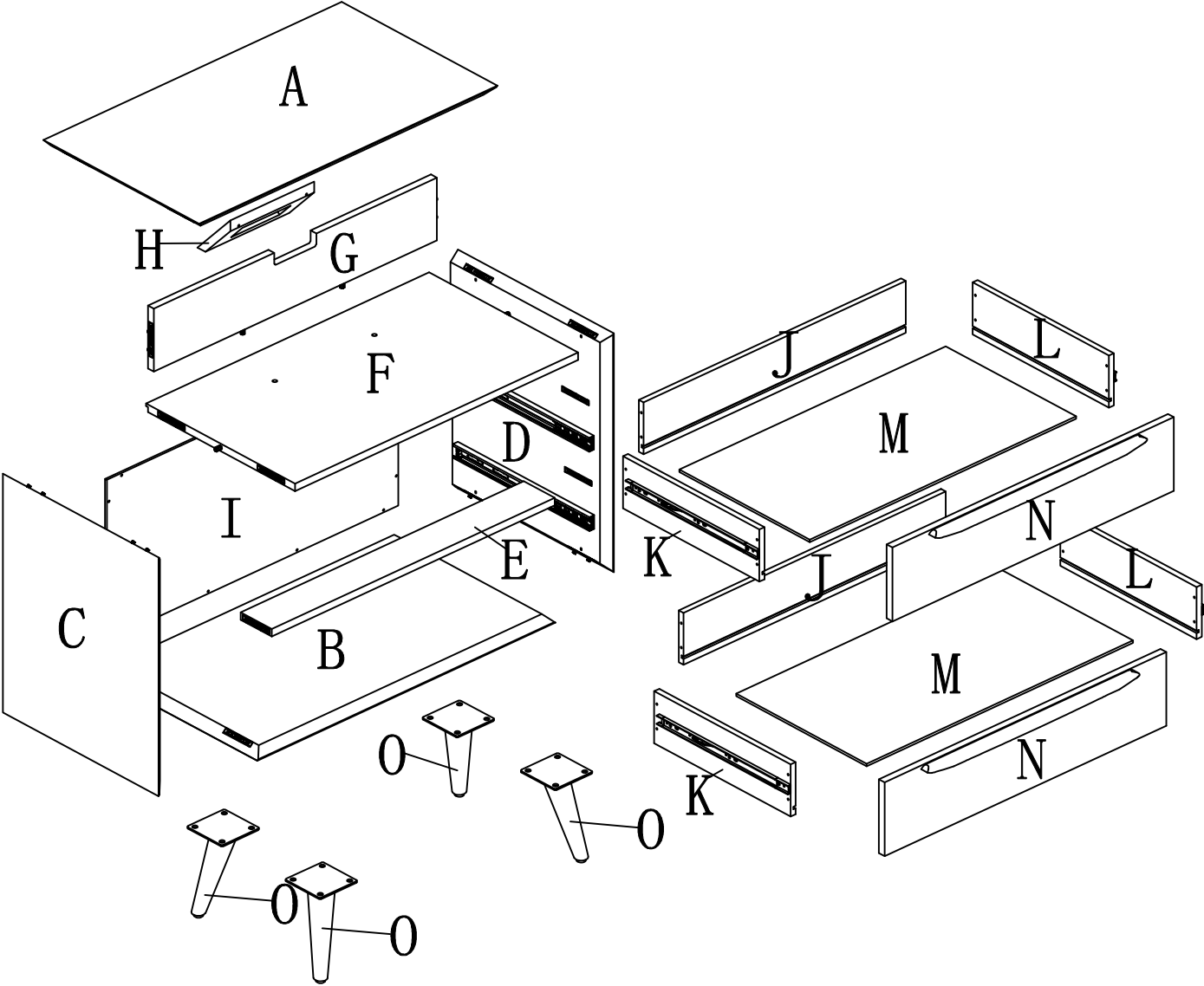

# EXPLOSIVE VIEW

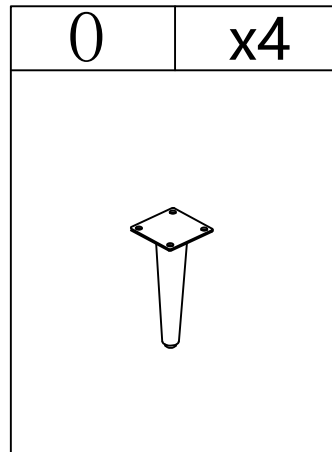
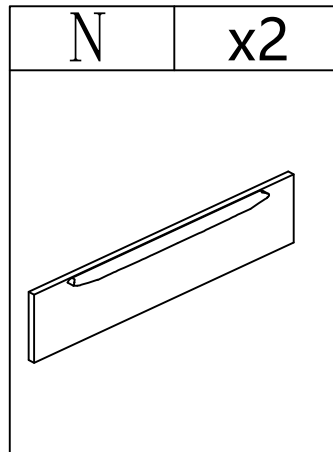
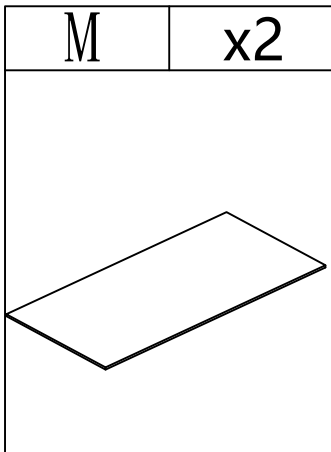
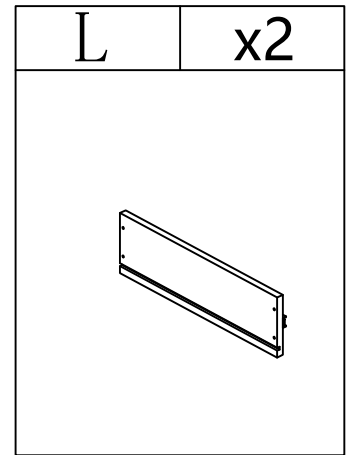
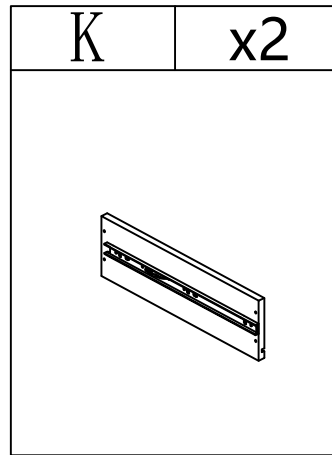
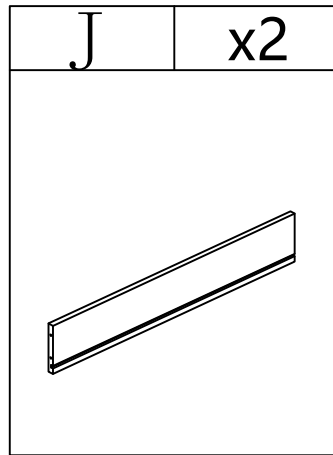
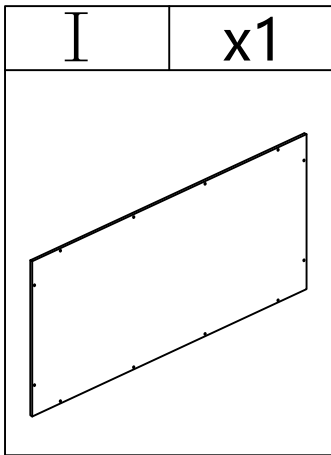
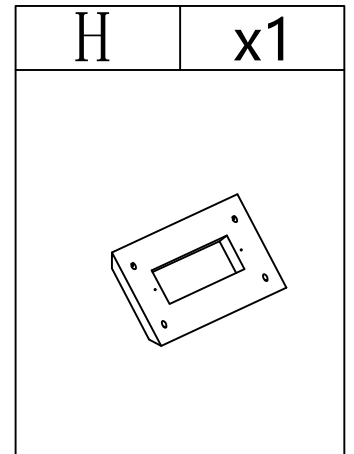
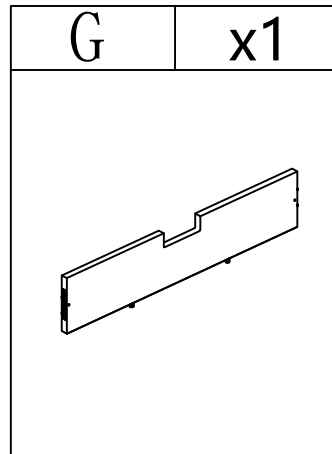
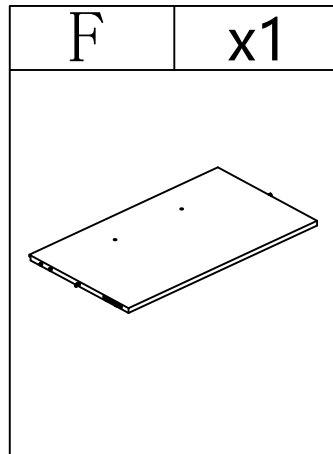
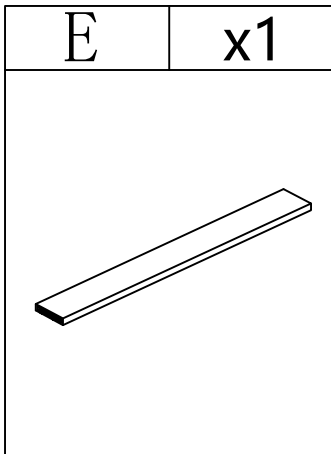
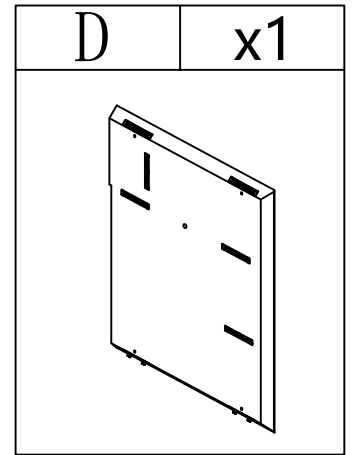
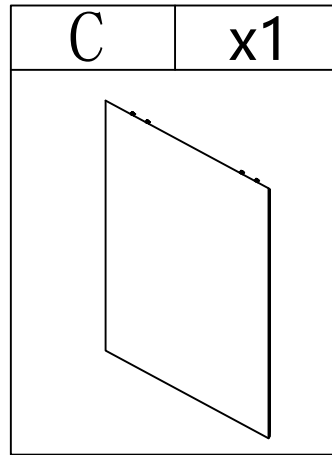
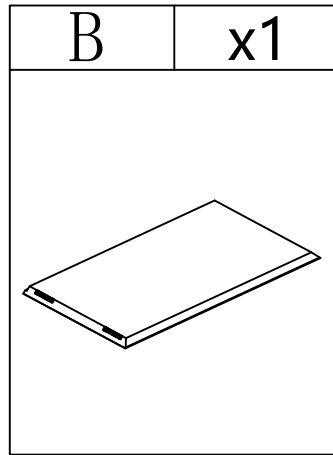
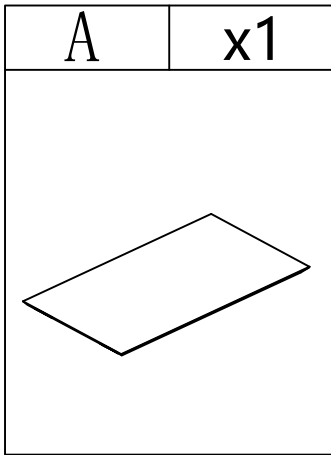

# PARTS LIST

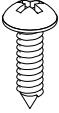

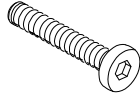
# HARDWARE LIST

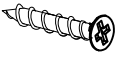
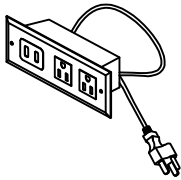
#1	x12	#2	x16	#3	x16	#4	x16	#5	x4	#6	x2
											
φ3*14mm		φ1/4"		φ1/4"		φ1/4"*1/2"		φ8#*1"		φ3*12mm	
#7	x16	#8	x1								
											
φ8#*1"											

# TOOL LIST

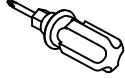
#9	x1	#10	x1
			
M4			

# HARDWARE SPARE LIST

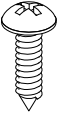
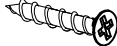
#1	x1	#7	x1
			

# ASSEMBLY INSTRUCTIONS

## STEP-1

1. Insert part (G) into part (F), make sure all holes align .
2. Insert panel (F & G) into panel (C), make sure all holes aligned and then tighten it with allen key #9 as picture show.

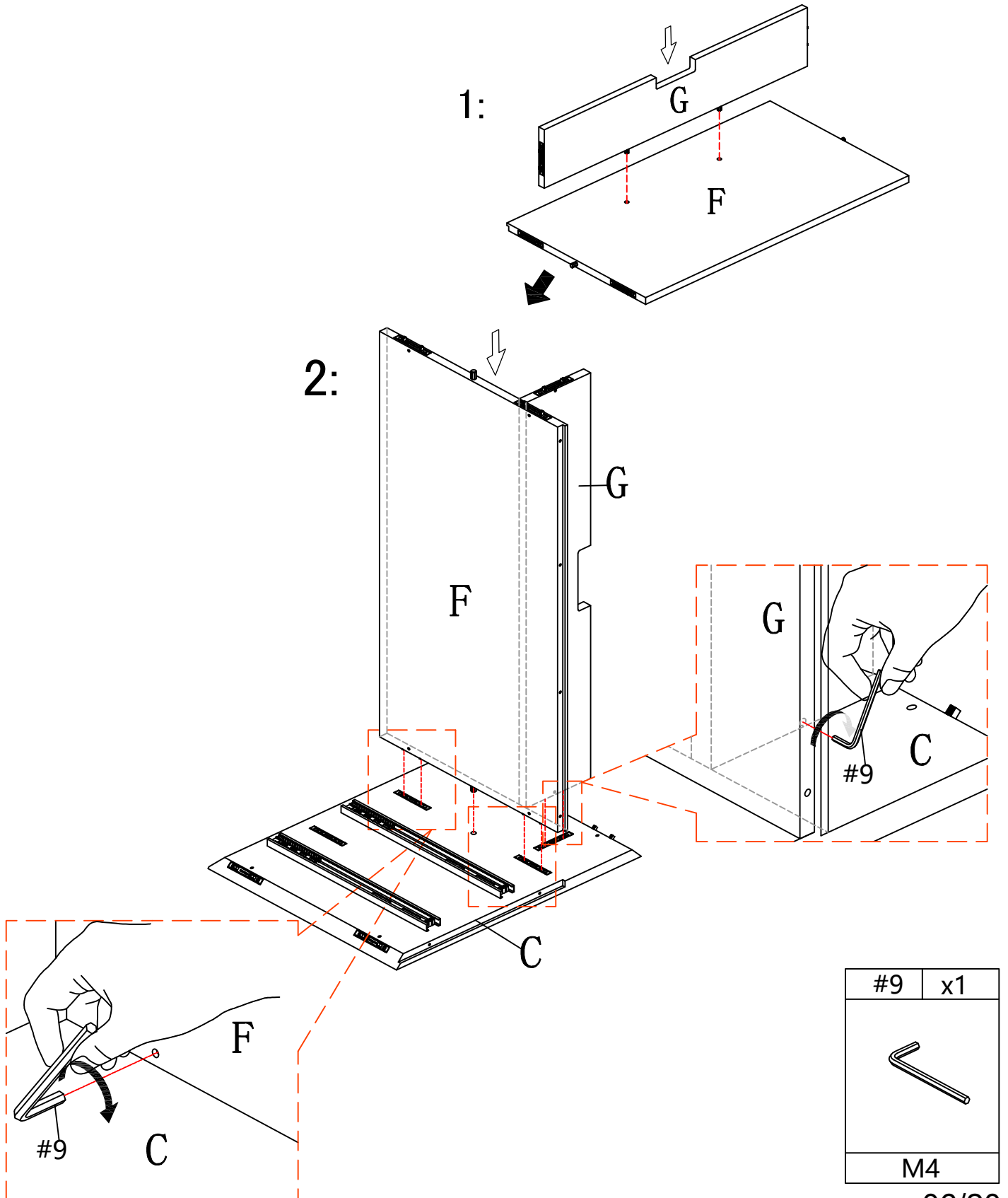

# ASSEMBLY INSTRUCTIONS

## STEP-2

1. Insert panel (E) into panel (C), make sure all holes aligned and then tighten it with allen key #9 as picture show.

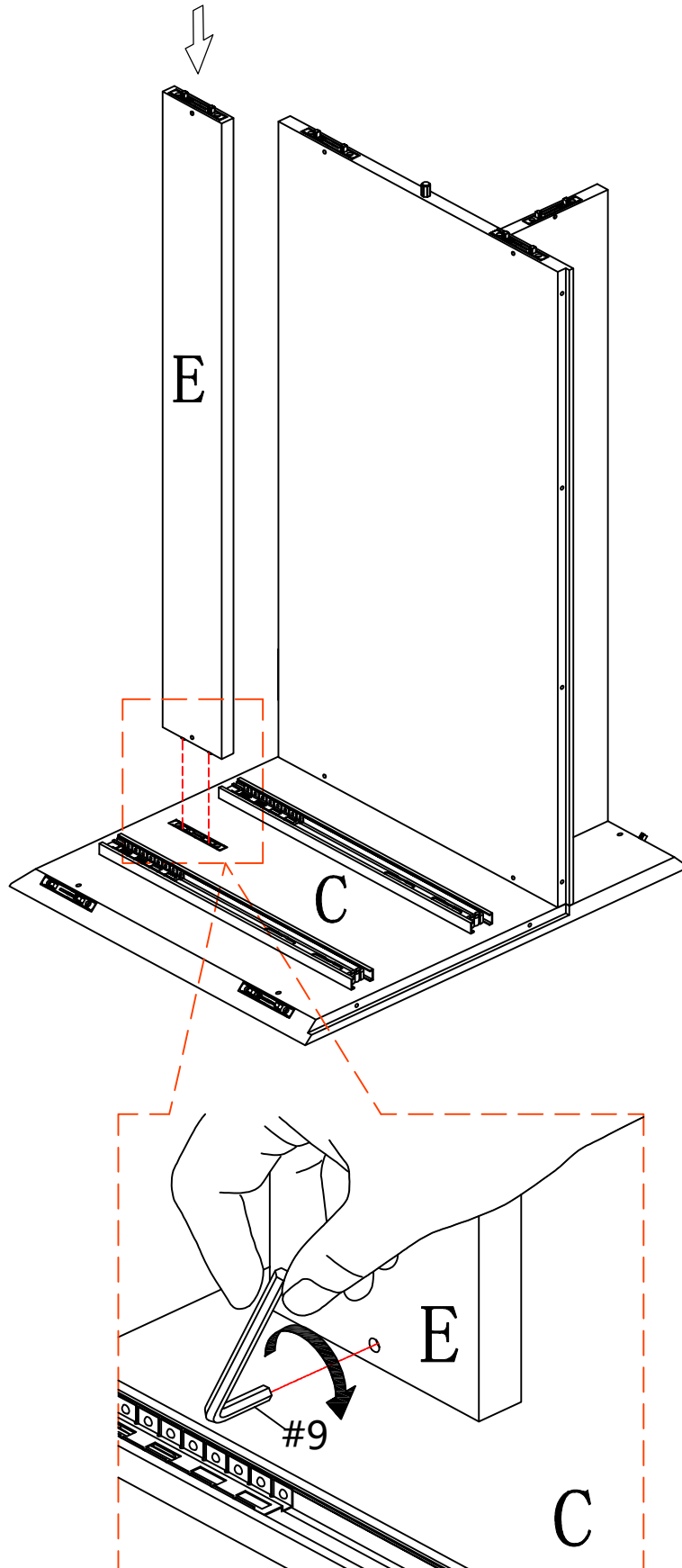

#9	x1
	
M4	

# ASSEMBLY INSTRUCTIONS

## STEP-3

1. Insert panel (A) into panel (C), make sure all holes aligned and then tighten it with allen key #9 as picture show.

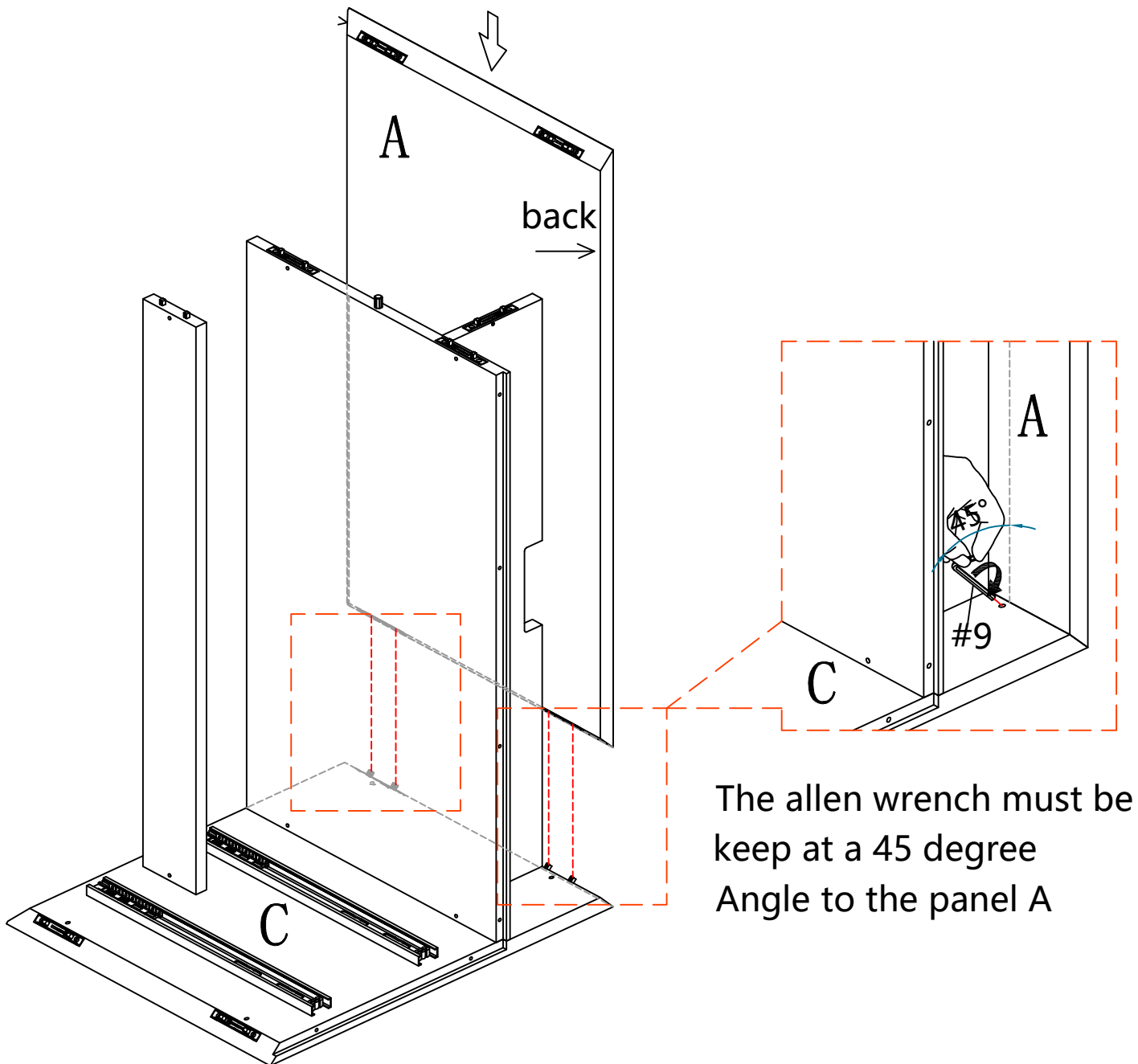

The allen wrench must be keep at a 45 degree Angle to the panel A

#9	x1
	
M4	

08/20



# ASSEMBLY INSTRUCTIONS

## STEP-4

1. Insert panel (B) into panel (C), make sure all holes aligned and then tighten it with allen key #9 as picture show.

The allen wrench must be keep at a 45 degree Angle to the panel B

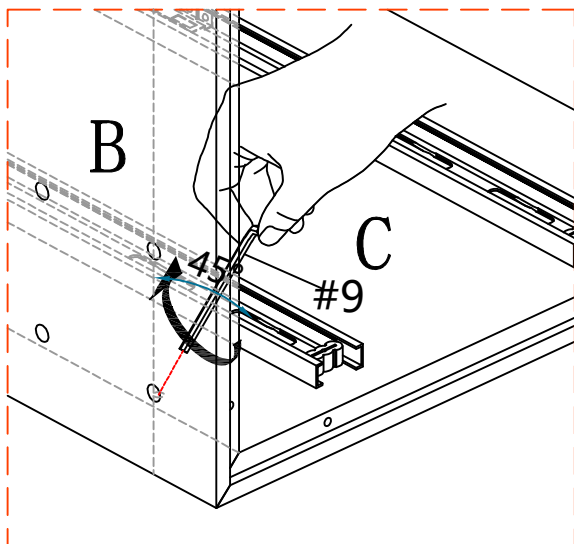
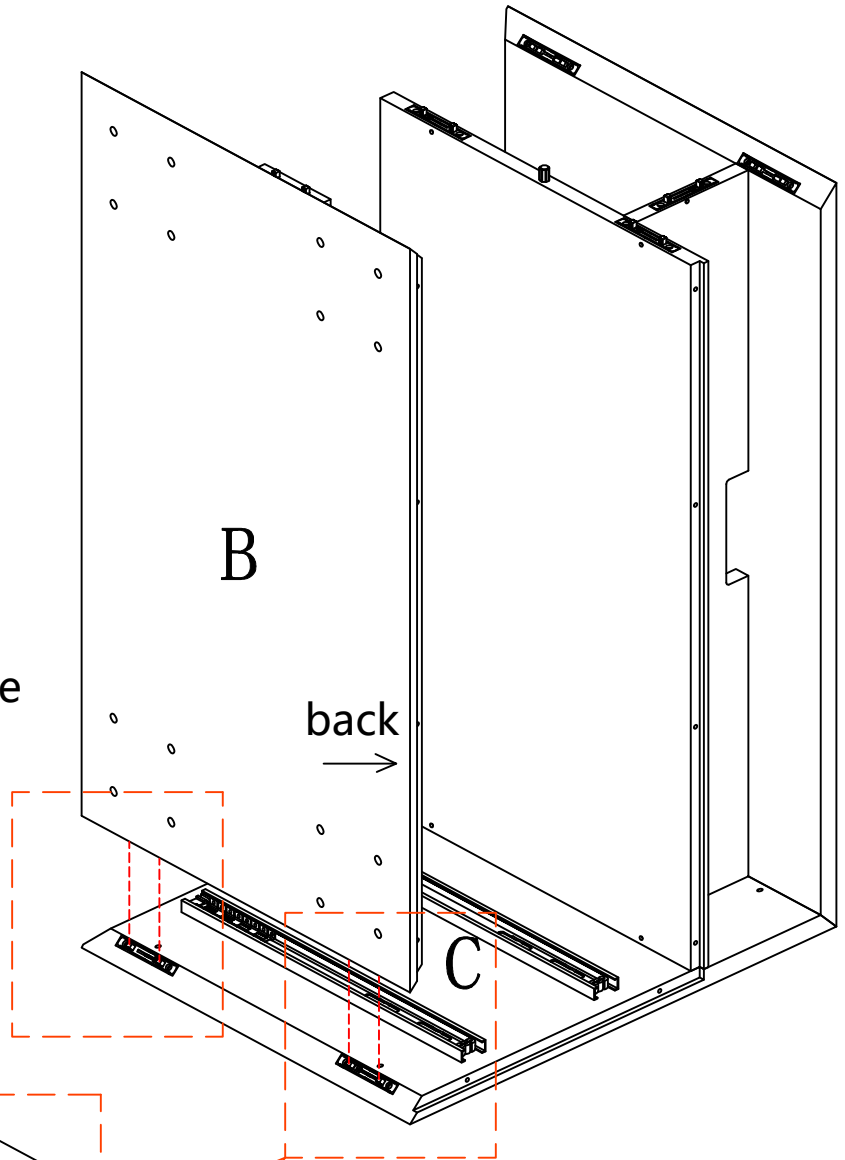

#9	x1
M4	

# ASSEMBLY INSTRUCTIONS

## STEP-5

1. Insert side panel (D) into the corresponding hole of preassembled step 4, make sure all holes aligned and use allen key #9 to tighten it as picture show.

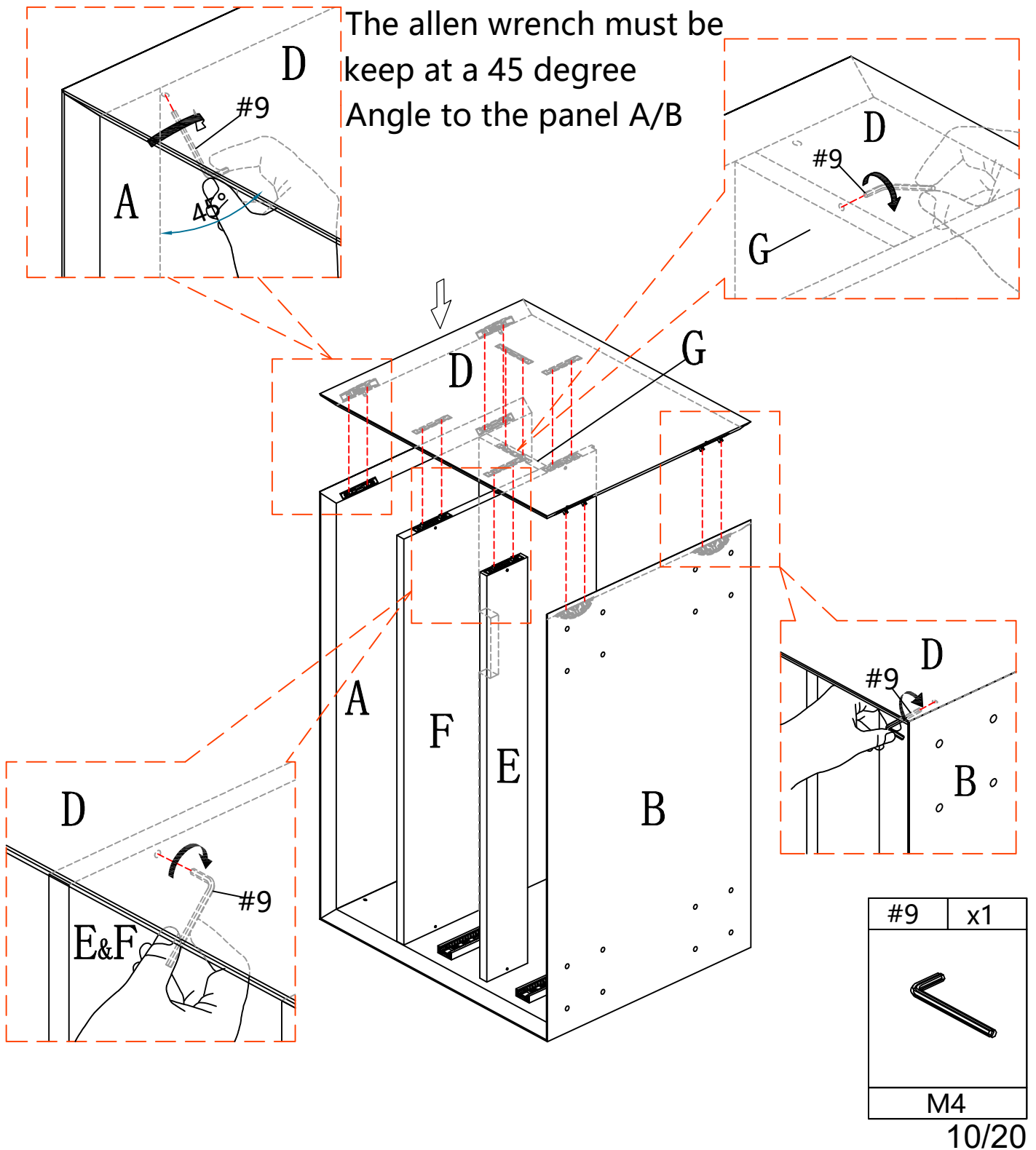

# ASSEMBLY INSTRUCTIONS

## STEP-6

1.insert back panel(I) into the groove of preassembled step 5,make sure all holes aligned and use screw#1 to attach them , tighten screw #1 with screwdriver#10.

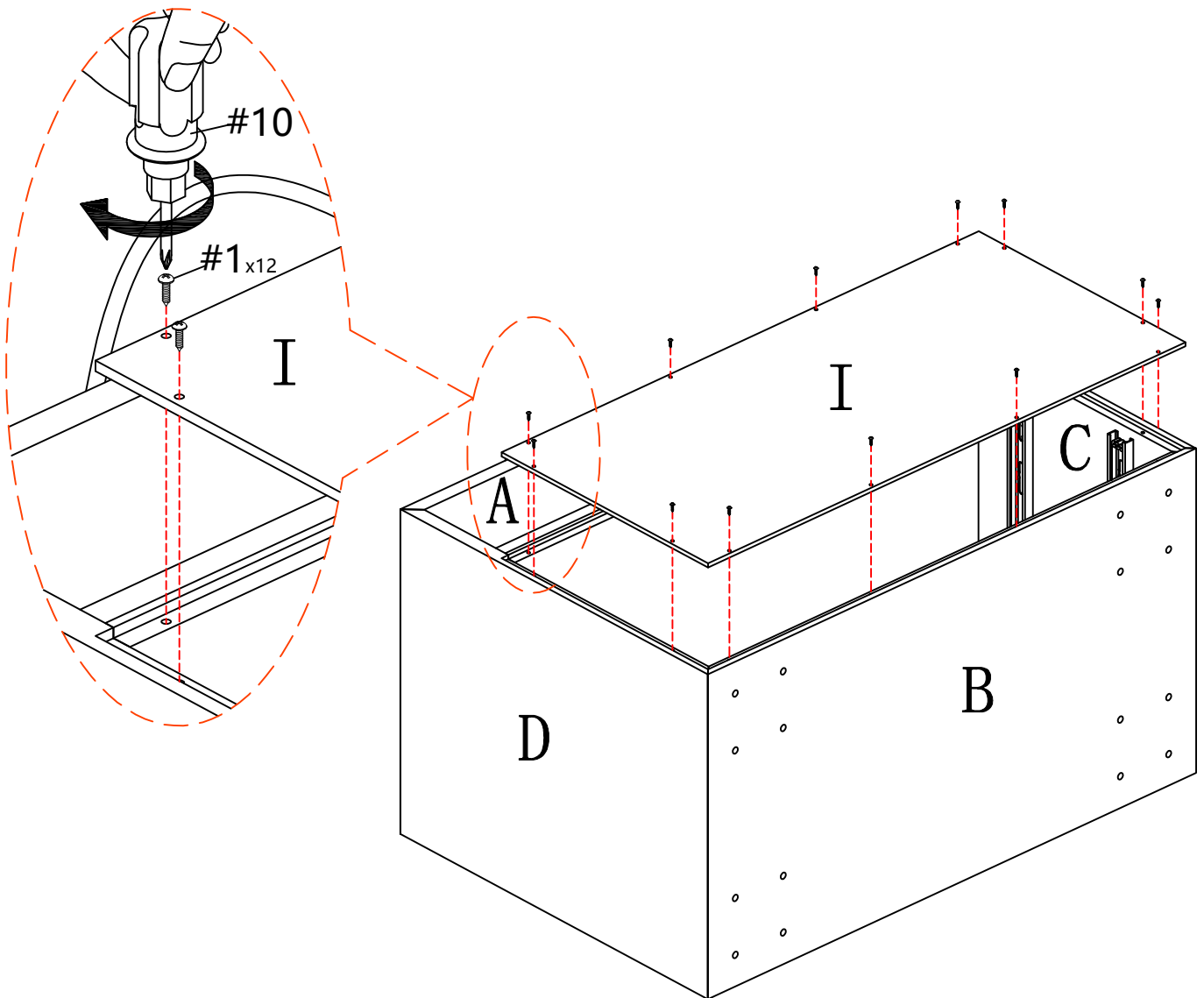

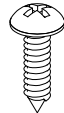
#1	x12
	
ø3*14mm	

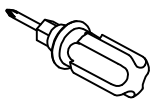



#10	x1
	

# ASSEMBLY INSTRUCTIONS

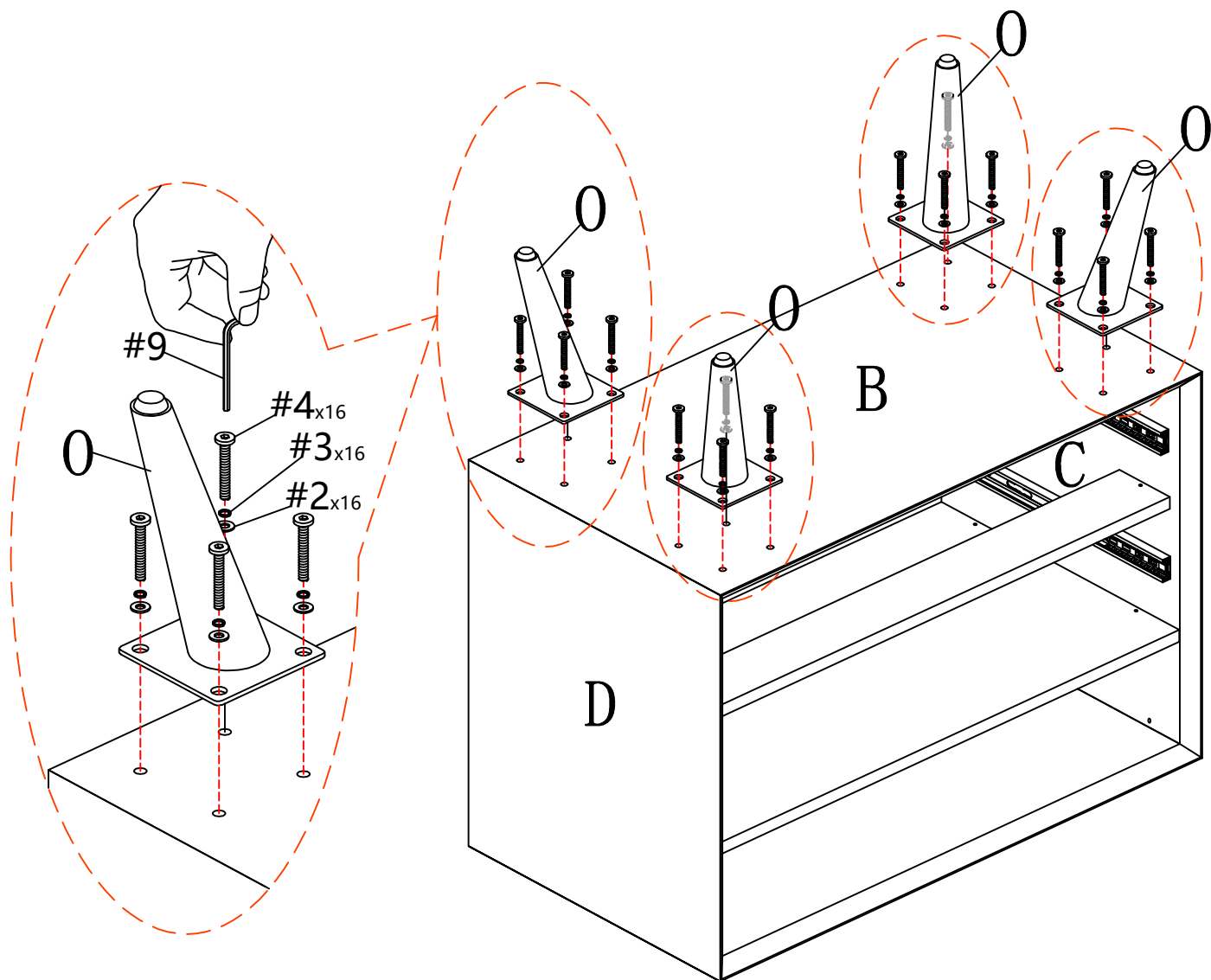
## STEP-7

1. Insert gasket #3 and #2 in sequence into bolt #4, install leg O on of bottom panel B, ensure the corresponding holes are aligned and fix with screw #4, then tighten the screw with an Allen key #9.

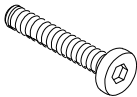

#2	x16	#3	x16	#4	x16	#9	x1
							
$\phi 1/4"$		$\phi 1/4"$		$\phi 1/4" * 1/2"$		M4	

# ASSEMBLY INSTRUCTIONS

## STEP-8

1.insert part (H) into the preassembled step 7,make sure all holes aligned and use screw#5 to attach them , tighten screw #5 with screwdriver#10.

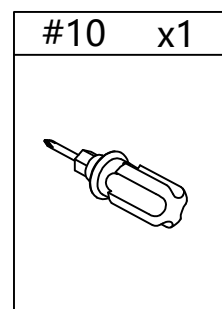
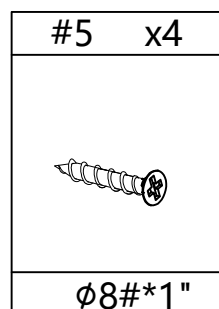
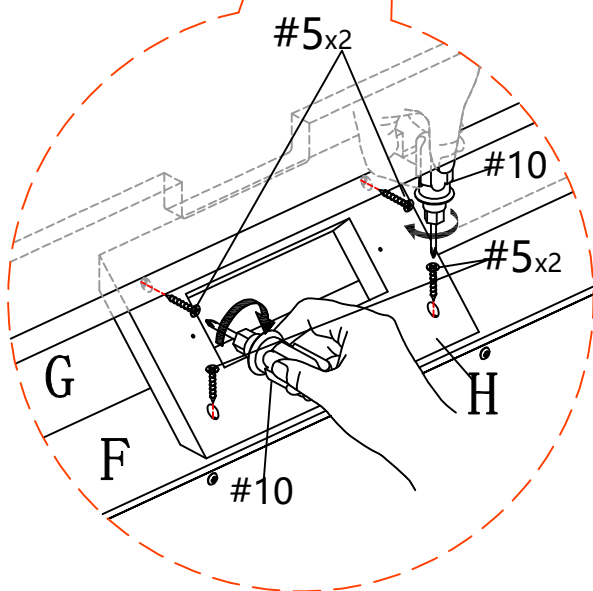
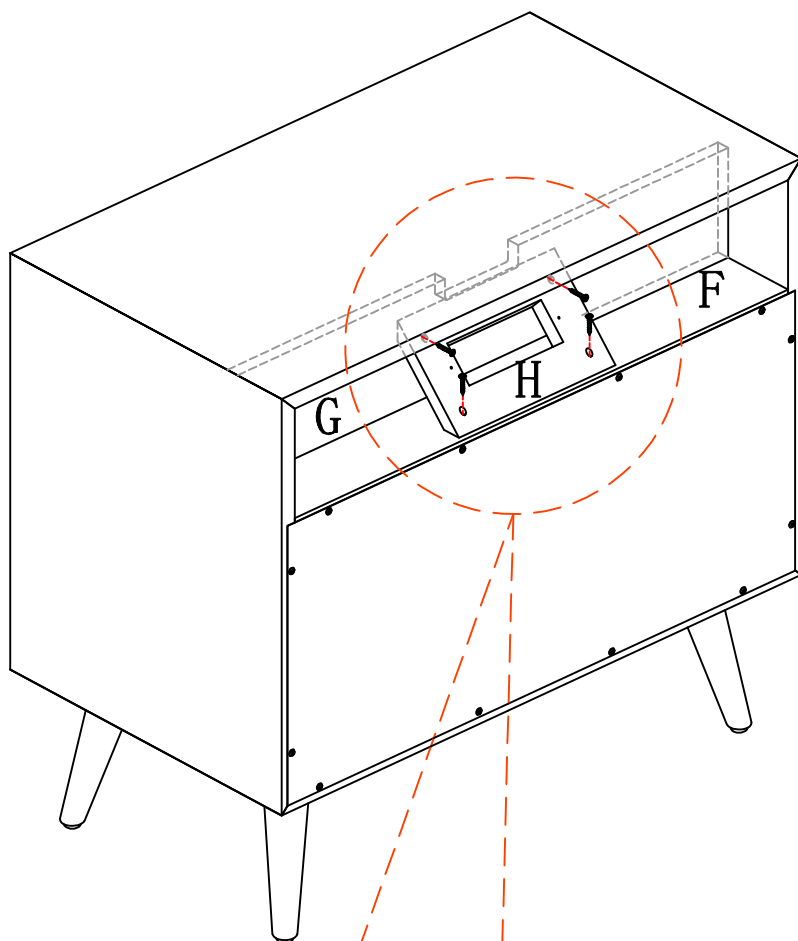

# ASSEMBLY INSTRUCTIONS

## STEP-9

1.insert part #8 into the preassembled step 8,make sure all holes aligned and use screw#6 to attach them , tighten screw #6 with screwdriver#10.

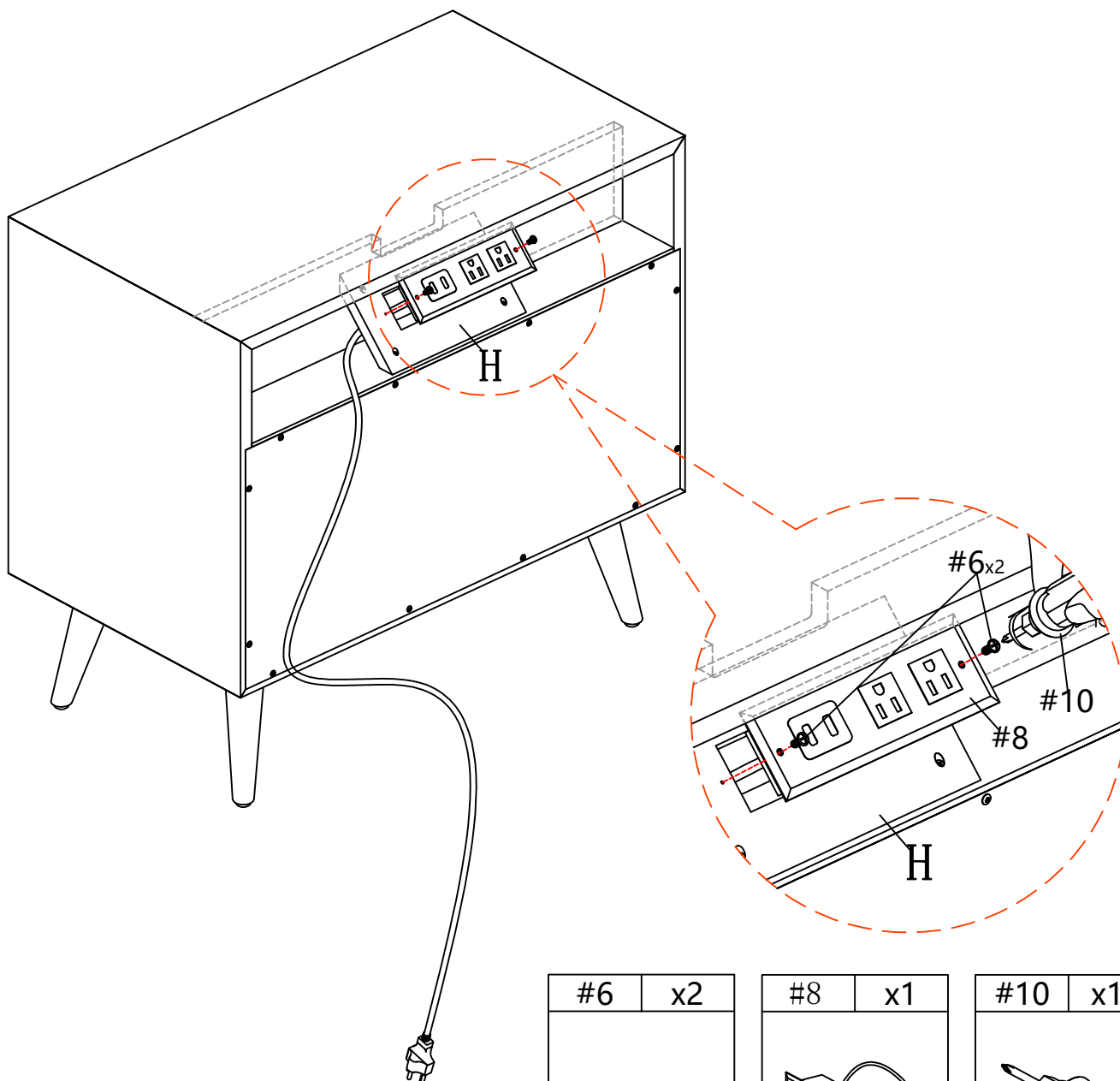

#6	x2
	
ø3*12mm	

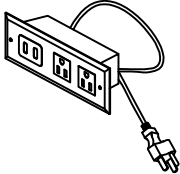
#8	x1
	

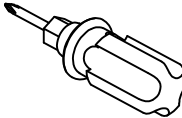
#10	x1
	

# ASSEMBLY INSTRUCTIONS

## STEP-10

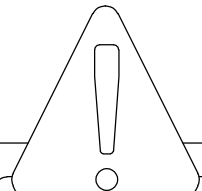
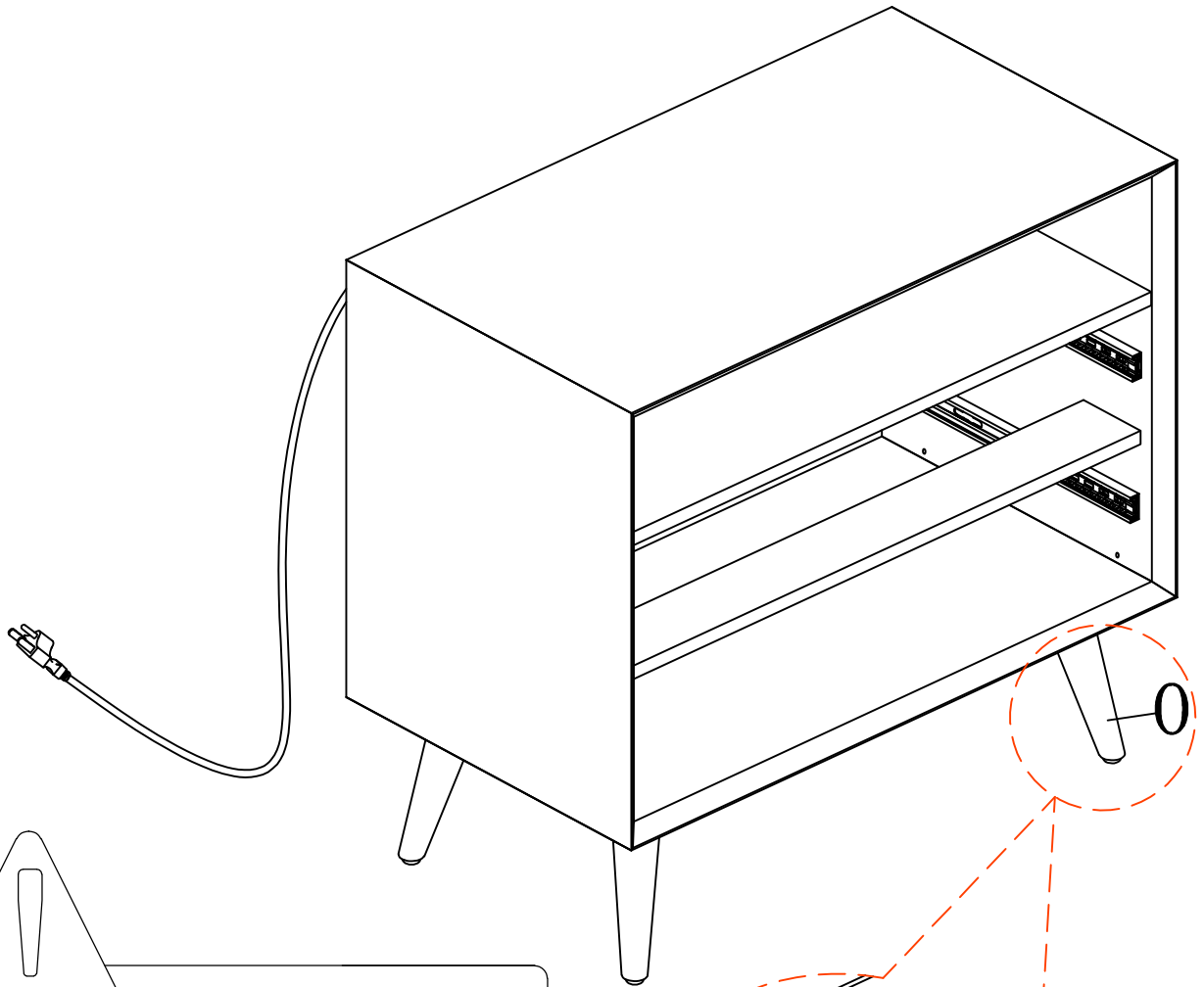

**Attention:**  
Before the next step, adjust the feet of the locker to keep it level.

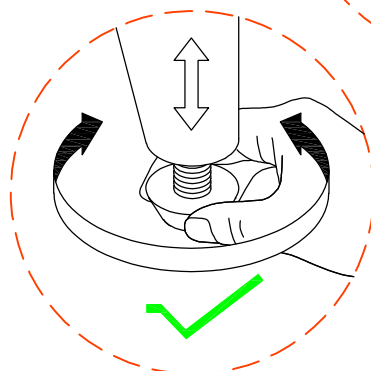
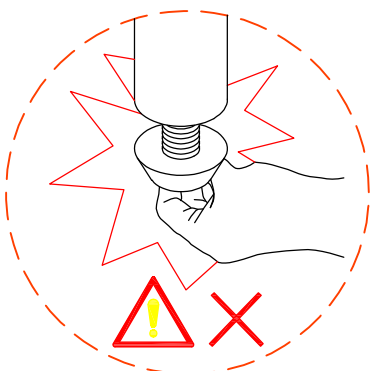
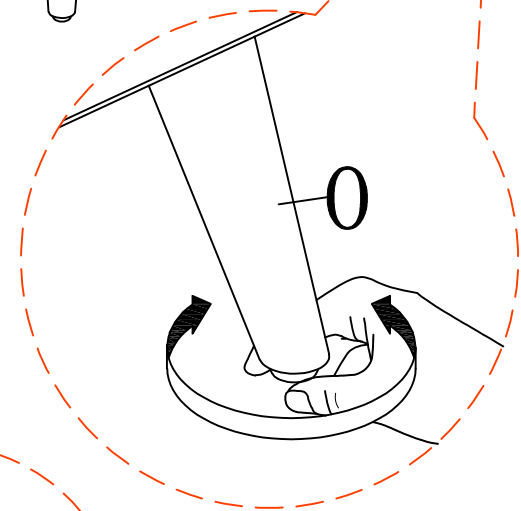

# ASSEMBLY INSTRUCTIONS

## STEP-11

1. Connect part (K&L) to part J using screw #7 and tighten it with screwdriver #10. Slide in the part (M) into the groove in part (L&K). make sure they are also in groove in part (J).

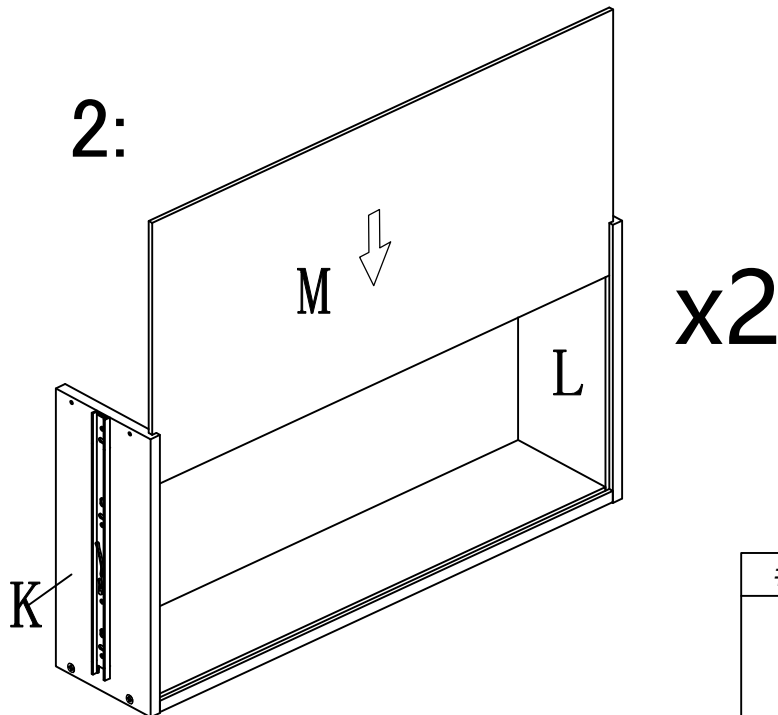
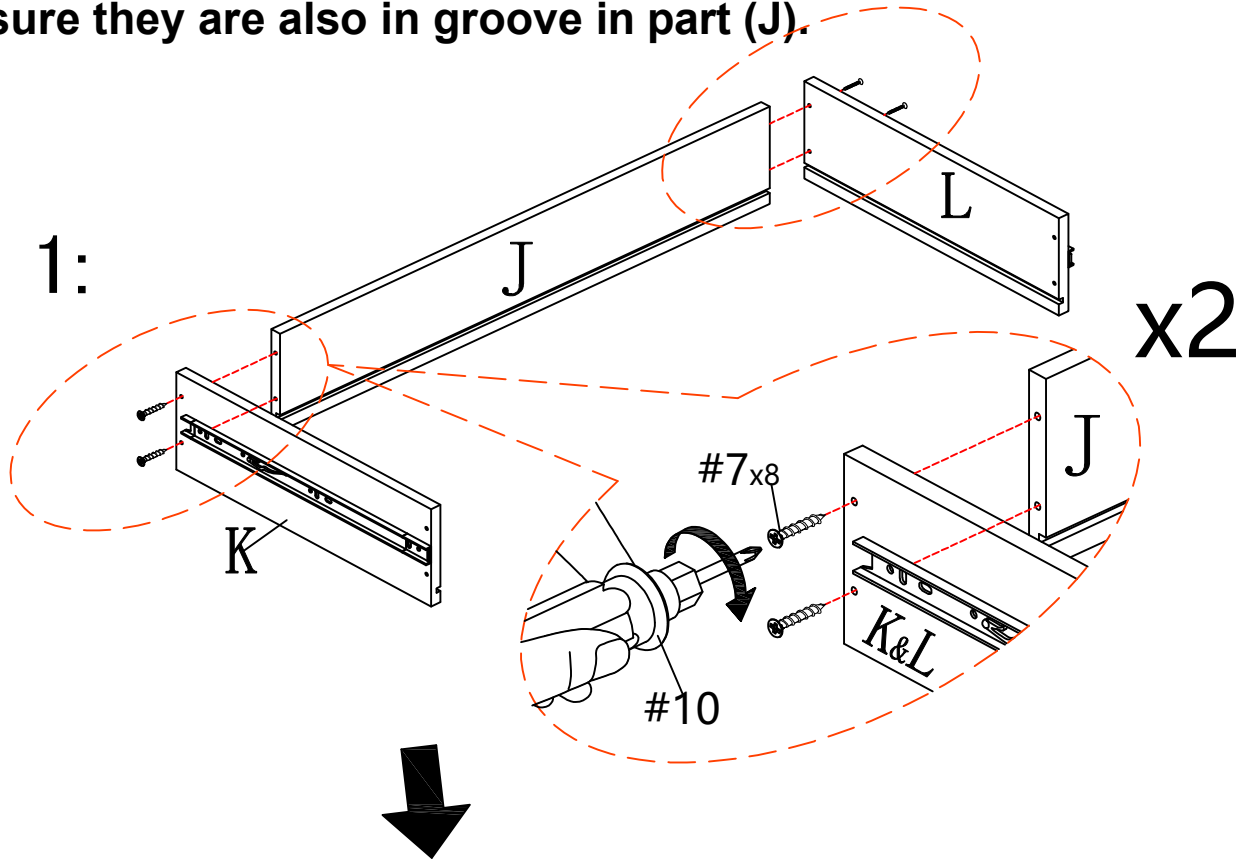

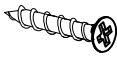
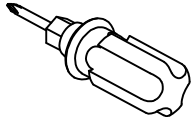
#7	x8	#10	x1
			
ø8#*1"			



# ASSEMBLY INSTRUCTIONS

## STEP-12

1. Connect part (K&L) to part N using screw #7 and tighten it with screwdriver #10.

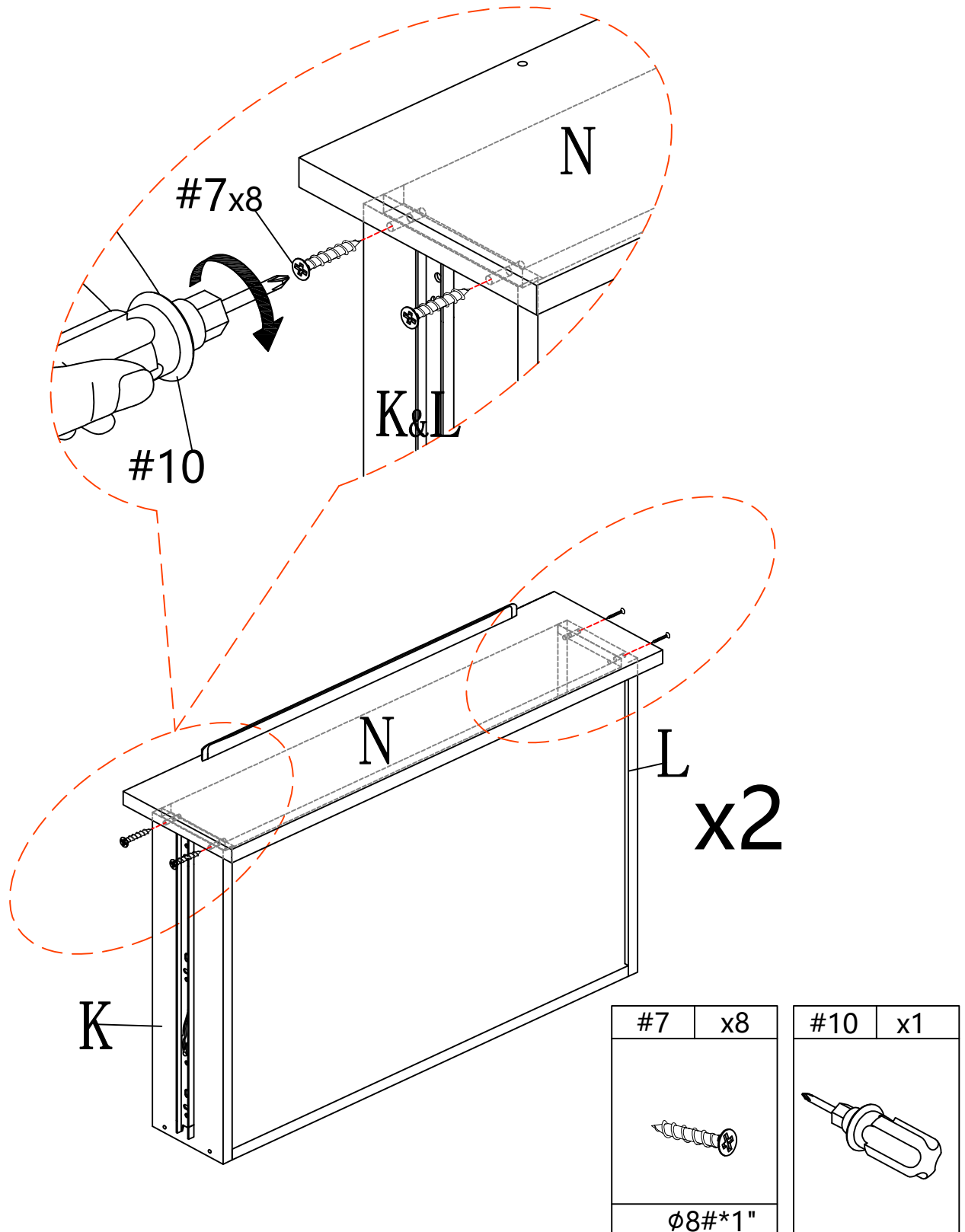

# ASSEMBLY INSTRUCTIONS

## STEP-13

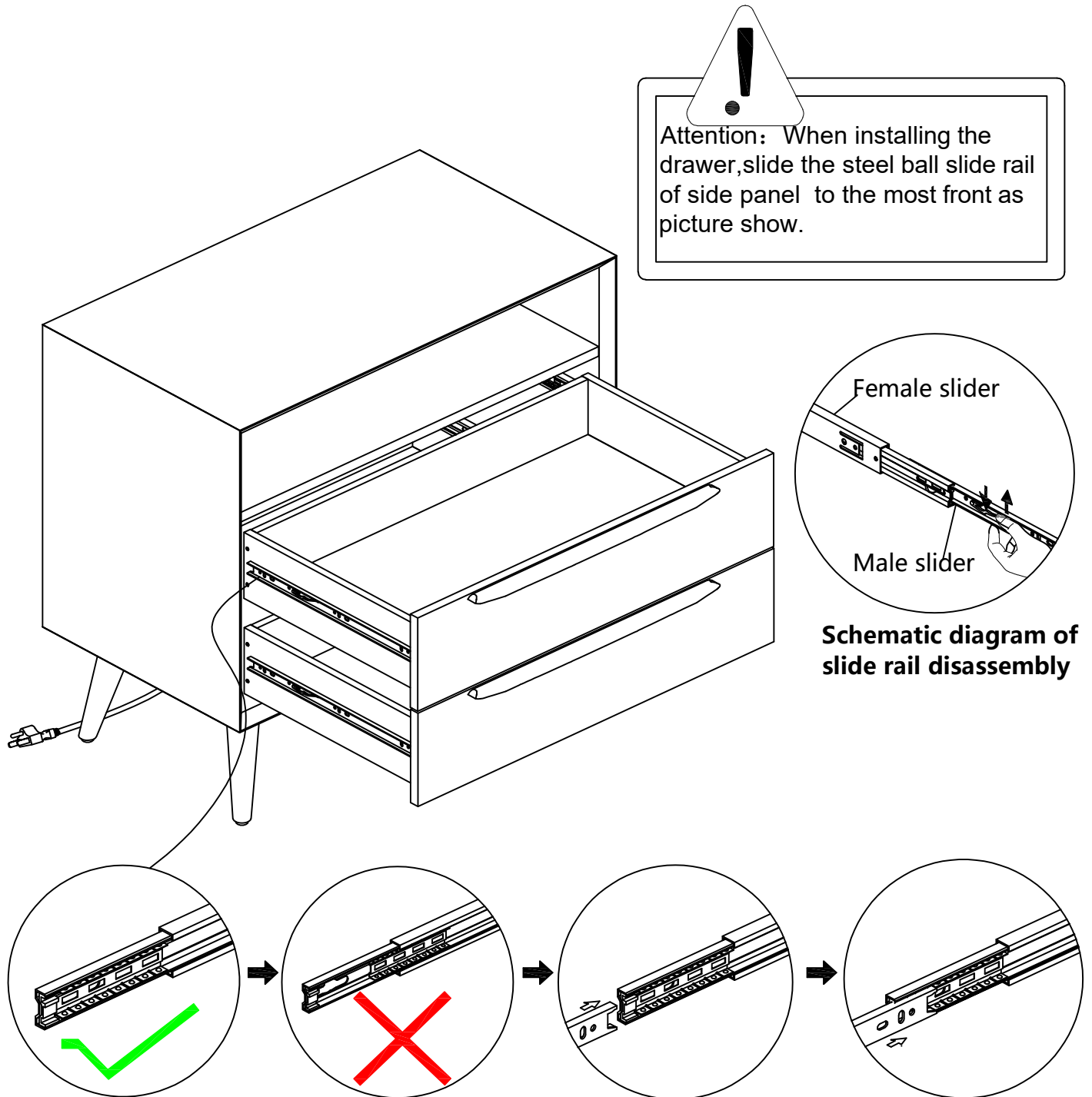

# ASSEMBLY INSTRUCTIONS

## STEP-14

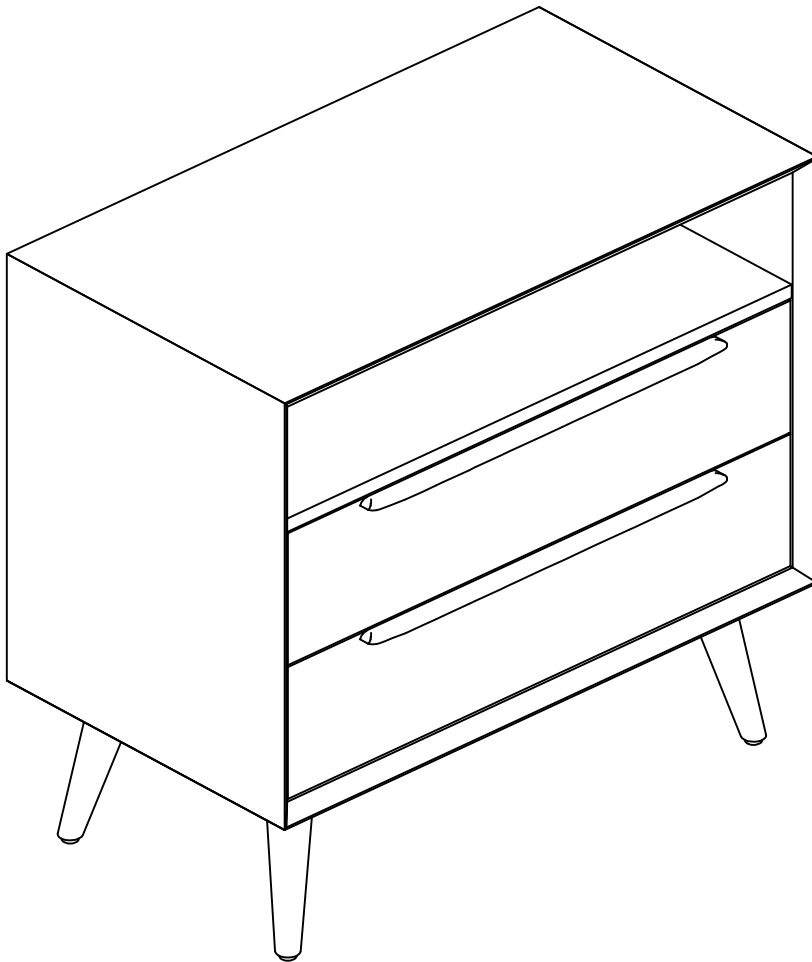

**Assembly completed.**

# WARRANTY

1. We strive to offer high-quality products, and we also try our best to satisfy each and every customer that orders from us with product or service as needed.
2. We provide 30 days warranty starting from the time you receive the item. Each customer must provide a record of their order such as the order number, or item receipt for any items that are out of the warranty period you may also still receive.
3. Replacement parts by purchasing them with our company if they are available.

Are you having difficulty  
With assembly? Missing parts?  
Please send email with your order No to  
[customerservice@hulalahome.com](mailto:customerservice@hulalahome.com)  
For return, please check the return policy with  
the retailer or market place you bought from.

Appreciate your purchasing from us.  
Pop up your life by our furniture piece!