

HULALA

H O M E

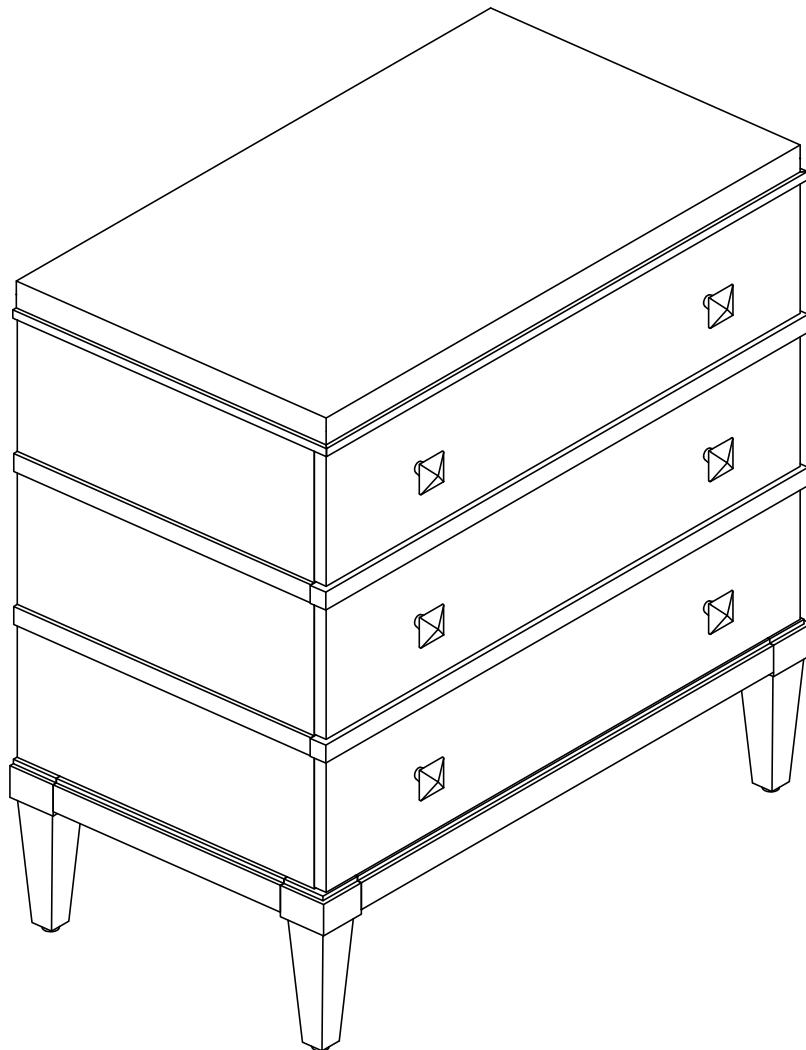

ITEM NO.NSLS1236

NOTE:

This brochure contains IMPORTANT safty info. Please read and keep for future reference.

MAINTAINANCE AND WARNING

- 1.Keep furniture away from heat sources.
- 2.Do not clean furniture with harsh cleaner or polishes.Do not use detergents,solvents,abrasives,spray packs or leather cleaner. Use non-color mild soa with warm water to clean spills(Mix 1:10 soap to water).
- 3.Do not place furniture under direct sunlight,material will possibly fade over time.
- 4.Do not use on site dry cleaning machine.Children should not climb or jump on the furniture.
- 5.Do not write on furniture that is not protectedby a padded barrier.
- 6.Not for commercial use,only for residential use.

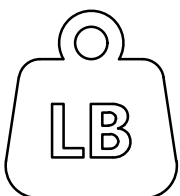

Weight Limitation
80 LBS

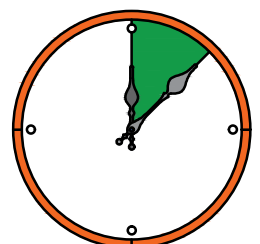

Around 45 min

EXPLOSIVE VIEW

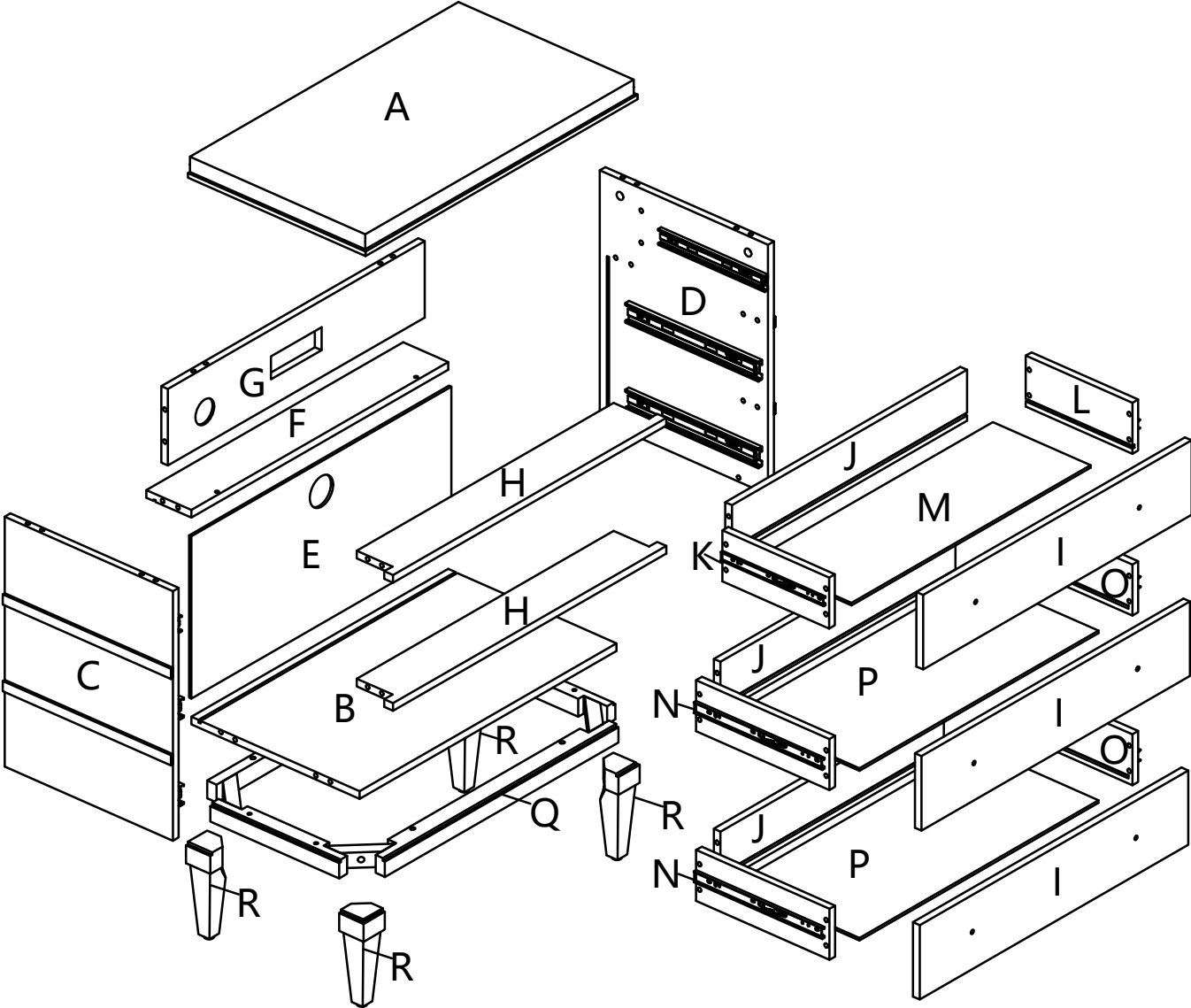

OVERVIEW



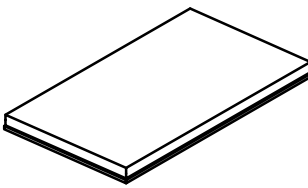
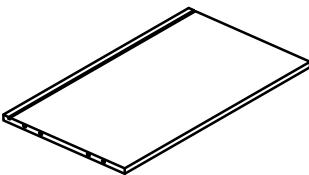
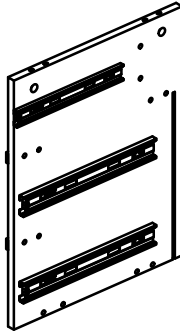
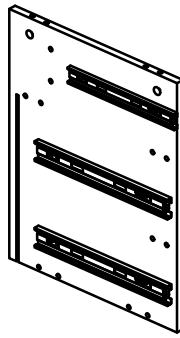
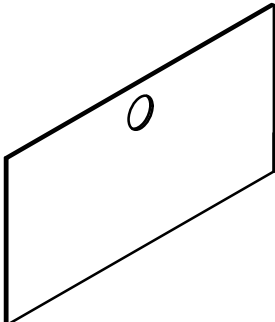
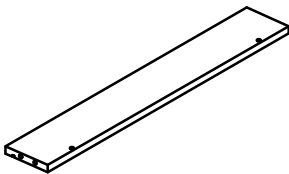
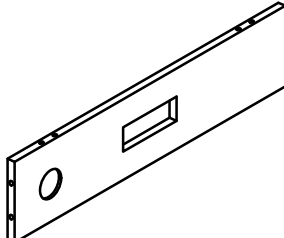
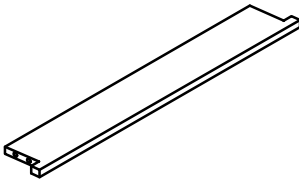
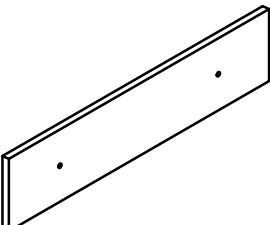
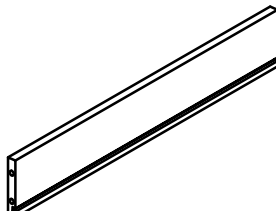
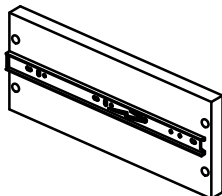
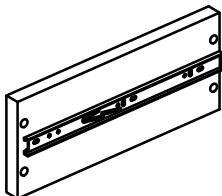
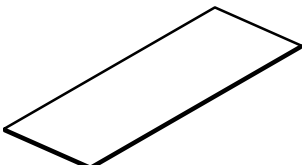
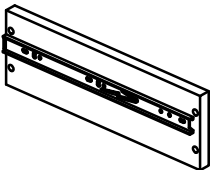
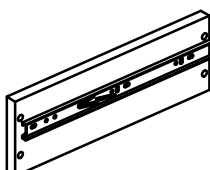
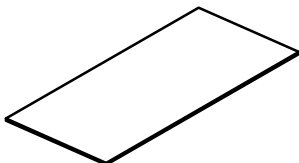



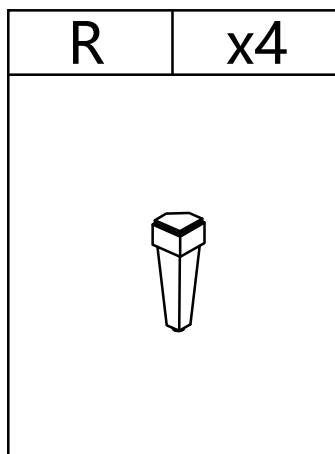
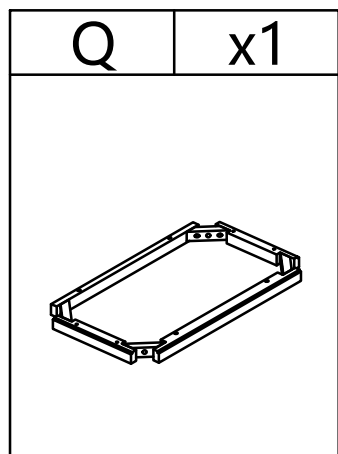



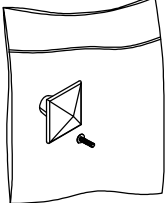

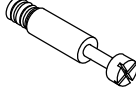
PARTS LIST 1

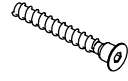
A	x1	B	x1	C	x1	D	x1
							
E	x1	F	x1	G	x1	H	x2
							
I	x3	J	x3	K	x1	L	x1
							
M	x1	N	x2	O	x2	P	x2
							



PARTS LIST 2

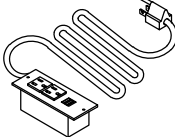
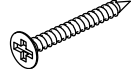
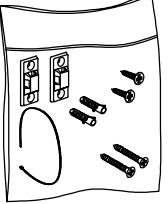
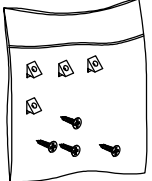





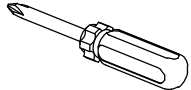



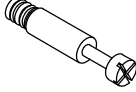

HARDWARE LIST

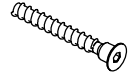
#1	x6	#2	x24	#3	x14	#4	x14	#5	x6	#6	x4
											
		8*30MM				Ø15*12.5MM		M6*50MM		M6*30mm	
#7	x4	#8	x4	#9	x4	#10	x2	#11	x1	#12	x24
											
M8*50mm		M8		M8		#8*5/8				Ø8*1-1/2 "	
#13	x2	#14	x4	#15	x1	#16	x4				
											
						M6					

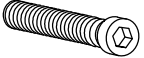
TOOL LIST

#17	x1	#18	x1	#19	x1
					
M8				M6	

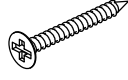
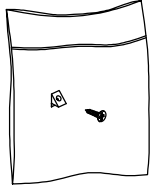
HARDWARE SPARE LIST



#2	x2	#3	x1	#4	x1	#5	x1	#6	x1	#7	x1
											
8*30MM				Ø15*12.5MM		M6*50MM		M6*30mm		M8*50mm	
#8	x1	#9	x1	#10	x1	#12	x2	#14	x1	#16	x1
											
				#8*5/8		Ø8*1-1/2 "				M6	

ASSEMBLY INSTRUCTIONS

STEP-1

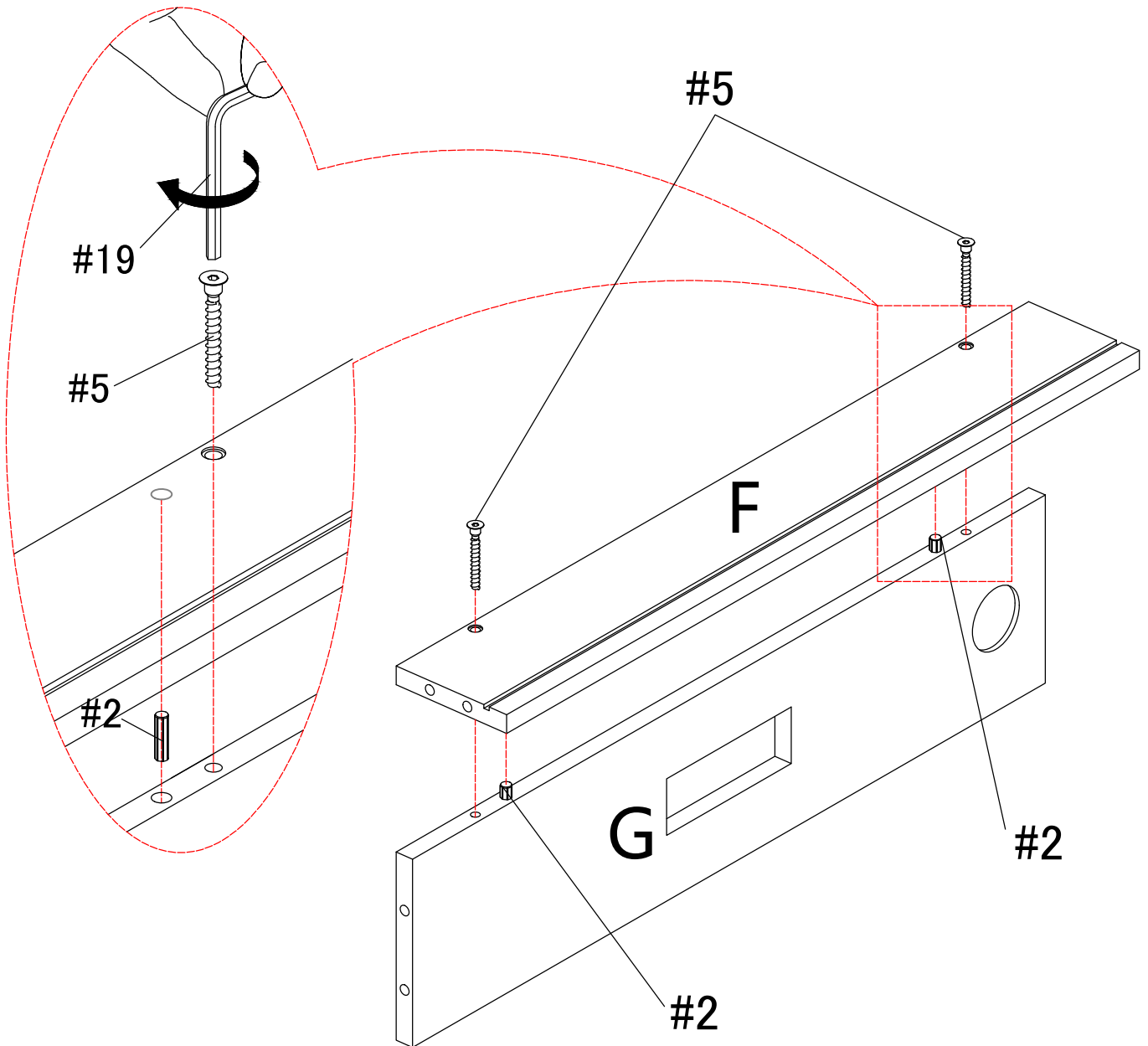
Align the holes in part (F) with the holes in part (G), insert wood dowel #2 by hand, and tighten screw #5 with an Allen wrench #19.

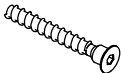



#2	x2	#5	x2	#19	x1
					
8*30MM		M6x50MM		M6	

ASSEMBLY INSTRUCTIONS

STEP-2

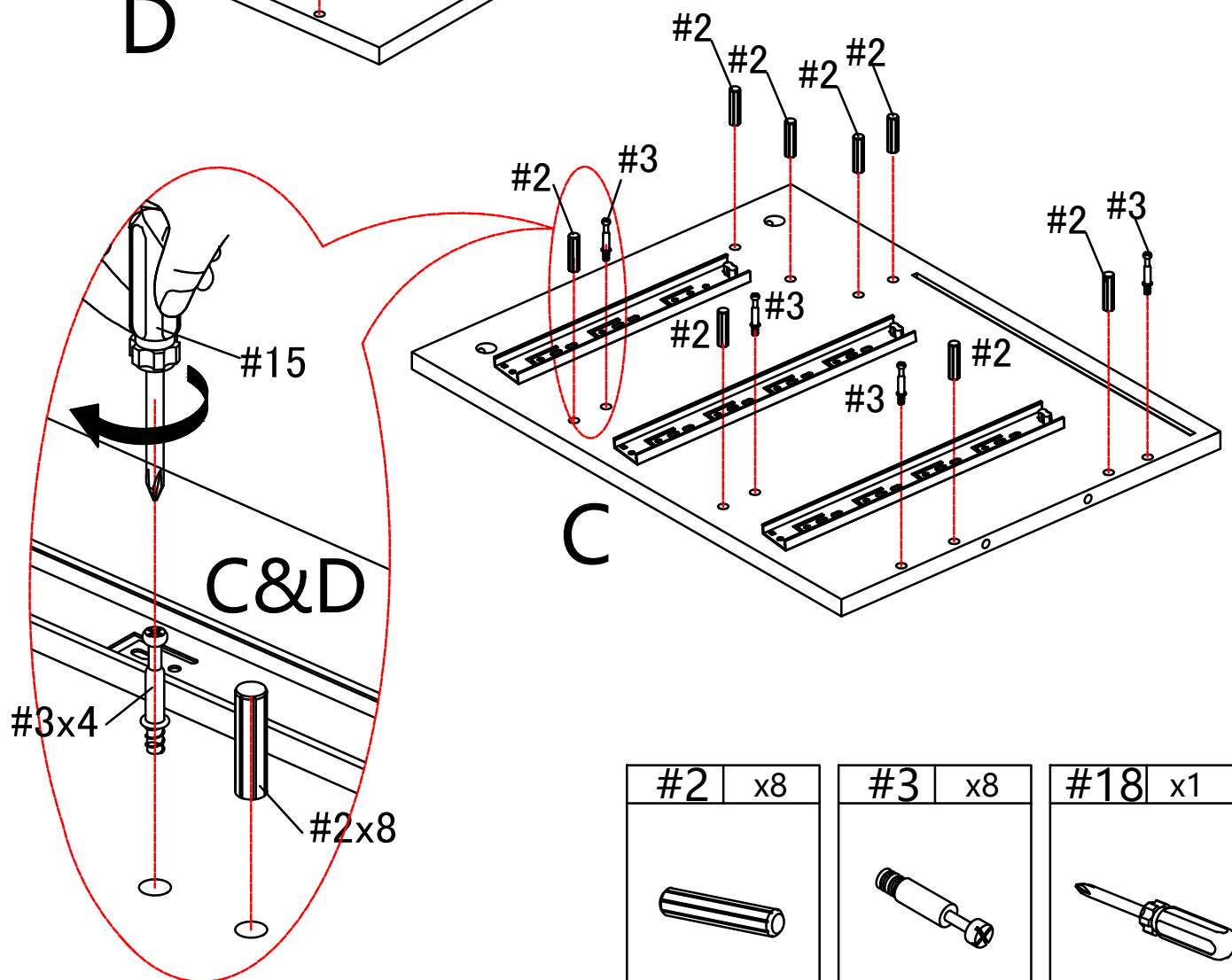
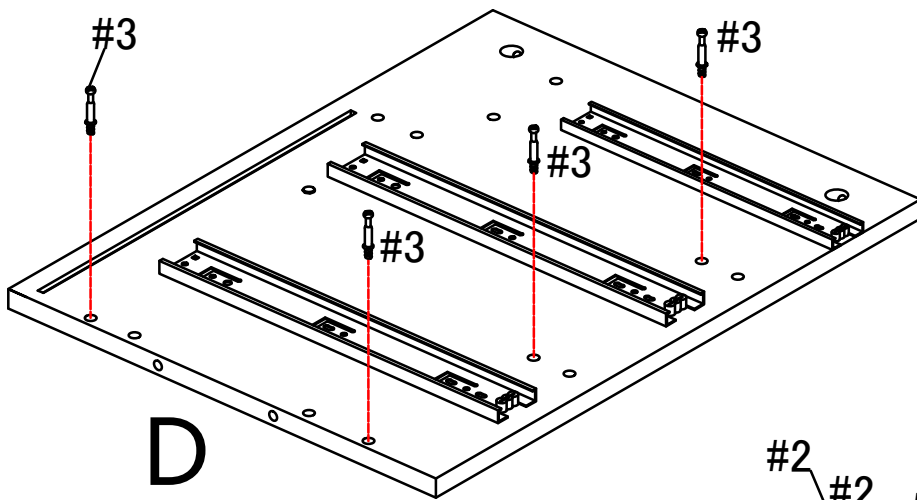
Insert wood dowel #2 by hand, insert bolt #3 into the corresponding hole in the side plate (C&D), and tighten bolt #3 with a #18 screwdriver.

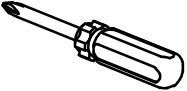

#2	x8	#3	x8	#18	x1
					
8*30MM					

ASSEMBLY INSTRUCTIONS

STEP-3

Insert the panels (G&F) into the side panels (C),make sure all holes aligned .

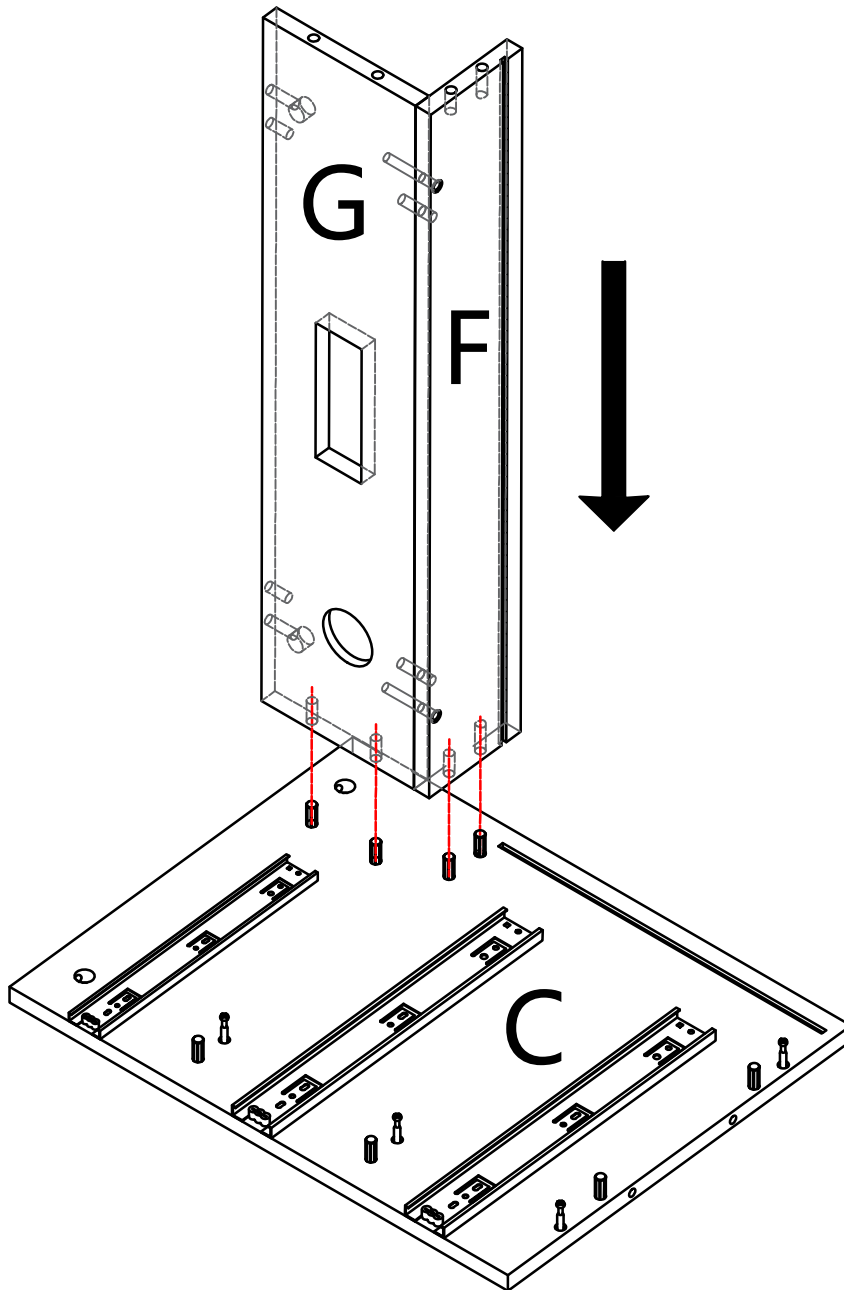



ASSEMBLY INSTRUCTIONS

STEP-4

Insert the panels (H) into the side panels (C), make sure all holes aligned and insert cam bolt #4 into the corresponding hole of panel (H), tighten cam bolt #4 with screwdriver #18.

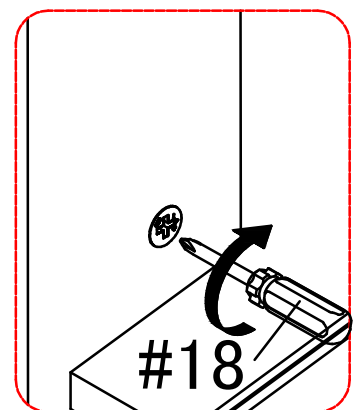
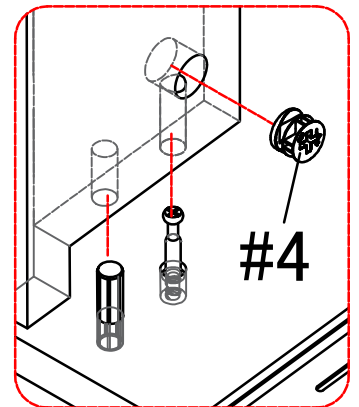
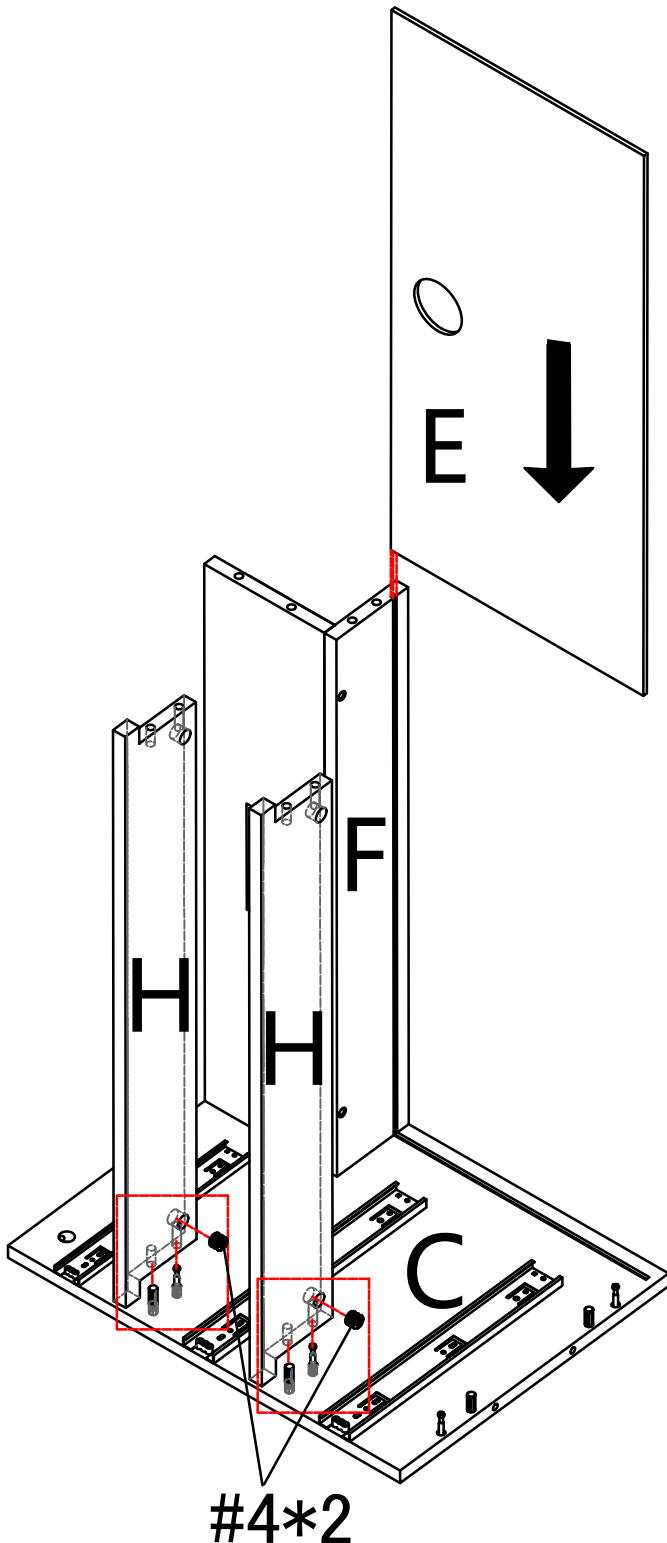
Slide in the part (E) into the groove in part (C). make sure they are also in groove in part (F).



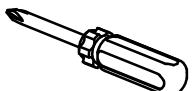

#4	x2	#18	x1
			
Ø15*12.5MM			

ASSEMBLY INSTRUCTIONS

STEP-5

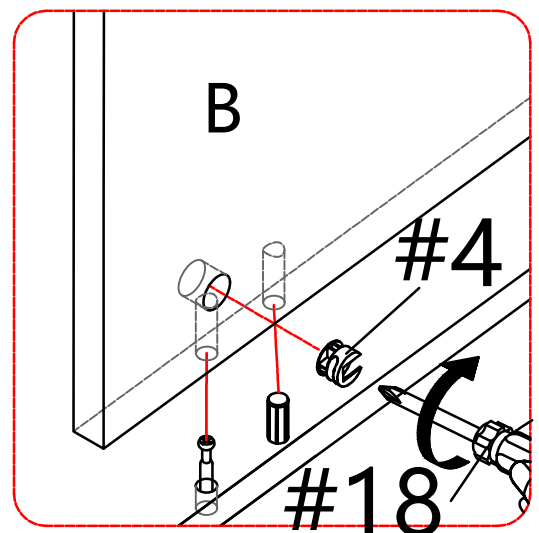
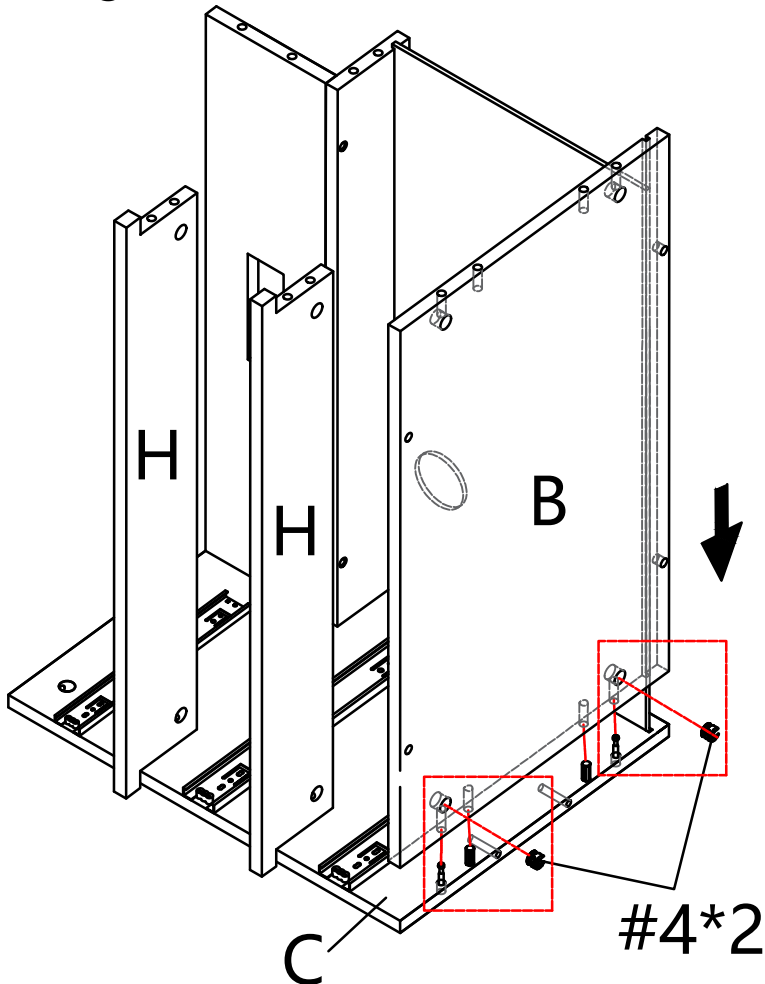
Insert the panels (B) into the side panels (C&E), make sure all holes aligned and insert cam bolt #4 into the corresponding hole of panel (B), tighten cam bolt #4 with screwdriver #18.



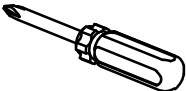

#4	x2	#18	x1
			
Ø15*12.5MM			

ASSEMBLY INSTRUCTIONS

STEP-6

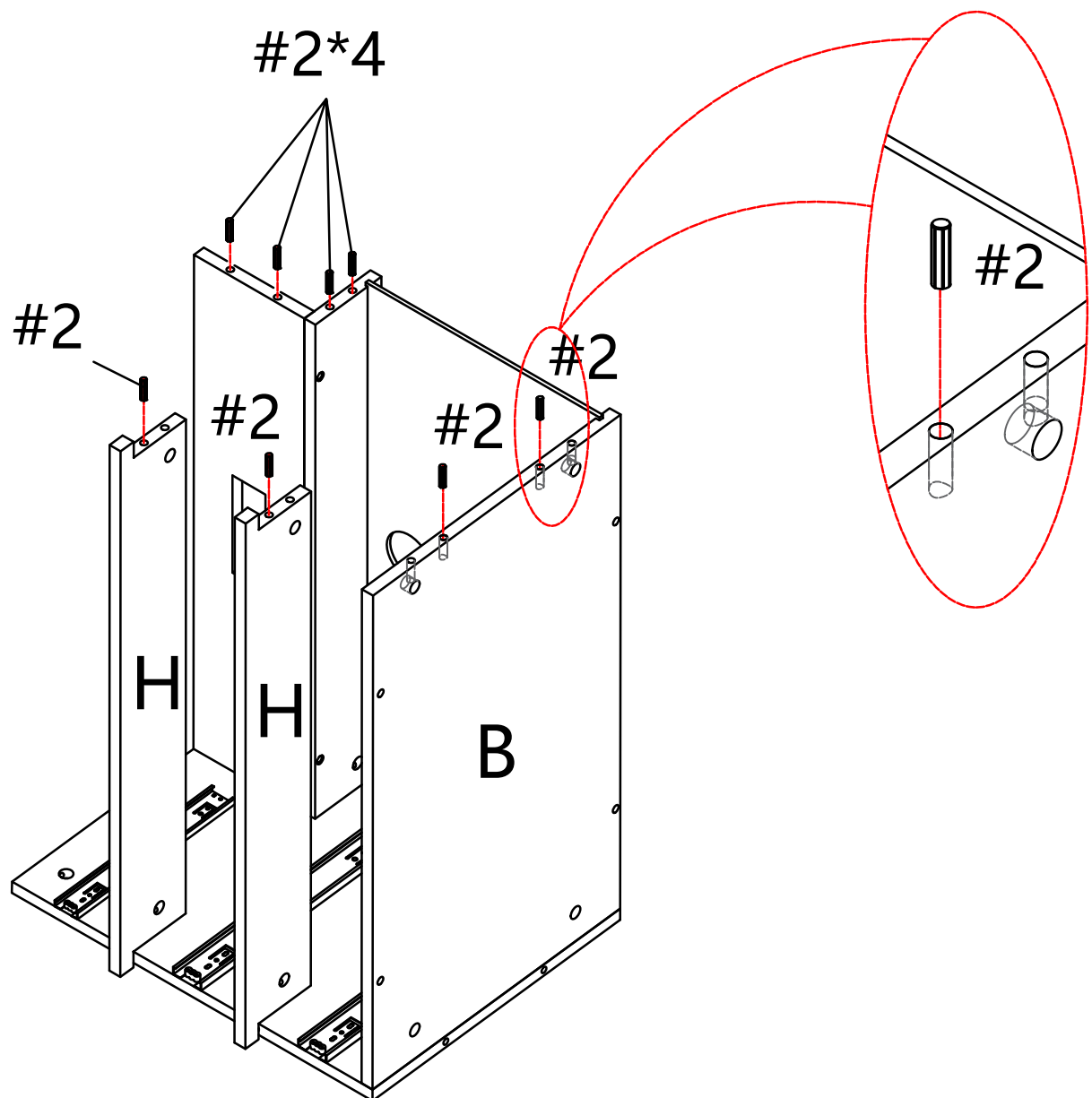
1. insert wood dowel #2 by hand into the corresponding hole in the panel (B&E&H&G)





#2	x8
	
8*30MM	

ASSEMBLY INSTRUCTIONS

STEP-7

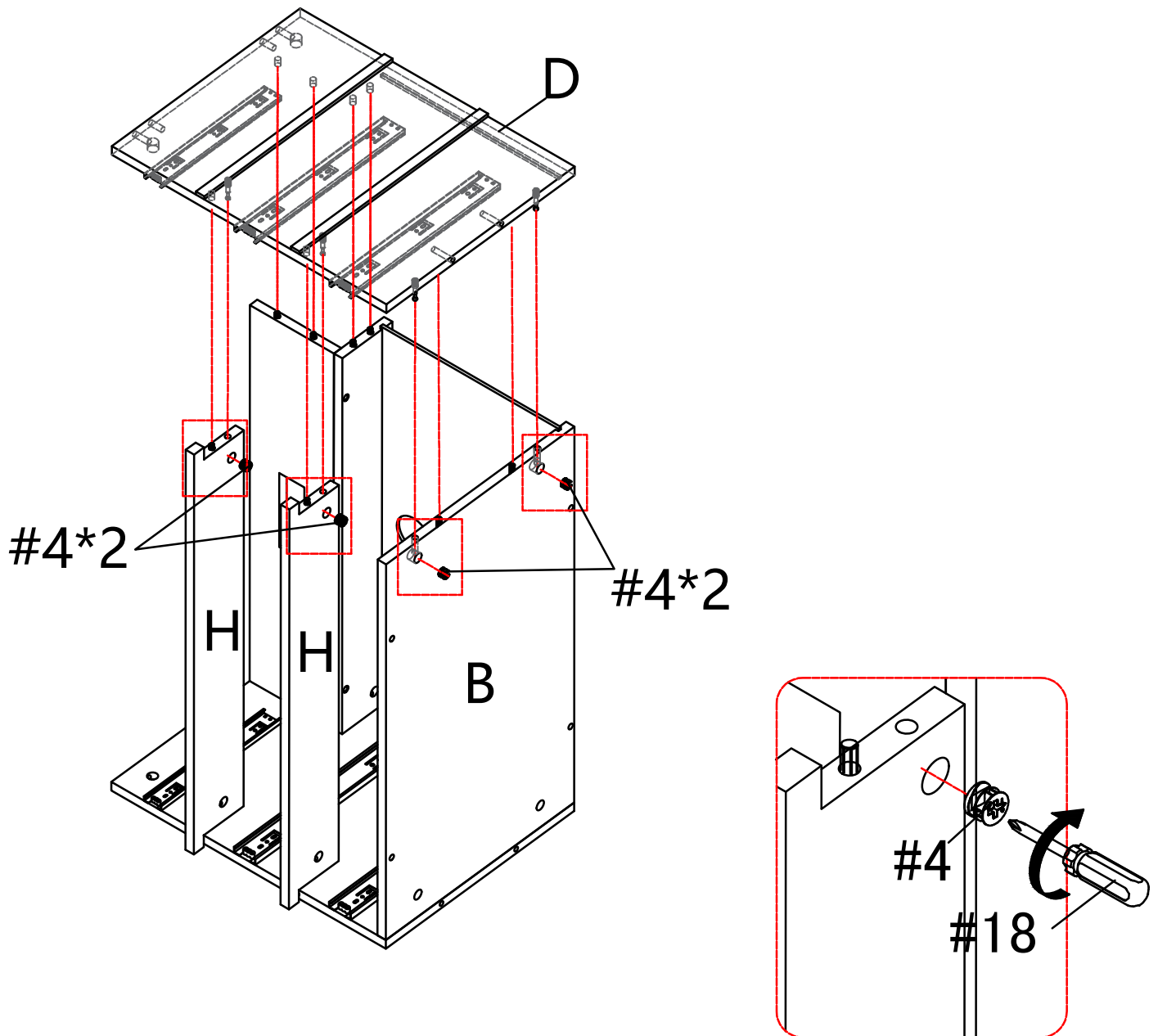
1. Attach part D to the unit preassembled in step 6. Aligning the holes on the components.
2. Insert cam bolt #4 into the corresponding hole in the panel (B&E&H). Then, use a No. 18 screwdriver to tighten cam bolt #4.

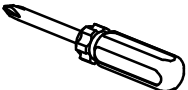

#4	x4	#18	x1
			
Ø15*12.5MM			

ASSEMBLY INSTRUCTIONS

STEP-8

1. Connect the leg frame to the cabinet. Align the hole in the leg frame part (Q) to the hole in the part (B&C&D), Insert gasket #16 into screw #5, tighten bolt #5 with allen key #19.
2. Connect the leg frame to the cabinet. Align the hole in the leg frame part (Q) to the hole in the part (B&C&D), tighten bolt #6 with allen key #19.

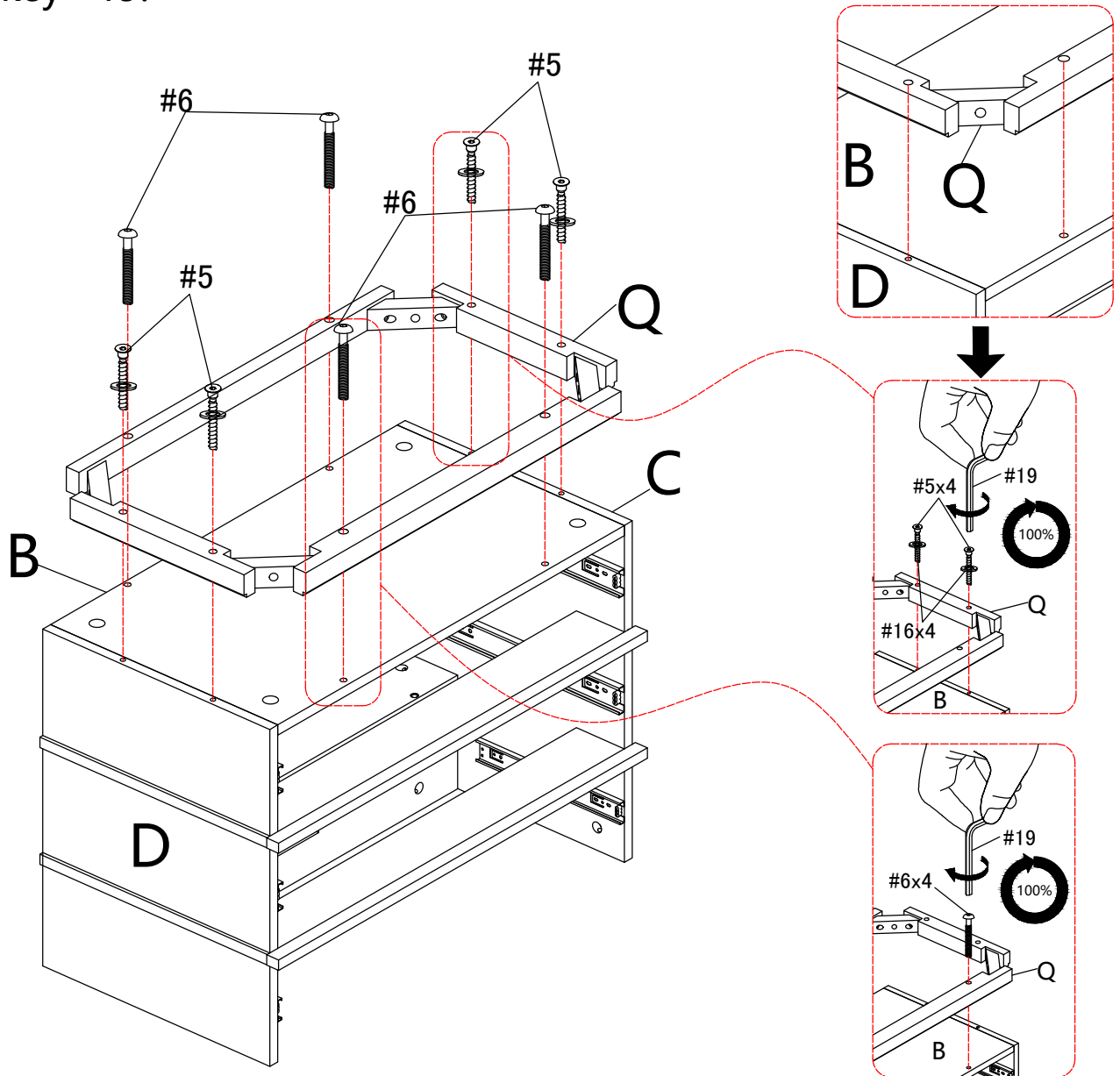





#5	x4	#6	x4	#16	x4	#19	x1
M6x50MM		M6x30mm		M6		M6	

ASSEMBLY INSTRUCTIONS

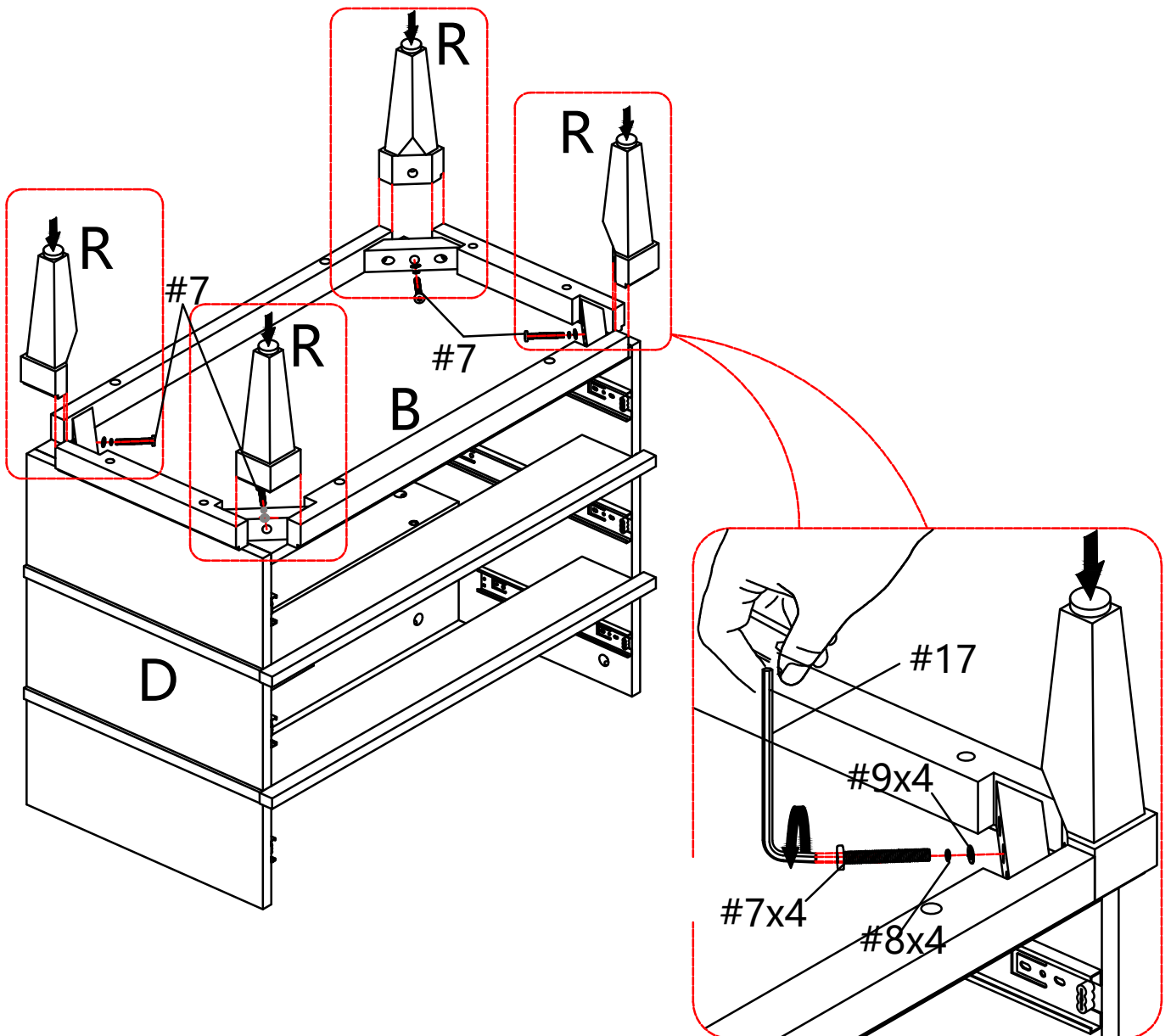
STEP-9

Insert gasket #8 and #9 in sequence into screw #7, install leg R on of bottom frame (Q), ensure the corresponding holes are aligned and fix with screw #7, then tighten the screw with an Allen key 17.





#8	x4	#9	x4	#7	x4	#17	x1
							
				M8x50mm		M8	

ASSEMBLY INSTRUCTIONS

STEP-10

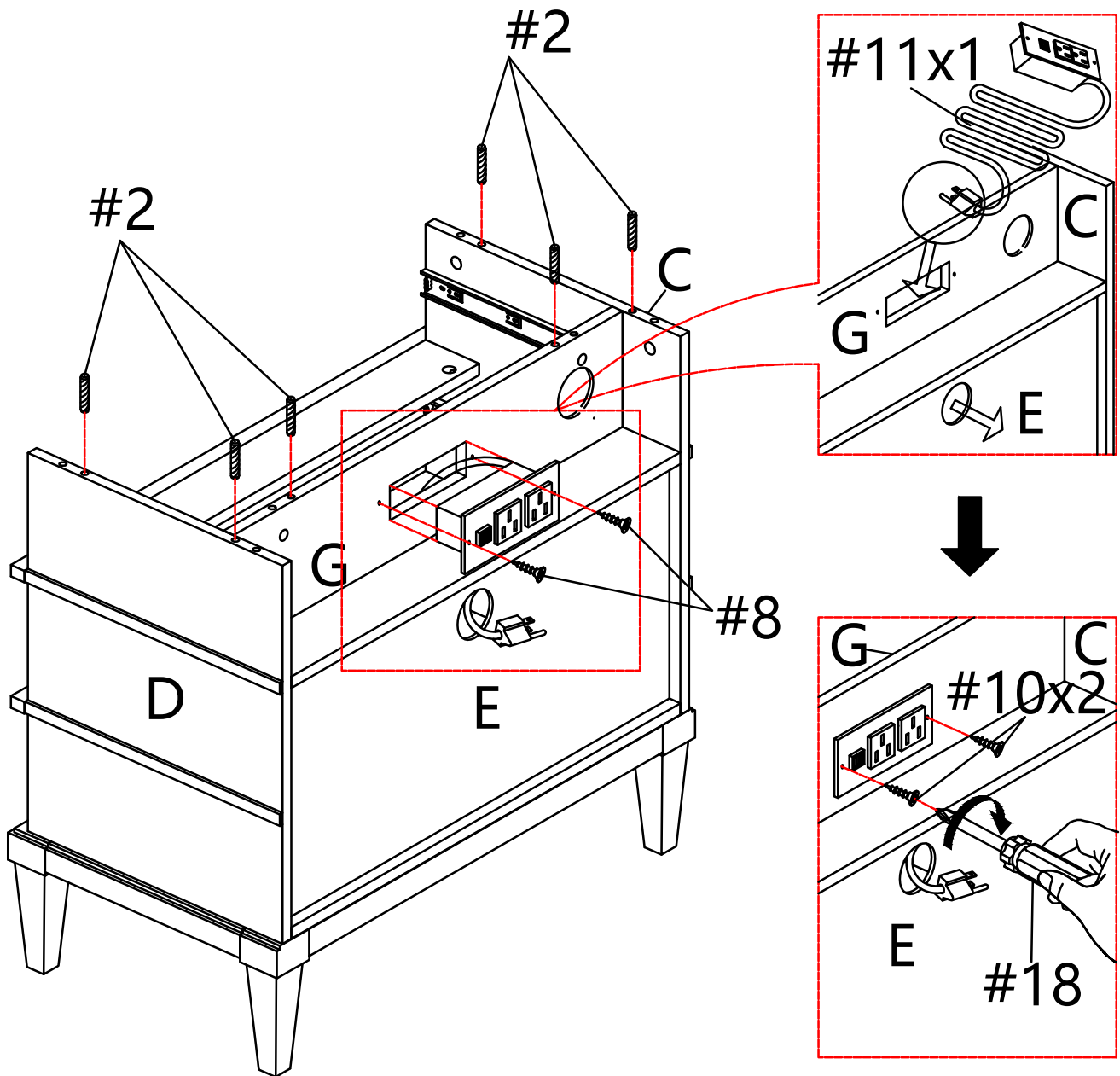
Insert wooden pin #2 to side panel (C&D&G) by hand. Connect socket #11 to part G using screw #10. and tighten it with screwdriver #18.

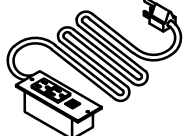
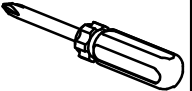

#2	x6	#10	x2	#11	x1	#18	x1
							
8*30MM		#8*5/8					

ASSEMBLY INSTRUCTIONS

STEP-11

Insert bolt #3 into the corresponding hole of top panel (A), tighten bolt #3 with screwdriver #18.

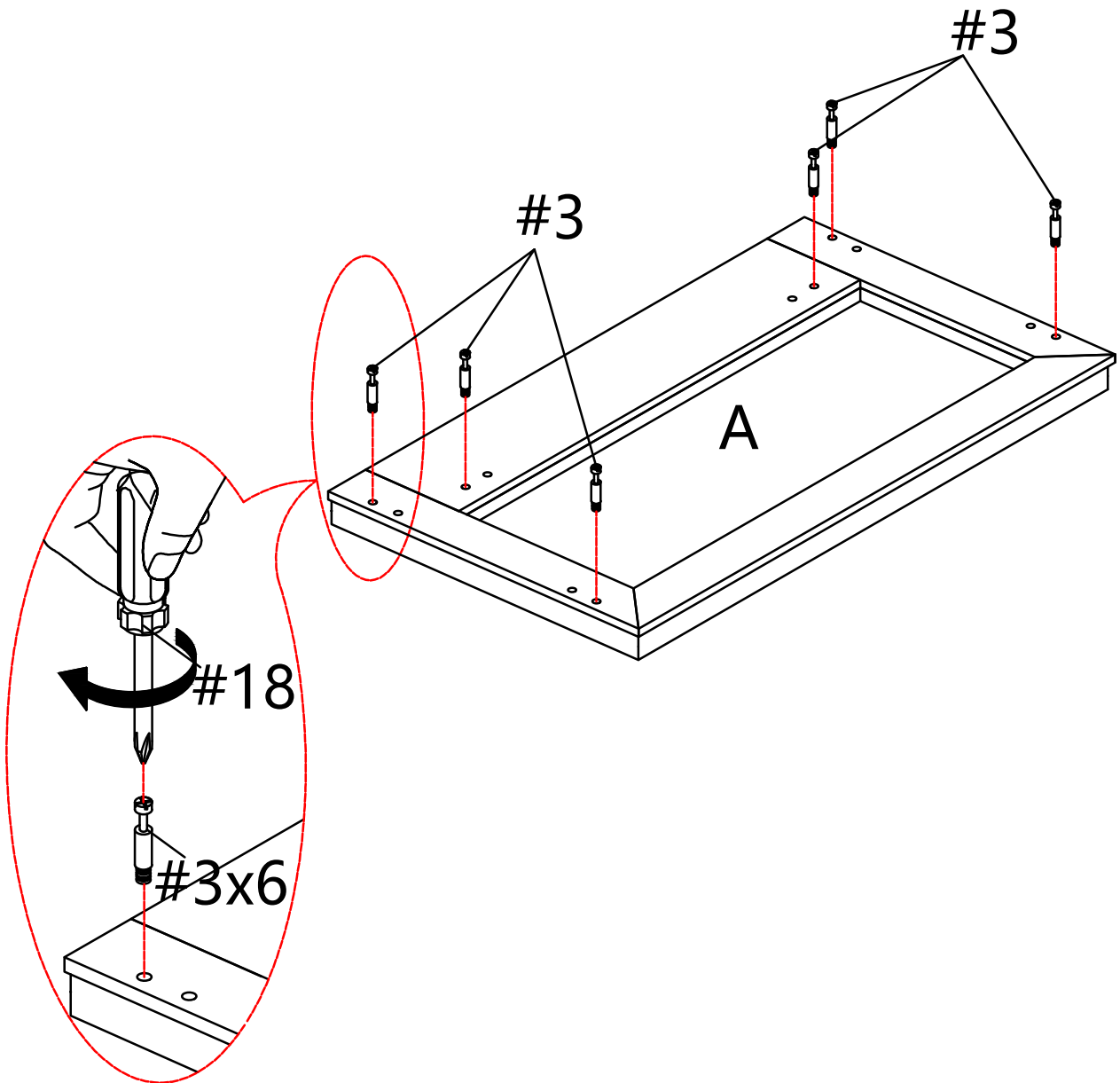

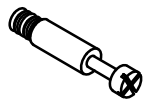
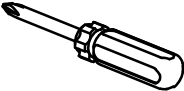

#3	x6	#18	x1
			

ASSEMBLY INSTRUCTIONS

STEP-12

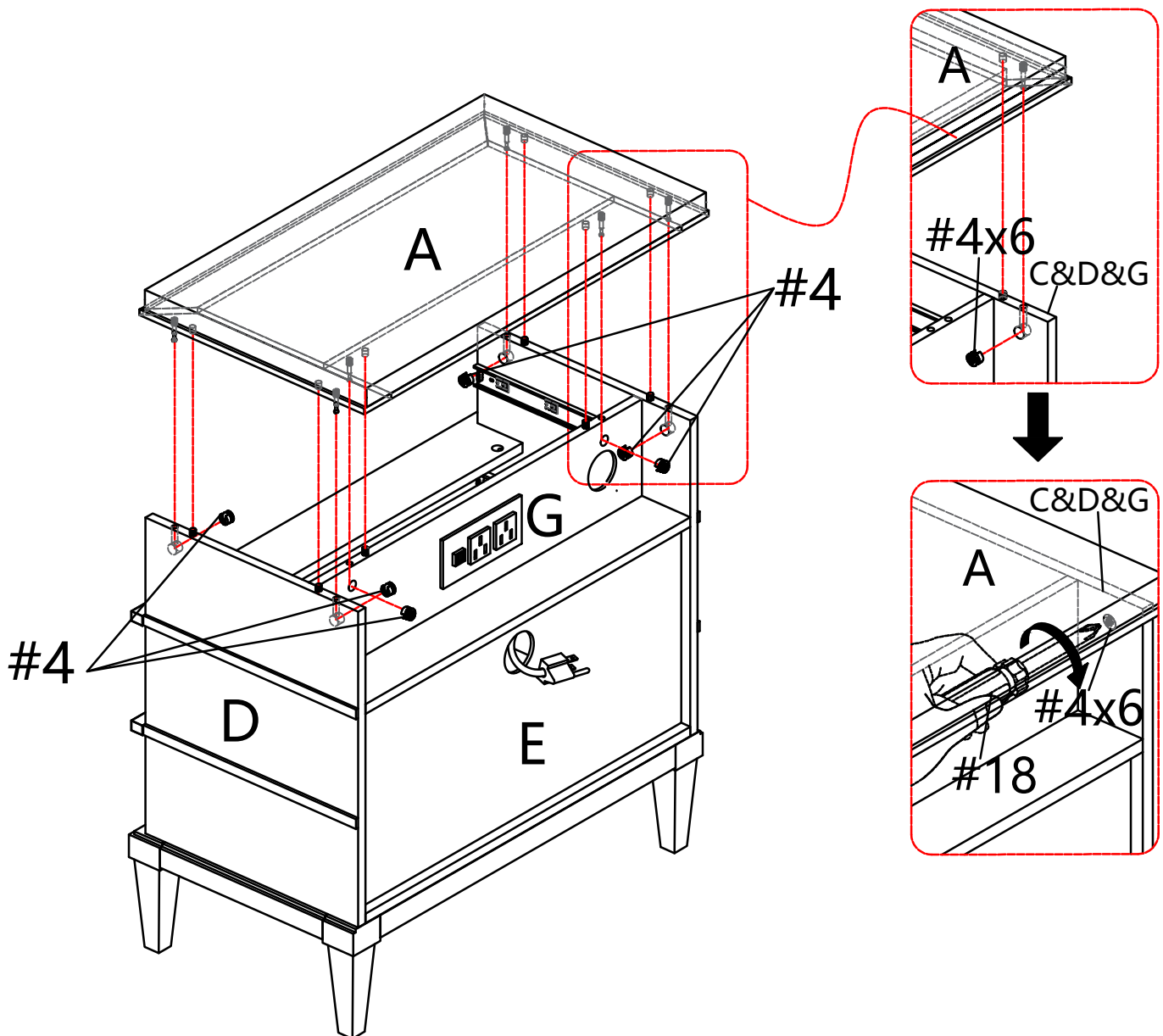
Insert top panel (A) into the preassembly unit at step 11, make sure all holes aligned, and then insert cam bolt #4 into the corresponding hole of side panel (C)&(D)&(G), tighten cam bolt #4 with screwdriver #18.

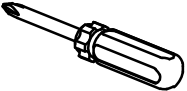

#4	x6	#18	x1
			
Ø15*12.5MM			

ASSEMBLY INSTRUCTIONS

STEP-13

Attach the rear panel (E) to the front panel (F), side panels (D)&(C) and base panel (B) using screw #10 and plastic part #14, tighten screw #14 with screwdriver #18.

Use wire cover #15 to with part G align the hole in the wire cover.

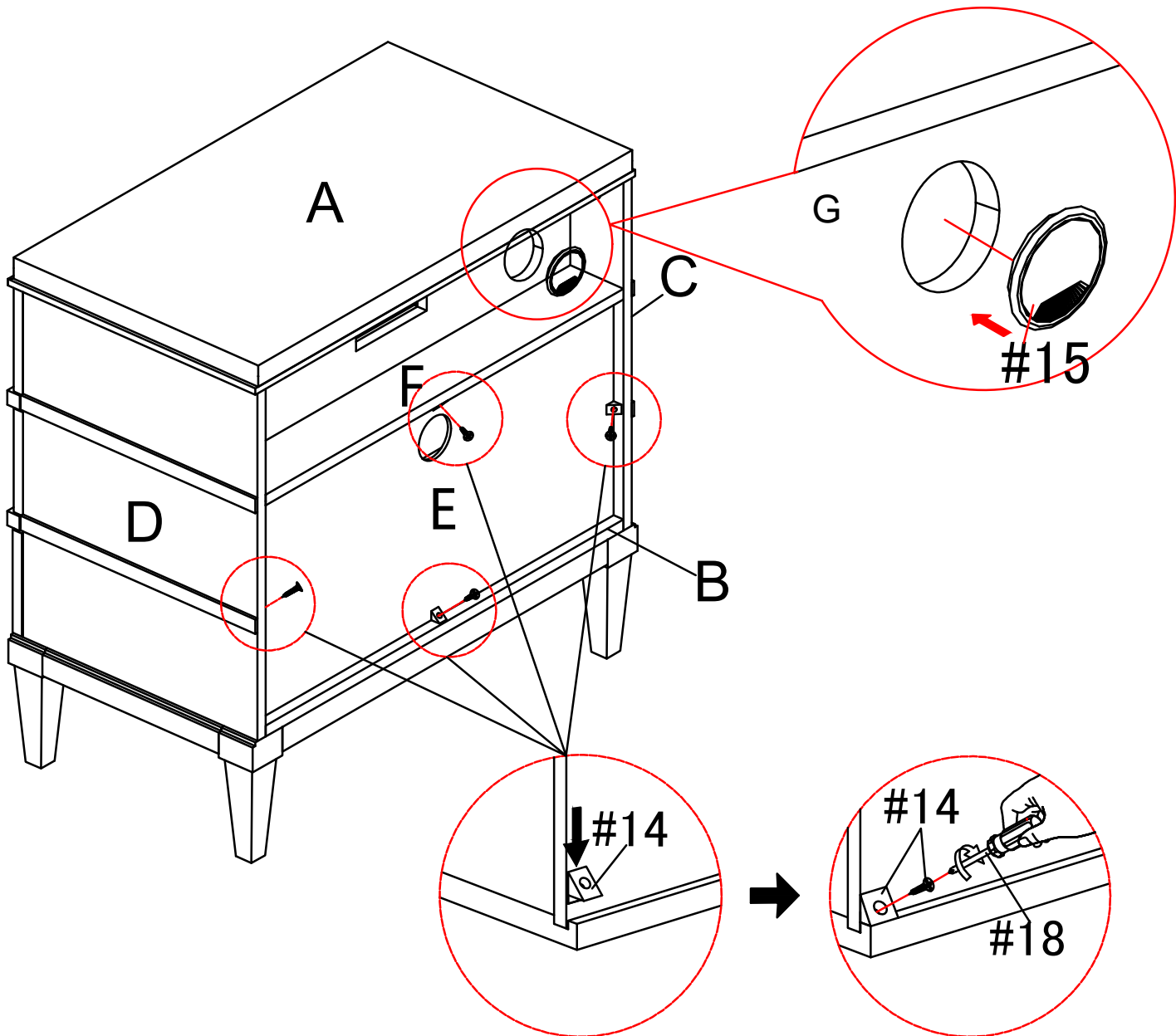

#15	x1	#14	x4	#18	x1
					

ASSEMBLY INSTRUCTIONS

STEP-14

1. Use screw #12 to attach drawer side (K) & (L) to drawer back (J), tighten screw #12 with screwdriver #18, and slide in the part (M) into the groove in part (K) & (L). make sure they are also in groove in part (J).

2. Use screw #12 to attach drawer side (N) & (O) to drawer back (J), tighten screw #12 with screwdriver #18, and slide in the part (P) into the groove in part (N) & (O). make sure they are also in groove in part (J).

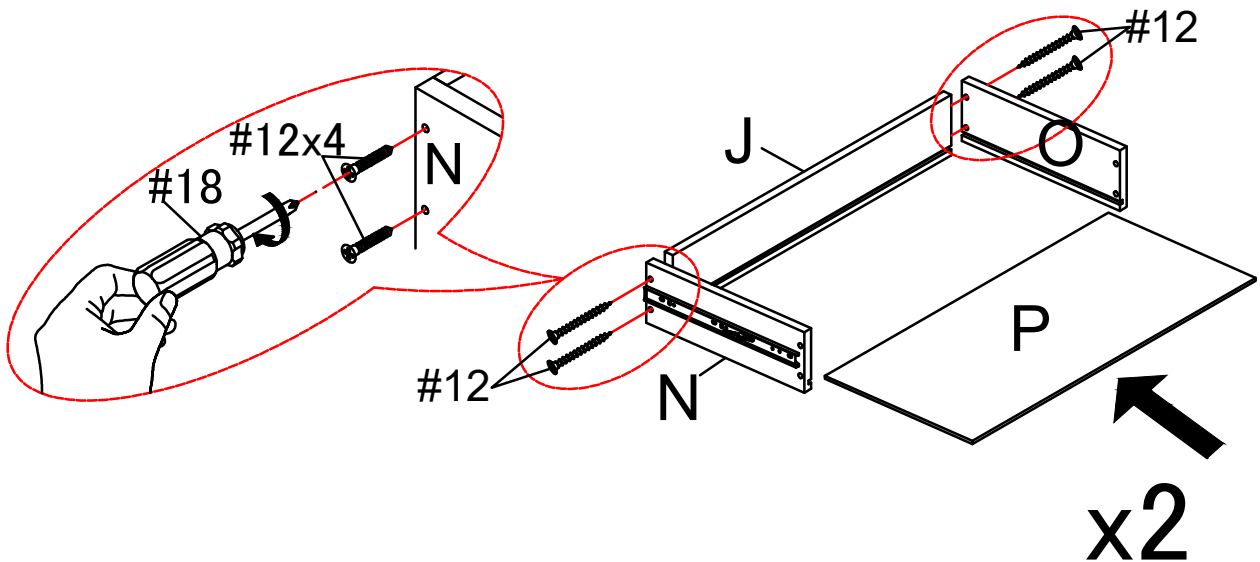
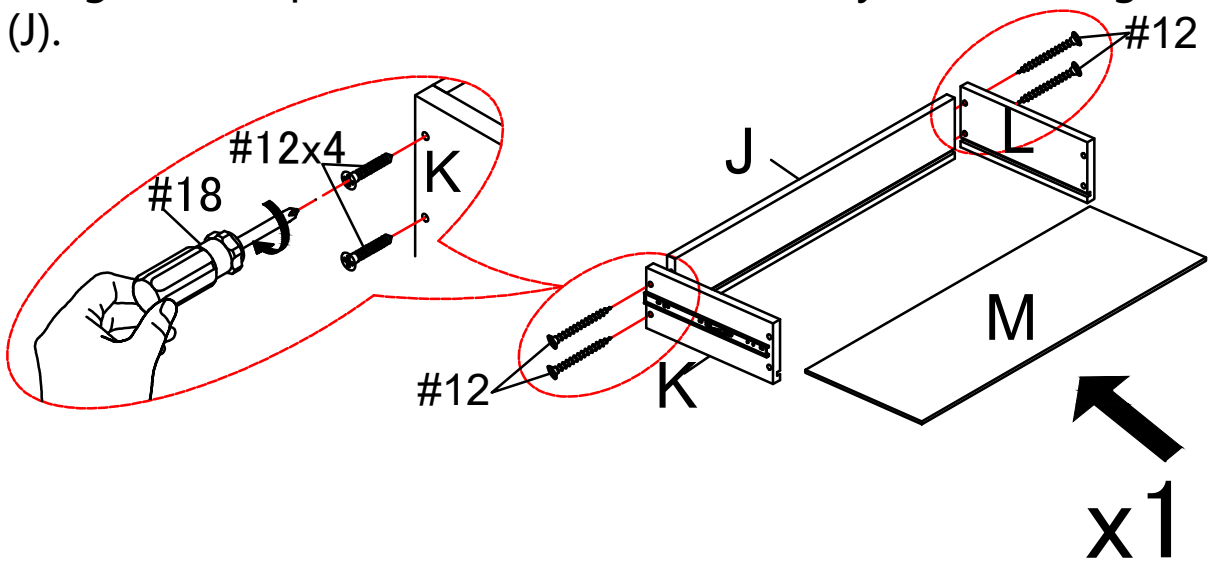

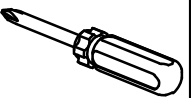

#12	x12	#18	x1
			
ø8*1-1/2"			

ASSEMBLY INSTRUCTIONS

STEP-15

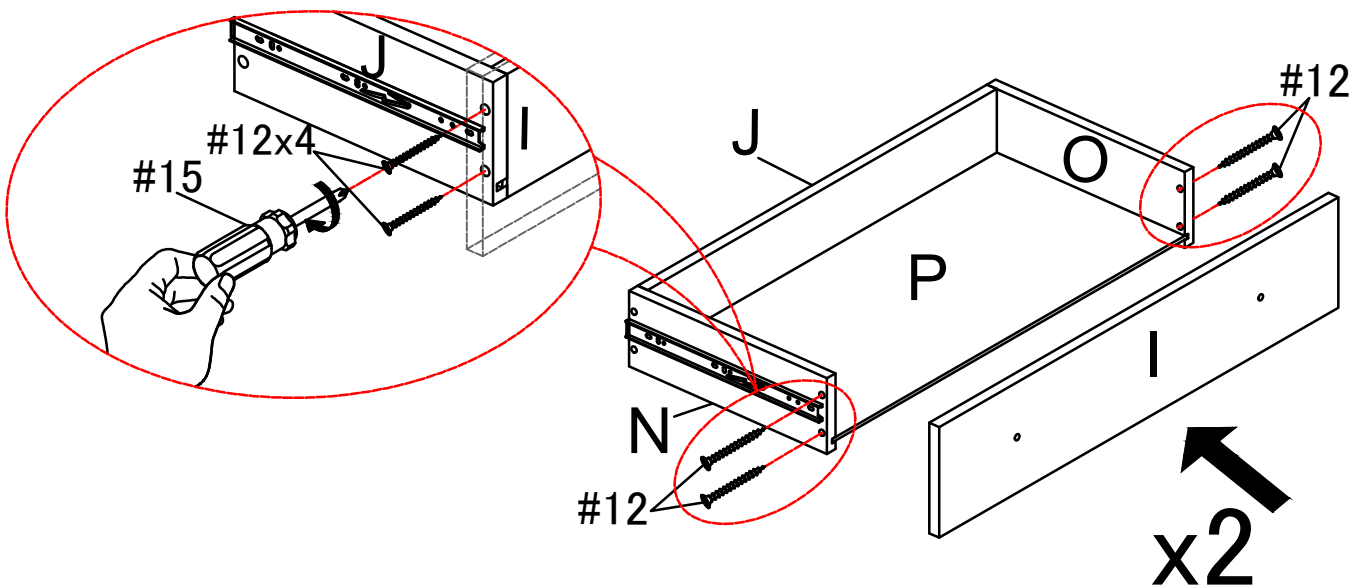
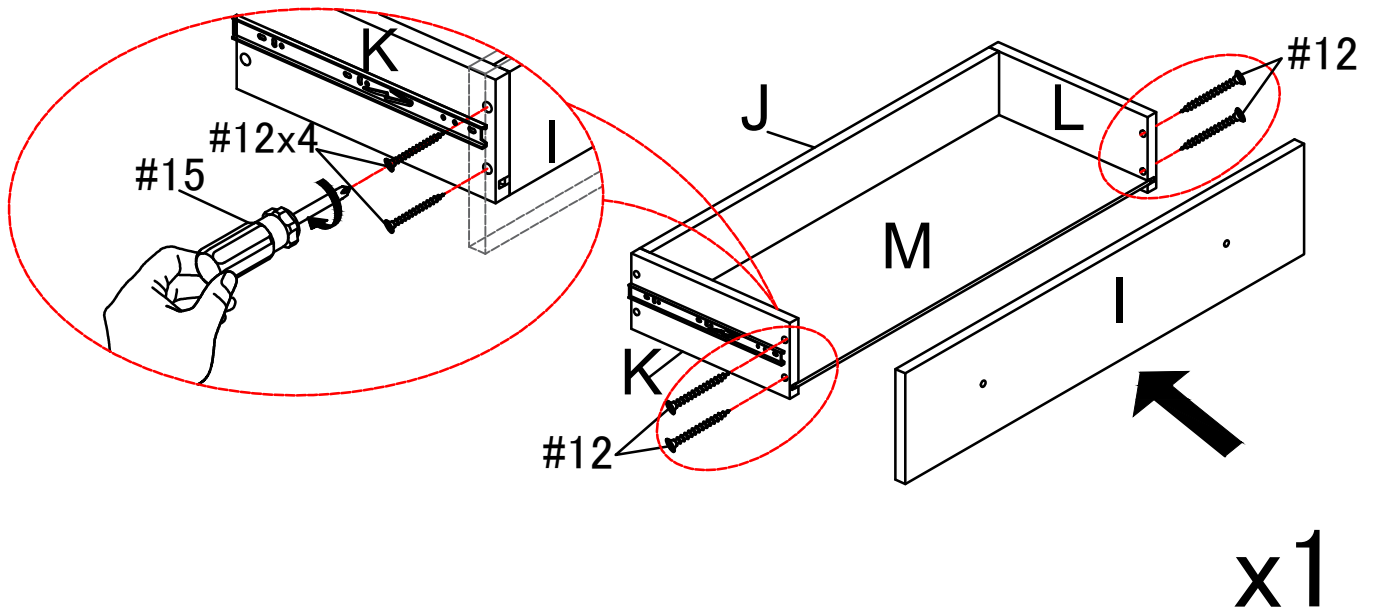
Insert drawer front (I) into preassembly step 14, make sure all holes aligned and insert screw #12 into the corresponding hole of drawer side panel(K)&(L)&(N)&(O) , tighten screw #12 with screwdriver #18.

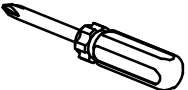

#12	x12	#18	x1
			
ø8*1-1/2"			

ASSEMBLY INSTRUCTIONS

STEP-16

Use bolt #1 to attach handle #1 to drawer front(I), tighten bolts #1 with screwdriver #18.

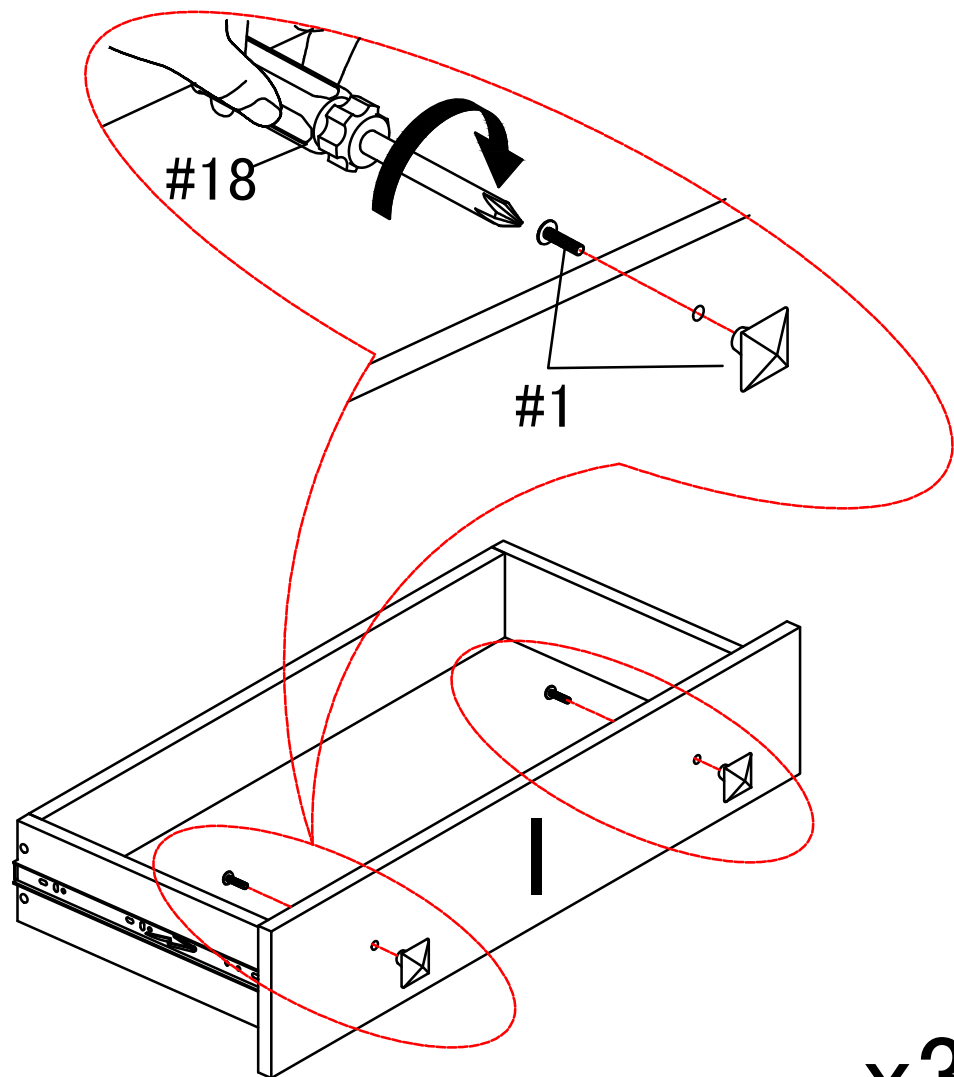

x3

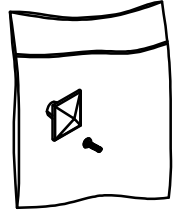
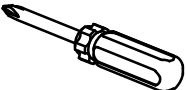
#1	x6	#18	x1
			

ASSEMBLY INSTRUCTIONS



Attention: When installing the drawer, slide the steel ball slide rail of side panel to the most front as picture show.

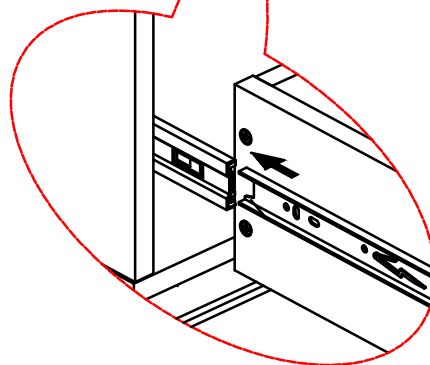
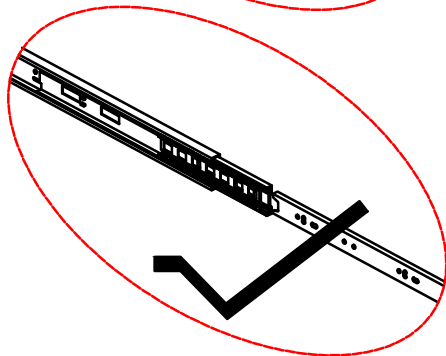
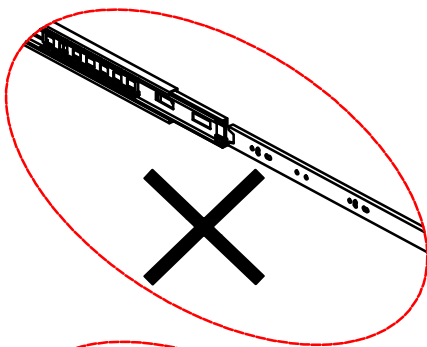
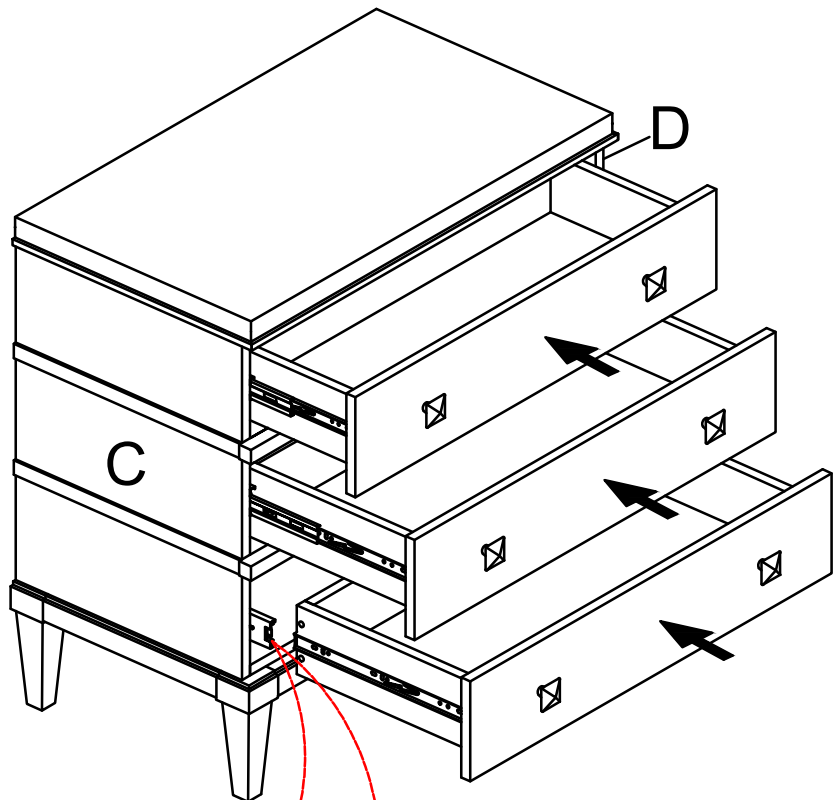

ASSEMBLY INSTRUCTIONS

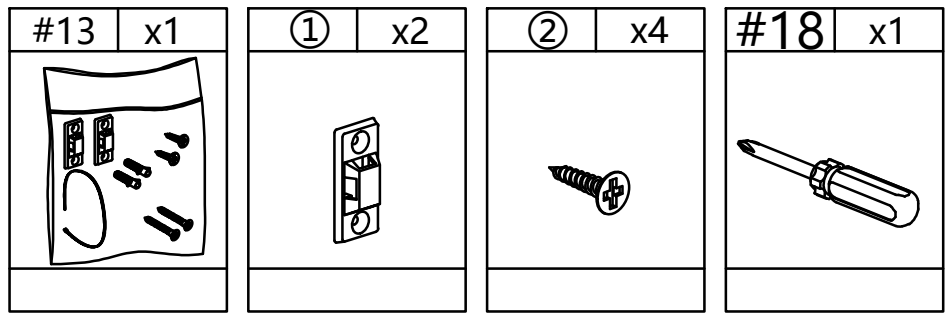

STEP-17

Use screw ② to attach bracket ① to top panel (A), tighten screw ② with screwdriver #18.

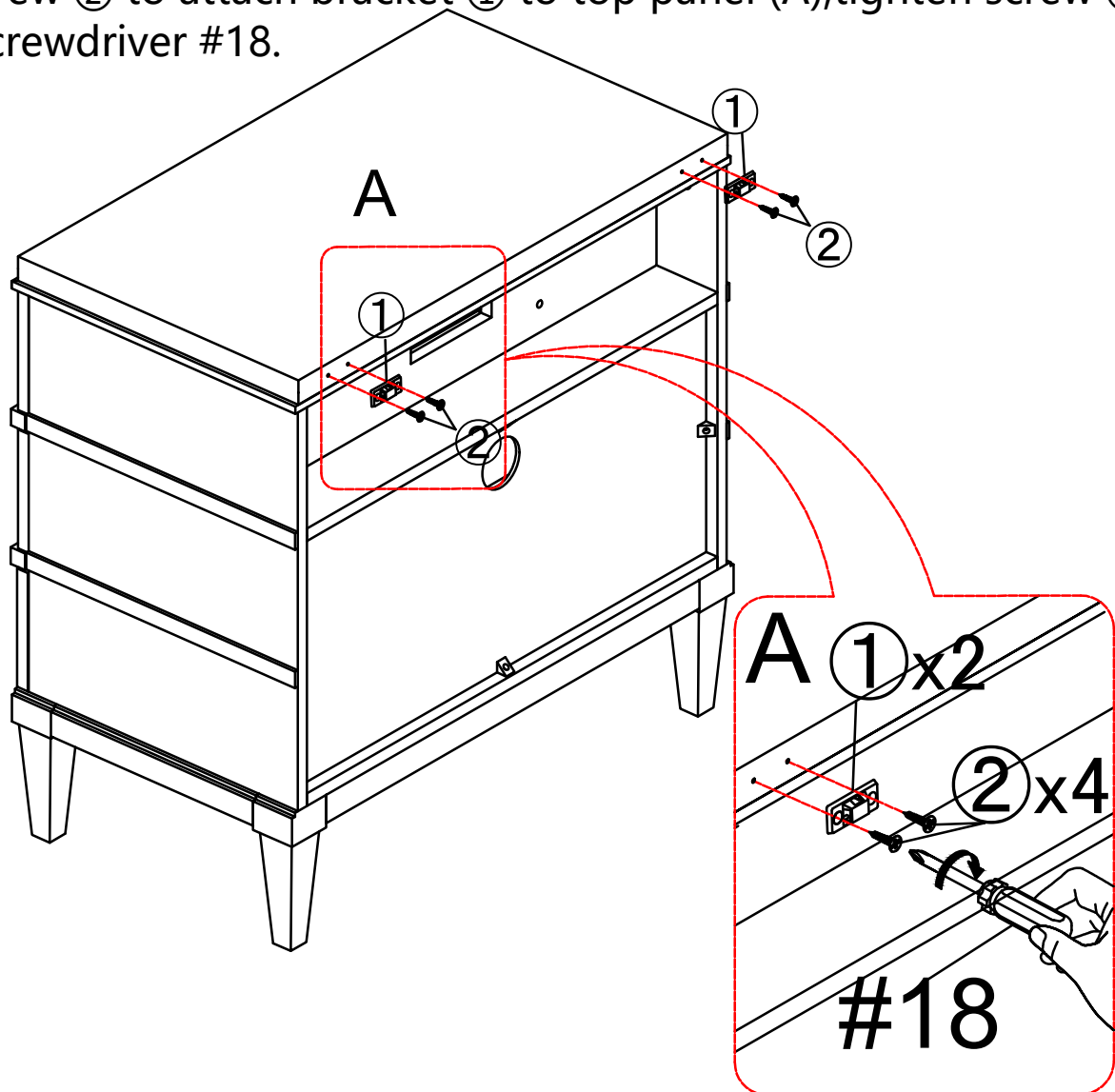

ASSEMBLY INSTRUCTIONS

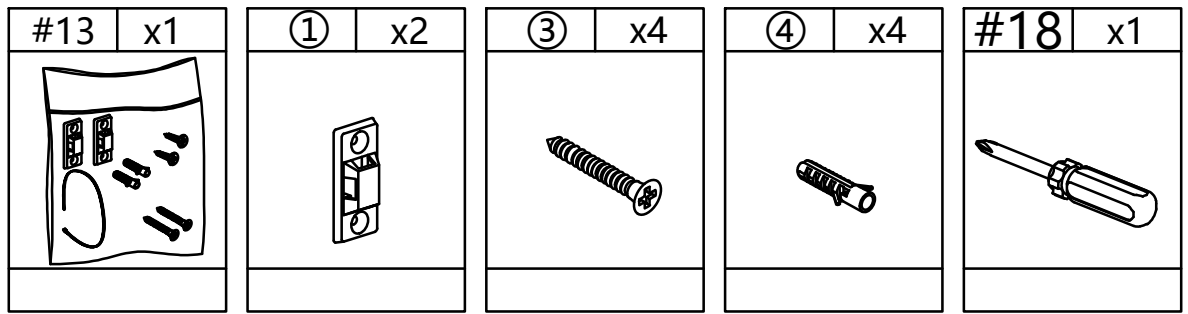

STEP-18

1. Mark the position on the wall, that corresponds to the location of bracket ① on the panel A; Drill and insert the expandable screw ④ by hammer.
2. Assemble the bracket ① to the wall. Align the hole in the bracket ① with the expandable screw ④, use screw ③ to attach it, tighten screw ③ with screwdriver #18

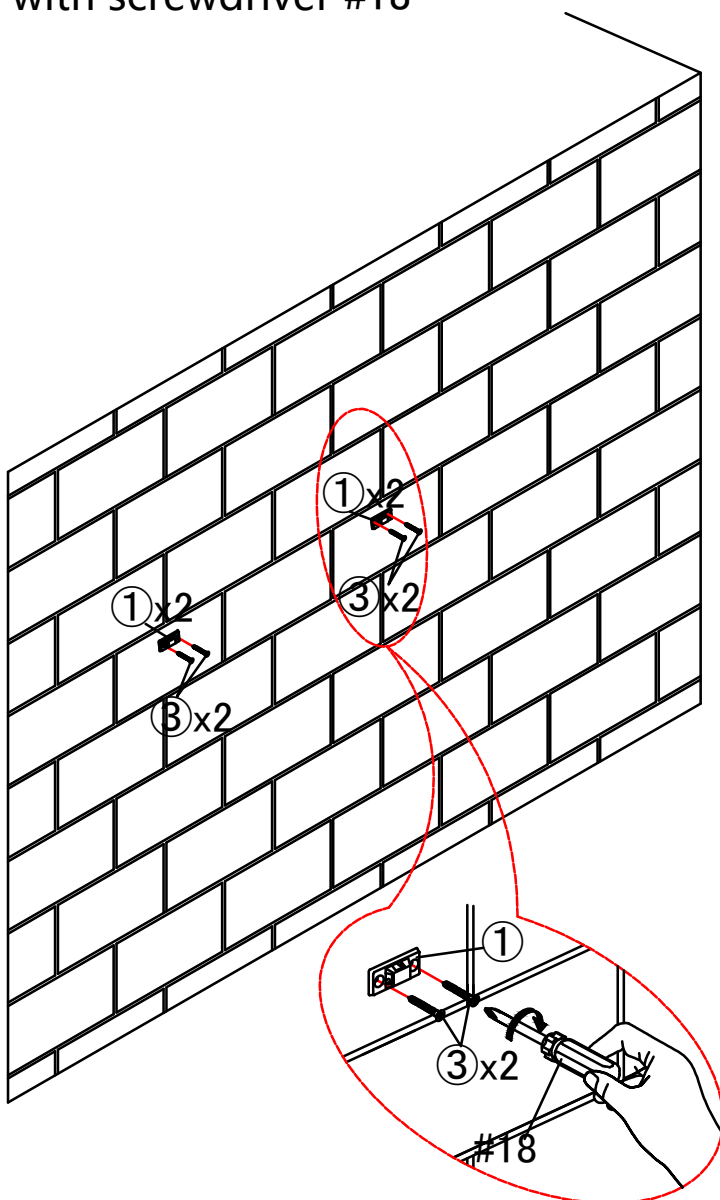

NOT PROVIDED

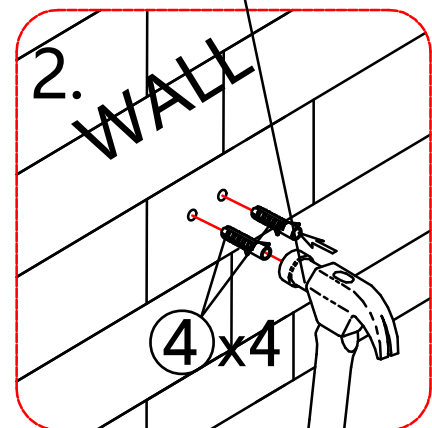
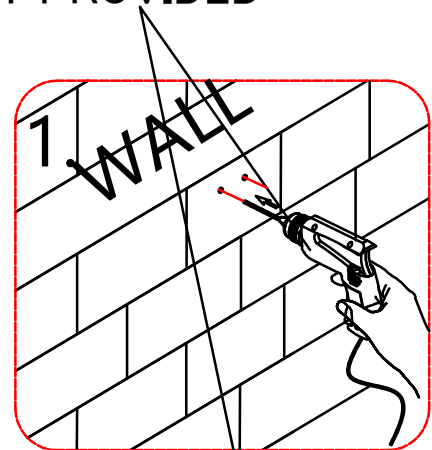

ASSEMBLY INSTRUCTIONS

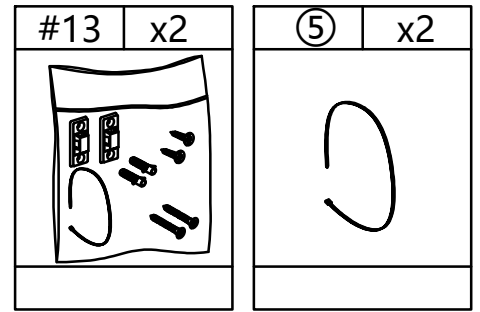

STEP-19

3. Let the plastic belt ⑤ pass through bracket ① and pull tightly.

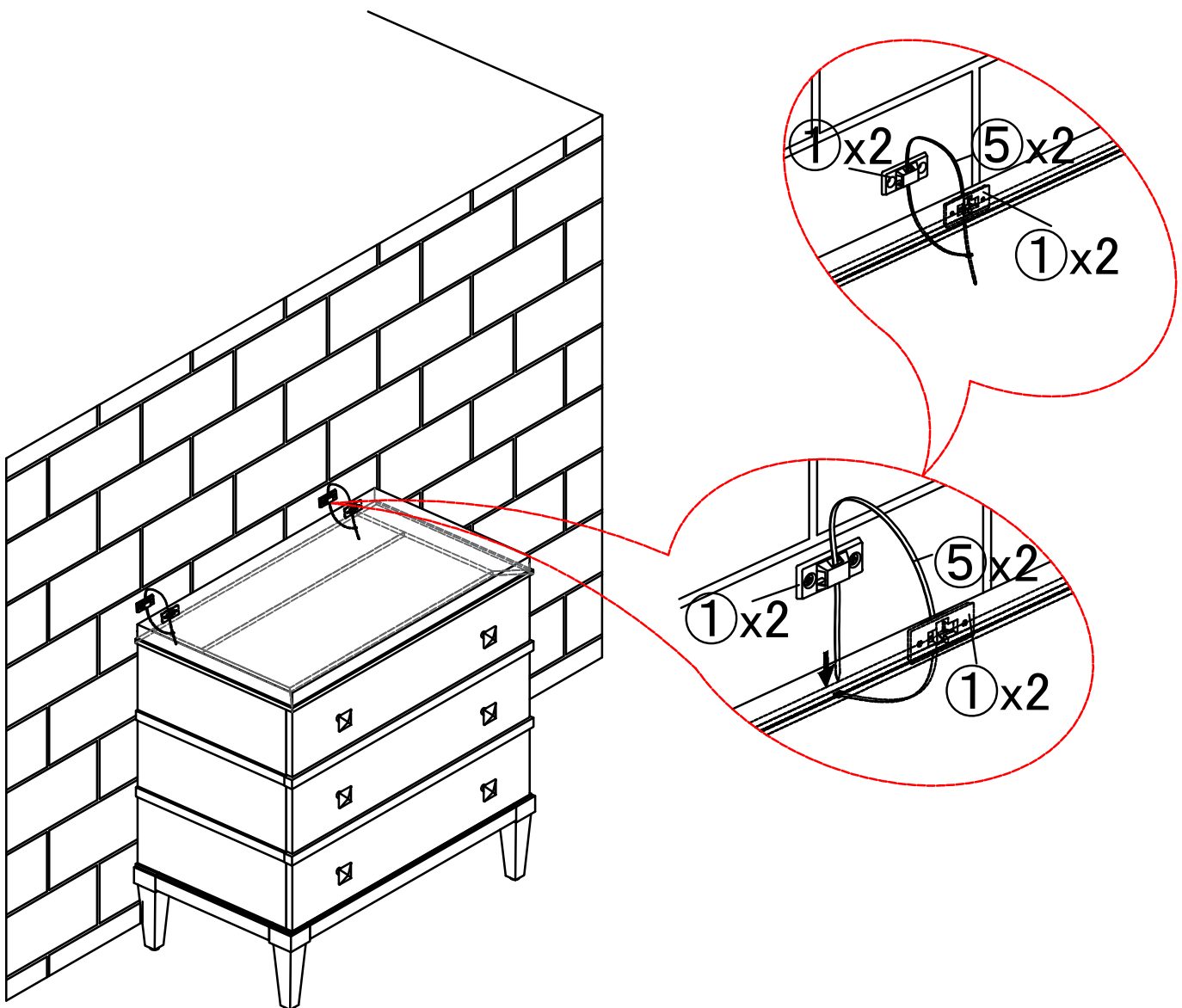

WARRANTY

1. We strive to offer high-quality products, and we also try our best to satisfy each and every customer that orders from us with product or service as needed.
2. We provide 30 days warranty starting from the time you receive the item. Each customer must provide a record of their order such as the order number, or item receipt for any items that are out of the warranty period you may also still receive.
3. Replacement parts by purchasing them with our company if they are available.

Are you having difficulty
With assembly? Missing parts?
Please send email with your order No to
customerservice@hulalahome.com
For return, please check the return policy with
the retailer or market place you bought from.

Appreciate your purchasing from us.
Pop up your life by our furniture piece!