

HULALA

H O M E

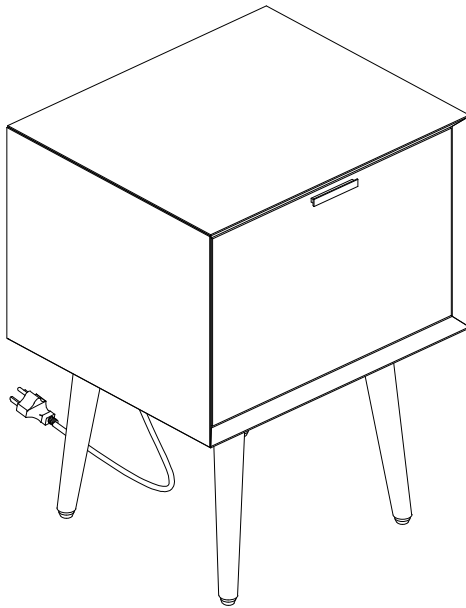

ITEM NO.NSYL0857

NOTE:

This brochure contains IMPORTANT safty info. Please read and keep for future reference.

MAINTAINANCE AND WARNING

- 1.Keep furniture away from heat sources.
- 2.Do not clean furniture with harsh cleaner or polishes.Do not use detergents,solvents,abrasives,spray packs or leather cleaner. Use non-color mild soa with warm water to clean spills(Mix 1:10 soap to water).
- 3.Do not place furniture under direct sunlight,material will possibly fade over time.
- 4.Do not use on site dry cleaning machine.Children should not climb or jump on the furniture.
- 5.Do not write on furniture that is not protectedby a padded barrier.
- 6.Not for commercial use,only for residential use.



Weight Limitation

70 LBS

EXPLOSIVE VIEW

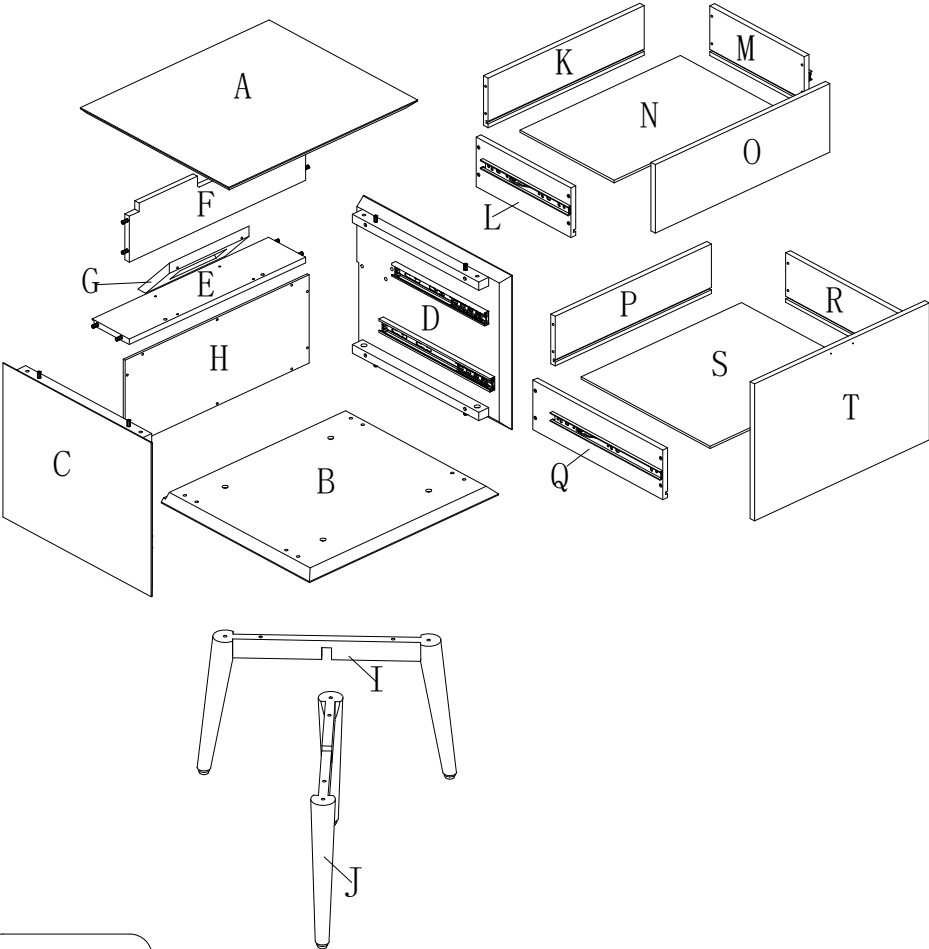

2 PERSONENS



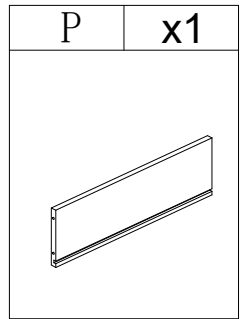
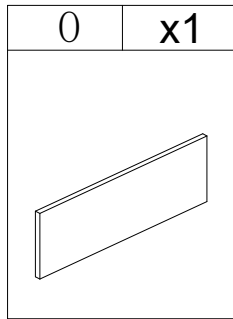
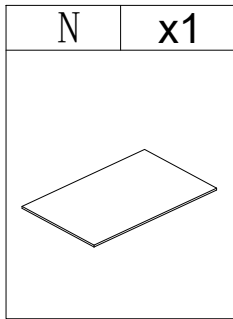
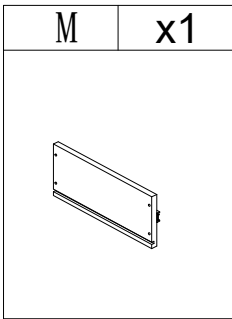
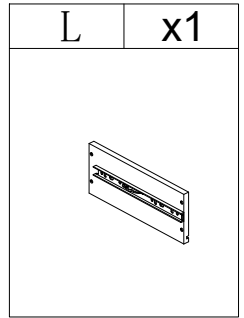
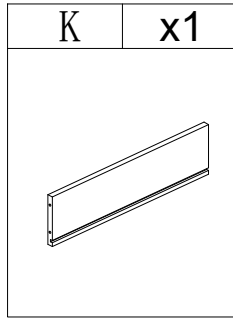
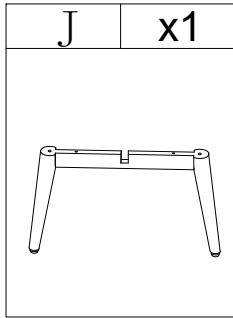
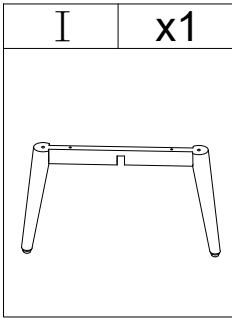
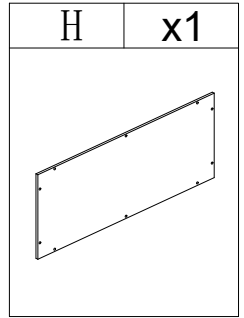
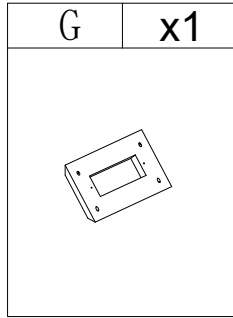
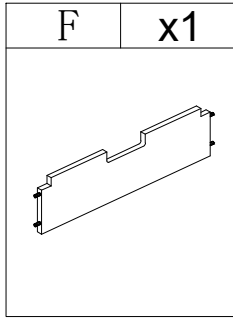
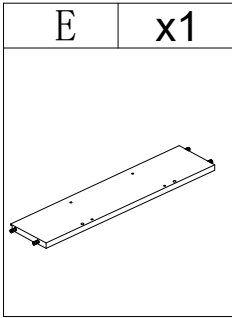
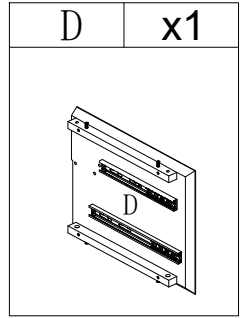
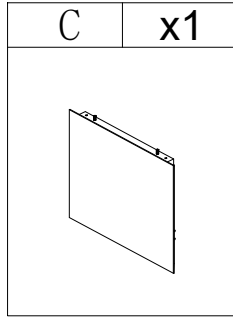
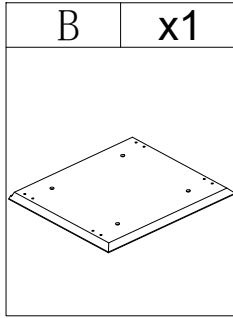
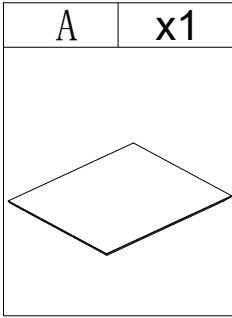



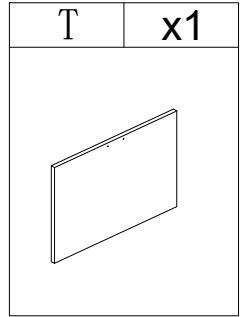
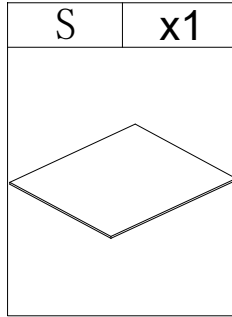
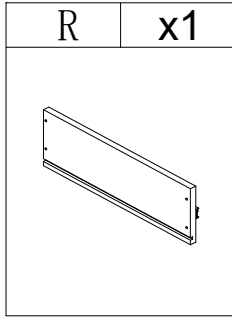
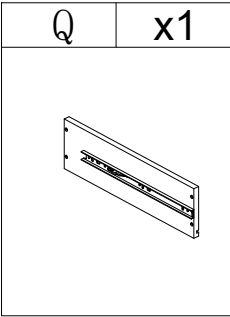

PARTS LIST 1



PARTS LIST 2





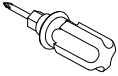

HARDWARE LIST

#1	x2	#2	x2	#3	x1	#4	x22	#5	x1	#6	x10
											
Ø4*15MM		Ø3*12MM				Ø4*25MM				Ø3*15MM	
#7	x4	#8	x12								
											
Ø6*45MM		Ø6*22MM									

TOOL LIST

#16	x1	#17	x1
			
M6			

HARDWARE SPARE LIST

#7	x1	#8	x1	#4	x1	#6	x1
							
Ø6*45MM		Ø6*22MM		Ø4*25MM		Ø3*15MM	

ASSEMBLY INSTRUCTIONS

STEP-1

1. Combine part I and part J, making sure their grooves face each other.

2. Attach the assembled parts (J&I) to the bottom panel B with bolt #7, ensure the corresponding holes are aligned.

1:

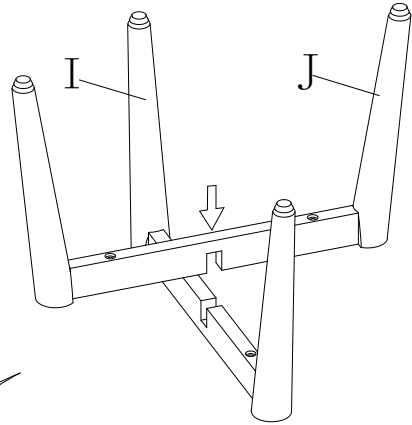

2:

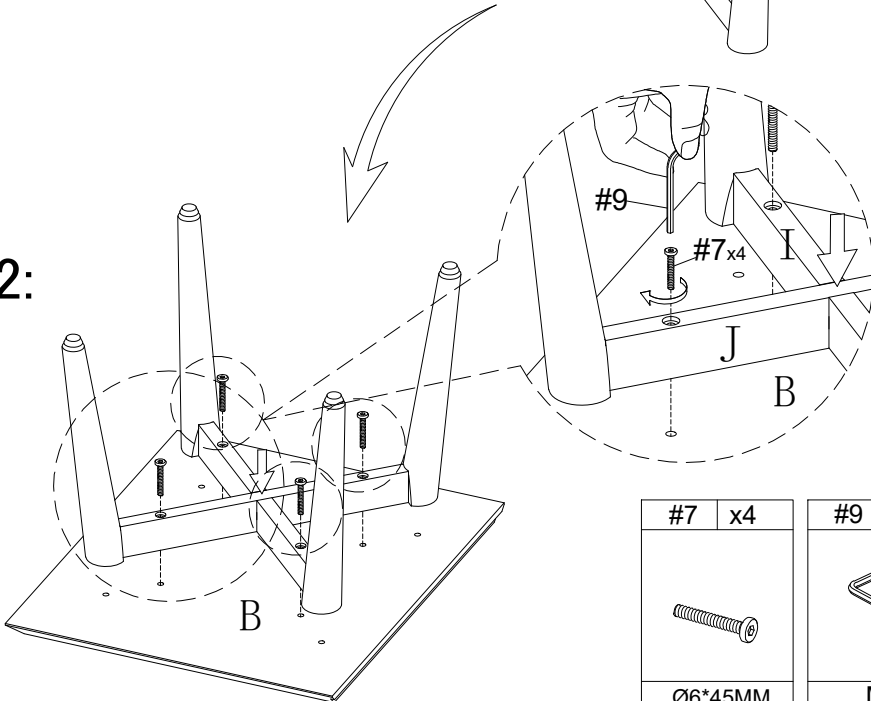

#7	x4
	
Ø6*45MM	

#9	x1
	
M6	

ASSEMBLY INSTRUCTIONS

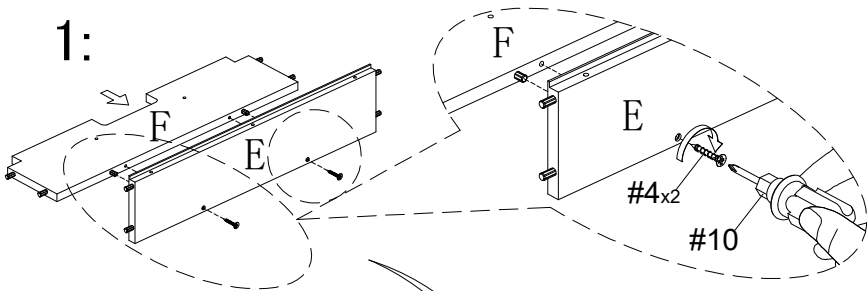

STEP-2

1. Insert part (E) into part (F), make sure all holes aligned and use screw #4 to attach them, tighten screw #4 with screwdriver #10.
2. Insert side panel (C&D) into panel (E&F), make sure all holes aligned as picture show.

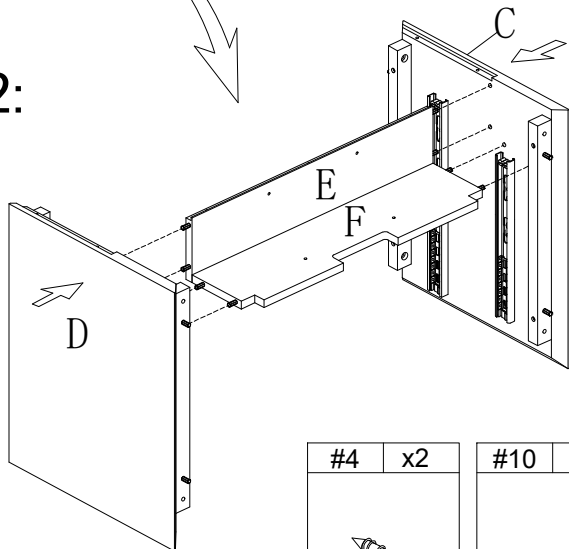

2:





#4	x2	#10	x1
			
Ø4*25MM			

ASSEMBLY INSTRUCTIONS

STEP-3

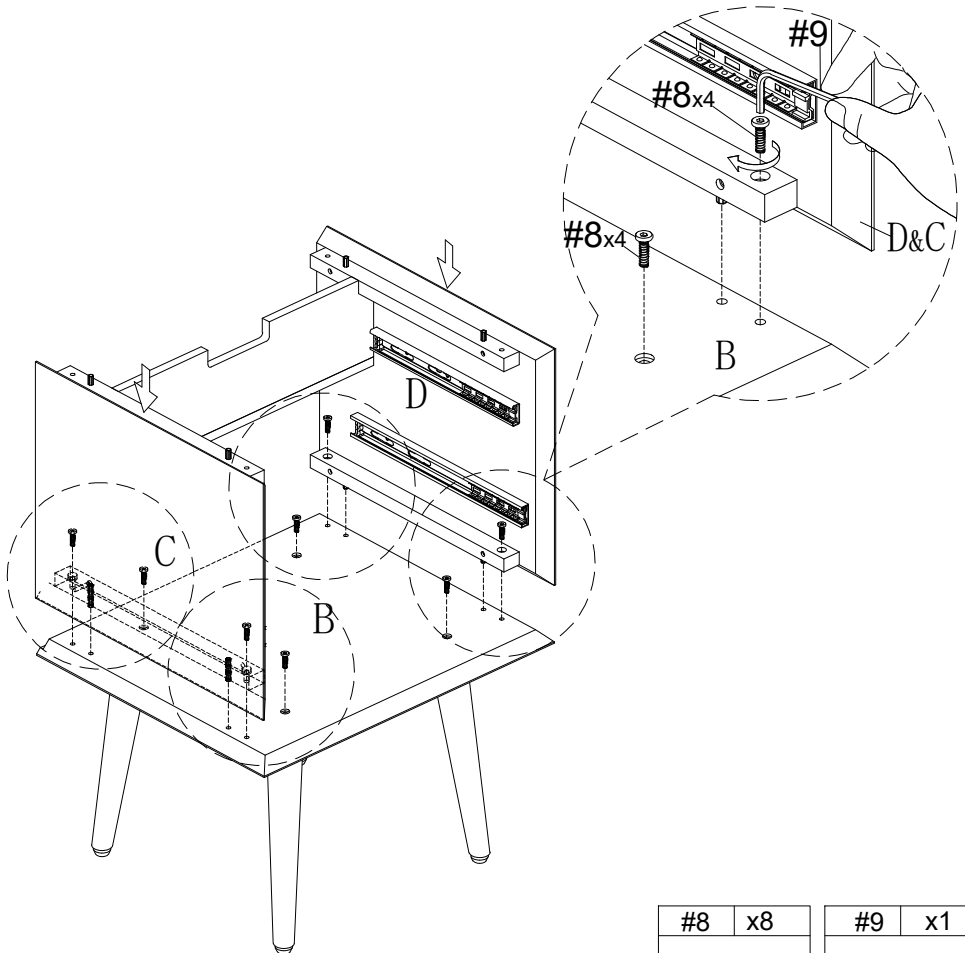
1. Insert preassembled step 2 into the corresponding hole of bottom panel (B), make sure all holes aligned and use Bolt#8 to attach them tighten bolt#8 with Allen Key #10.



#8	x8
	
Ø6*22MM	

#9	x1
	
M6	

ASSEMBLY INSTRUCTIONS

STEP-4

1.insert back panel(H) into the groove of preassembled step 3,make sure all holes aligned and use screw#1 to attach them , tighten screw #6 with screwdriver#10.

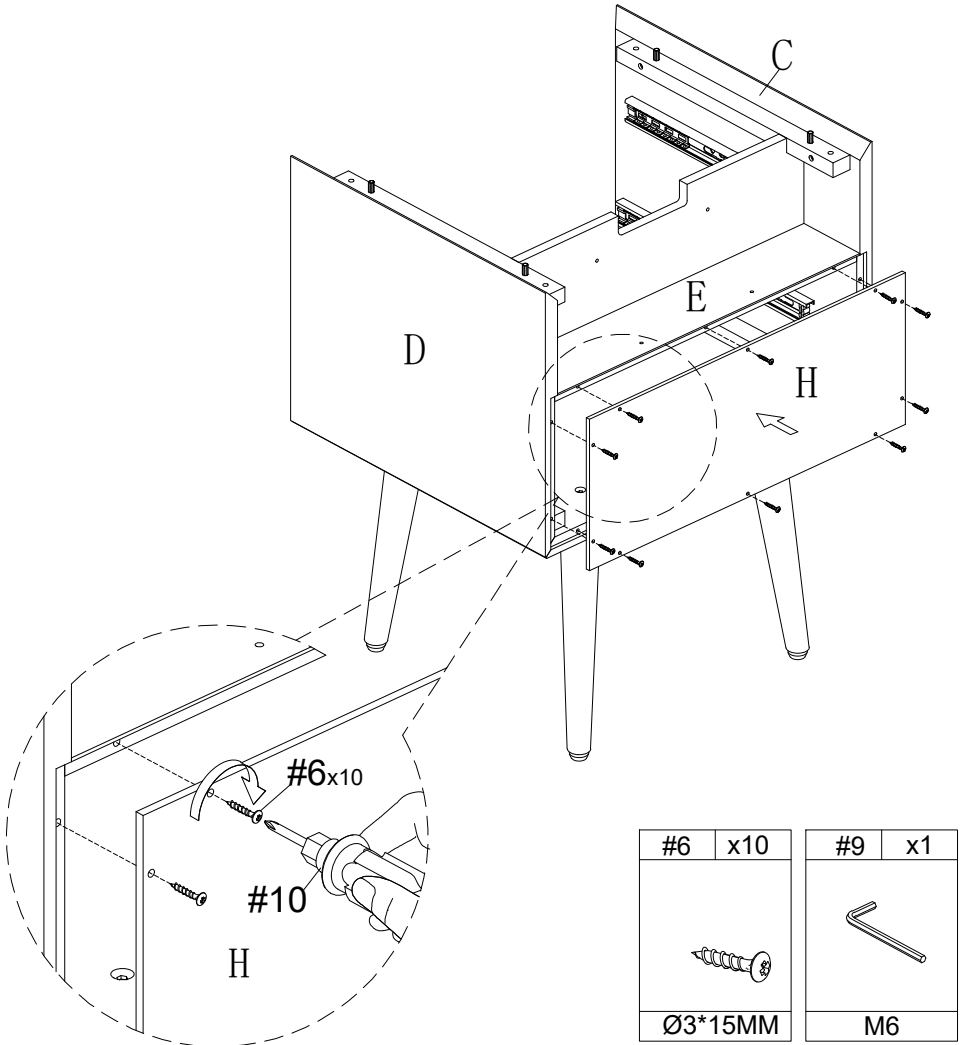



ASSEMBLY INSTRUCTIONS

STEP-5

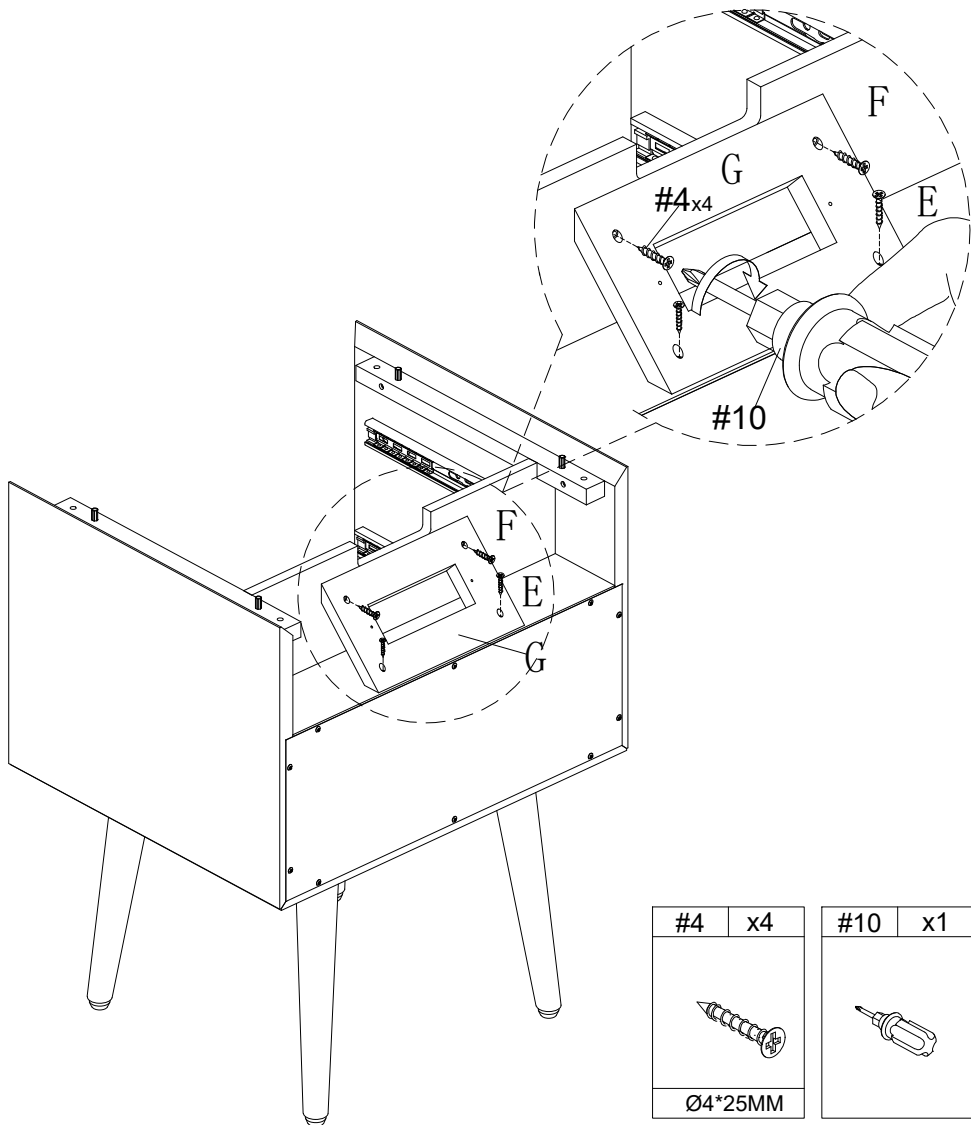
1.insert part (G)into the preassembled step 4 make sure all holes aligned and use screw #4 to attach them , tighten screw #4 with screwdriver#10.



#4	x4
	
Ø4*25MM	



#10	x1
	

ASSEMBLY INSTRUCTIONS

STEP-6

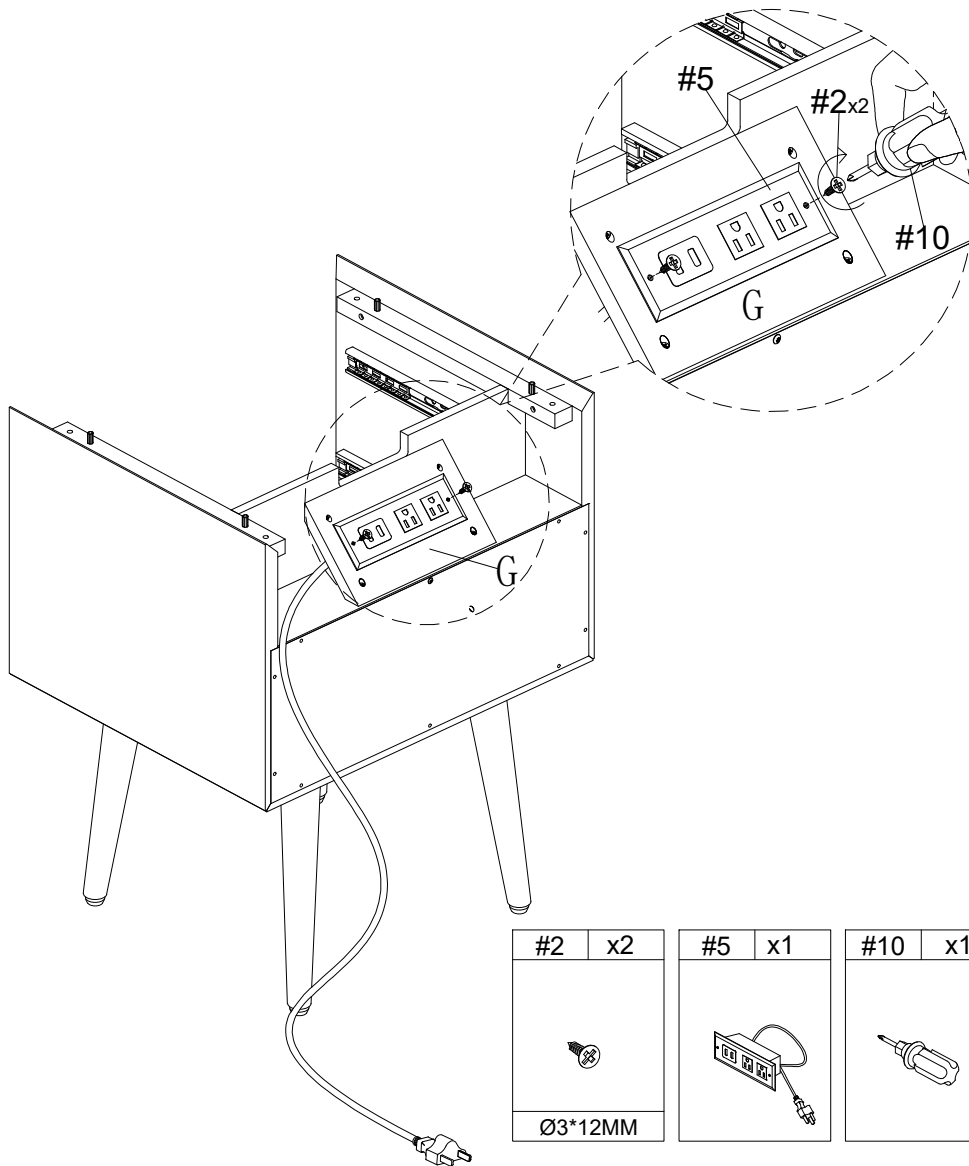
1.insert part #5 into the preassembled step 5,make sure all holes aligned and use screw#2 to attach them , tighten screw #2 with screwdriver#10.

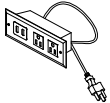



#2	x2	#5	x1	#10	x1
					
Ø3*12MM					

ASSEMBLY INSTRUCTIONS

STEP-7

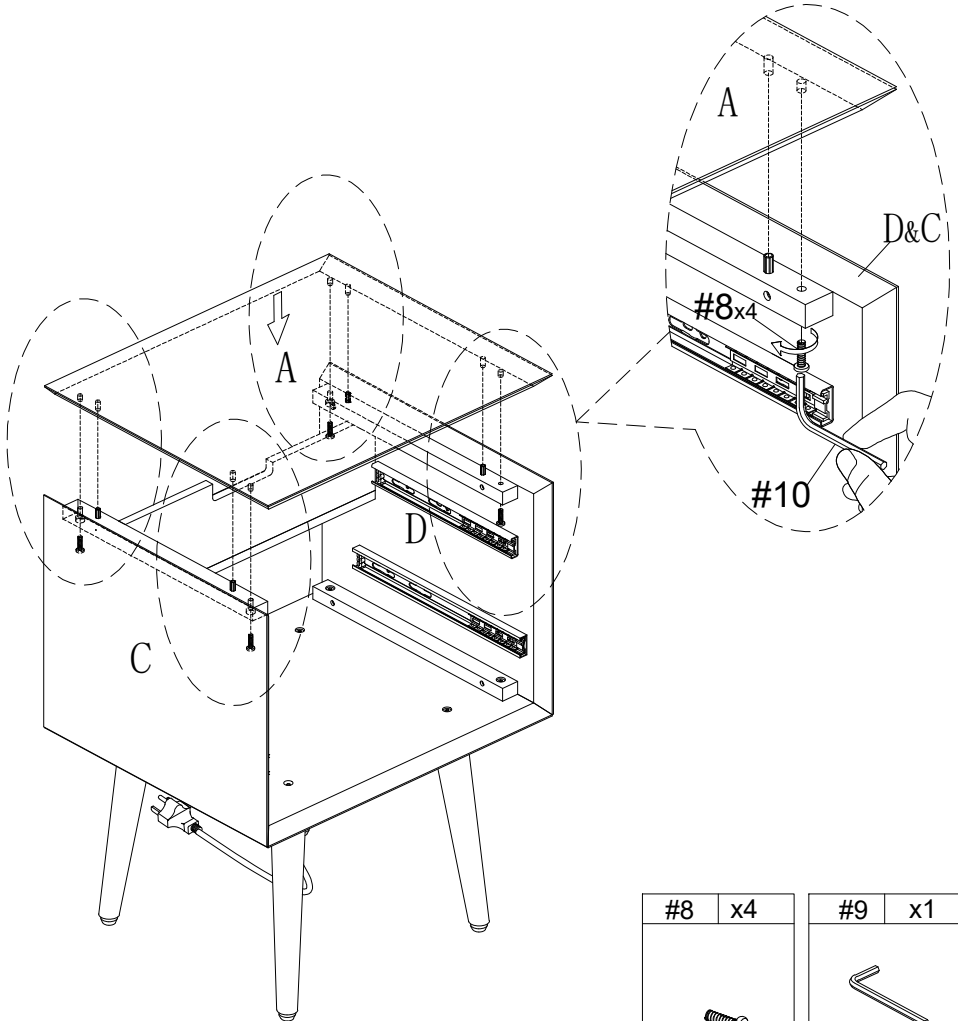
1. Insert top panel (A) into the corresponding hole of preassembled step 6, make sure all holes aligned and use Bolt#8 to attach them tighten bolt#8 with Allen Key #10.



#8	x4	#9	x1
			
Ø6*22MM		M6	

ASSEMBLY INSTRUCTIONS

STEP-8

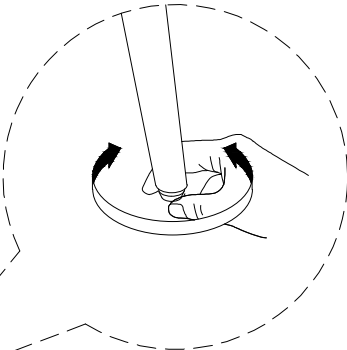
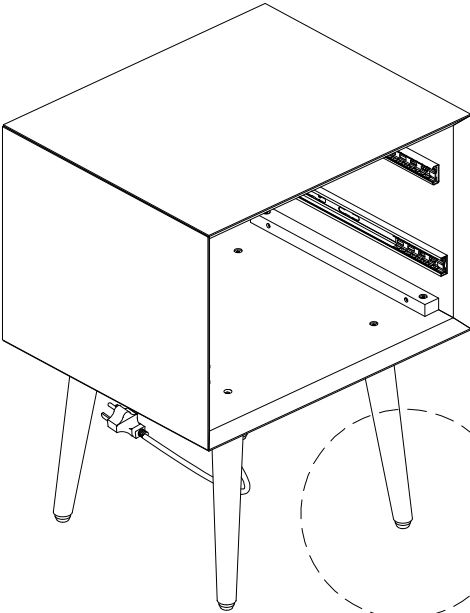

Attention:
Before the next step, adjust the feet of the locker to keep it level.

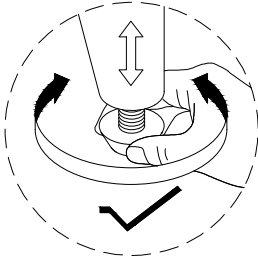
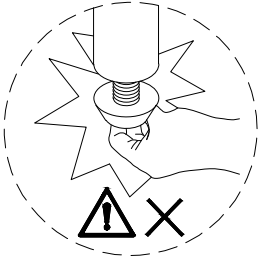

ASSEMBLY INSTRUCTIONS

STEP-9

1. Connect part (M&L) to part K using screw #4 and tighten it with screwdriver #10. Slide in the part (N) into the groove in part (L&M). make sure they are also in groove in part (K).

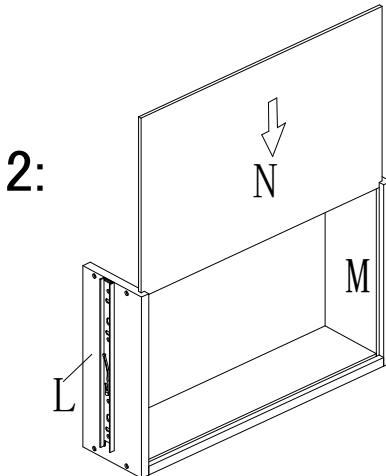
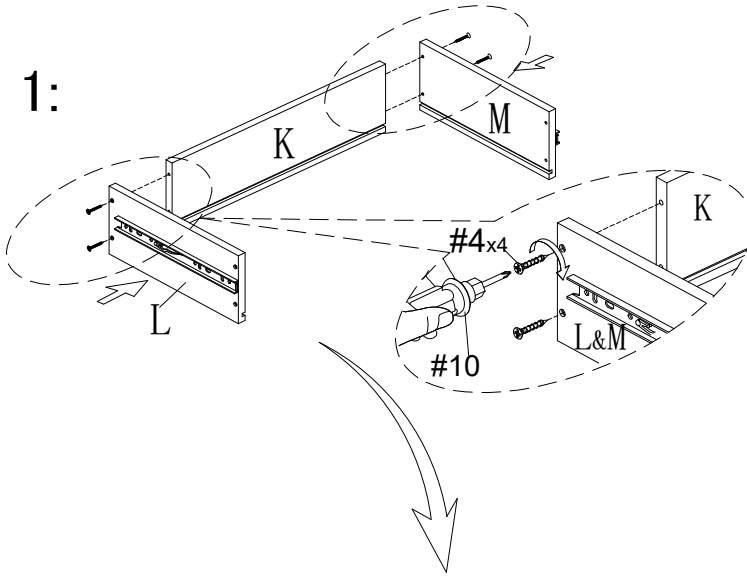

#4	x4
	
Ø4*25MM	

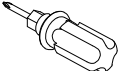
#10	x1
	

ASSEMBLY INSTRUCTIONS

STEP-10

1. Connect the (O) connection (L&M) using screw #4 , and tighten it with screwdriver #10.

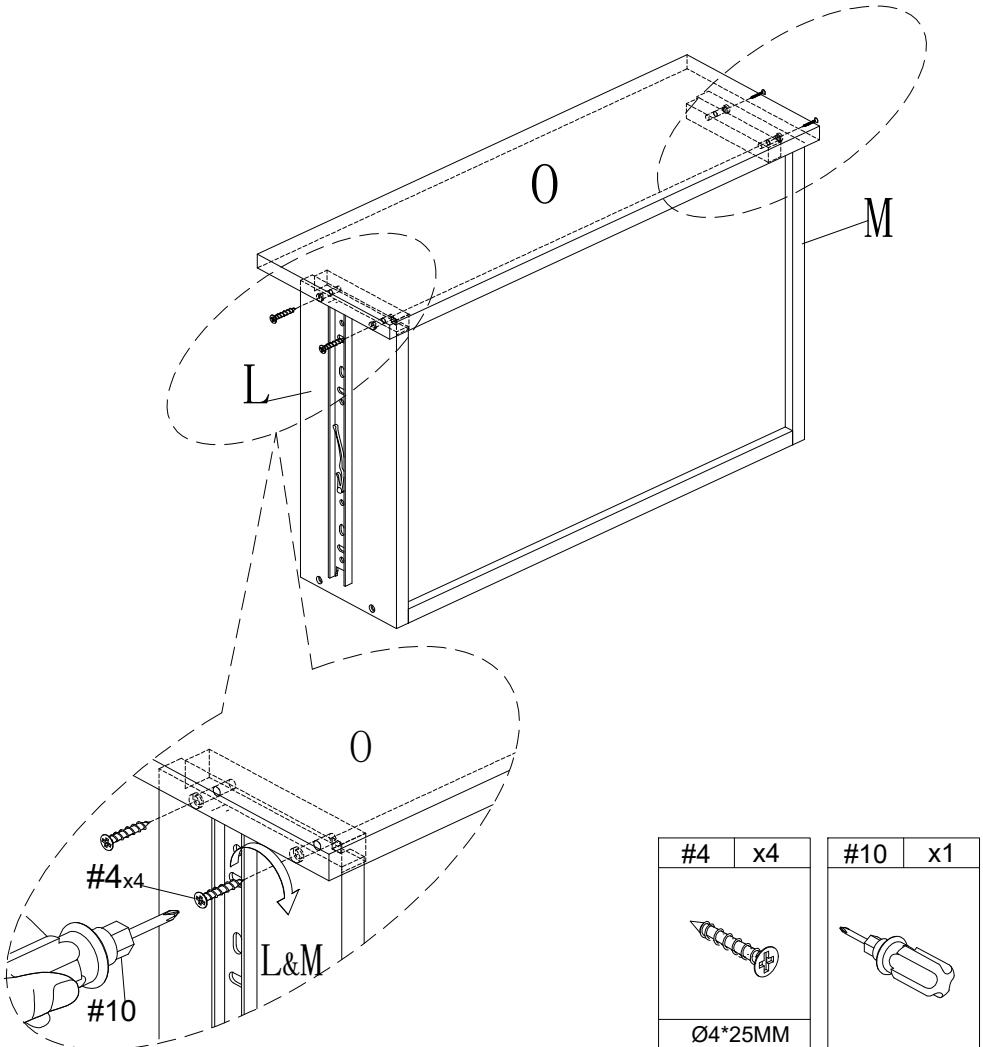

ASSEMBLY INSTRUCTIONS

STEP-11

1. Connect part (Q&R) to part P using screw #4 and tighten it with screwdriver #10. Slide in the part (S) into the groove in part (Q&R). make sure they are also in groove in part (P).

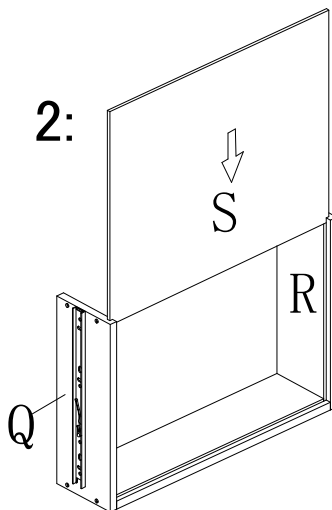
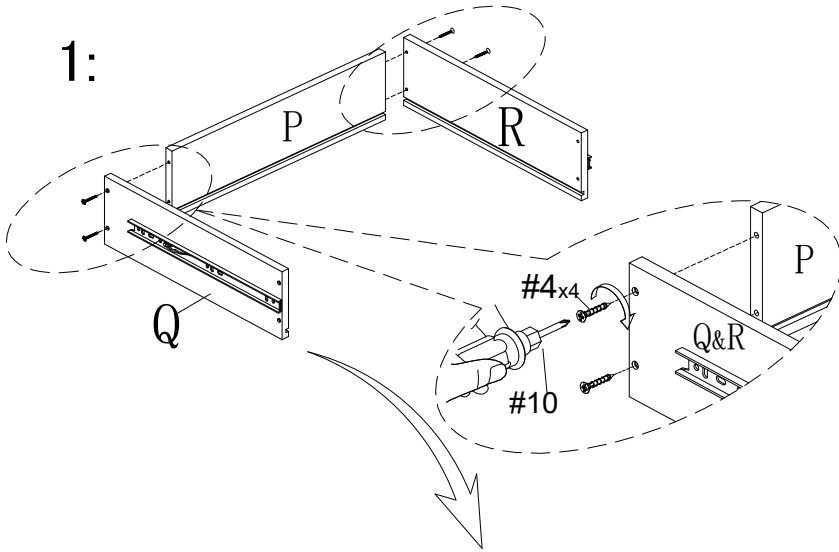

#4	x4
	
Ø4*25MM	

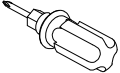
#10	x1
	



ASSEMBLY INSTRUCTIONS

STEP-12

1. Connect the (T) connection (Q&R) using screw #4 , and tighten it with screwdriver #10.

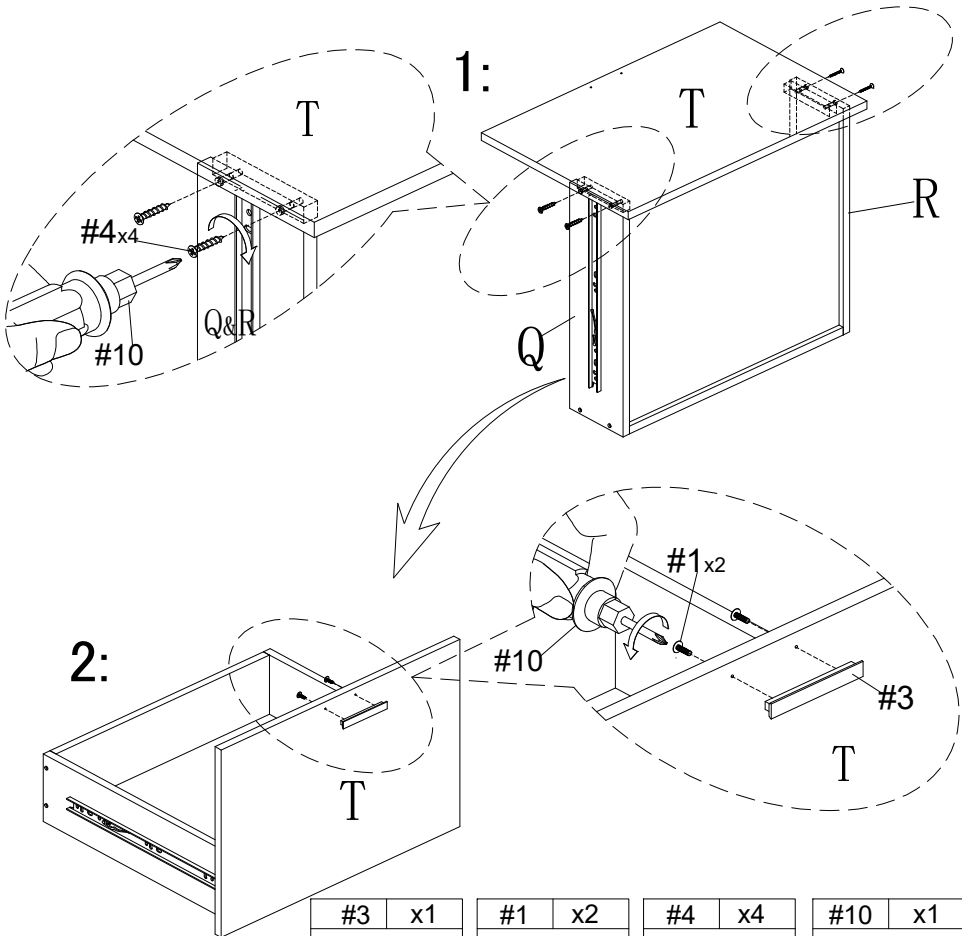
2. Use screw #1 to fix handle #3 to part T, and tighten it with screwdriver #10.

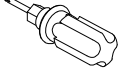

#3	x1	#1	x2	#4	x4	#10	x1
							
		Ø4*15MM		Ø4*25MM			

ASSEMBLY INSTRUCTIONS

STEP-13



Attention: When installing the drawer, slide the steel ball slide rail of side panel to the most front as picture show.

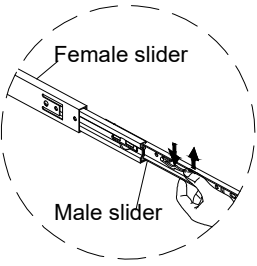
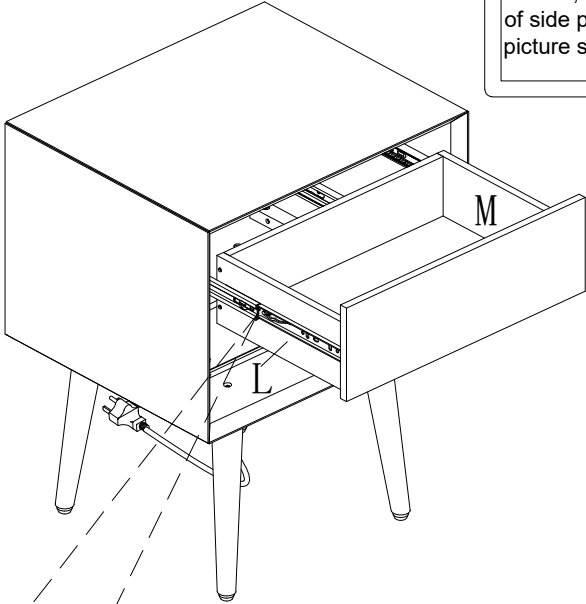

Schematic diagram of slide rail disassembly

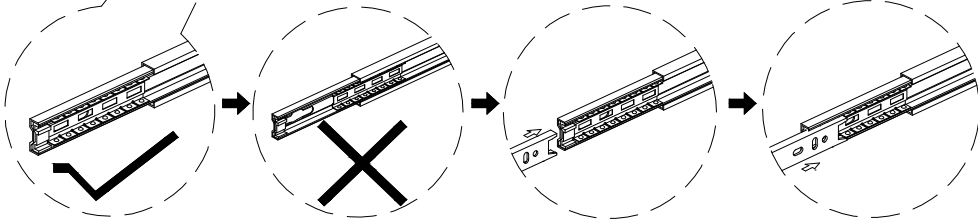

ASSEMBLY INSTRUCTIONS

STEP-14

!
Attention: When installing the drawer, slide the steel ball slide rail of side panel to the most front as picture show.

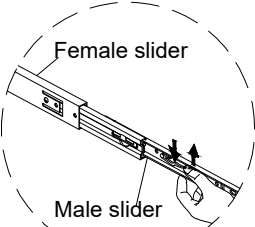
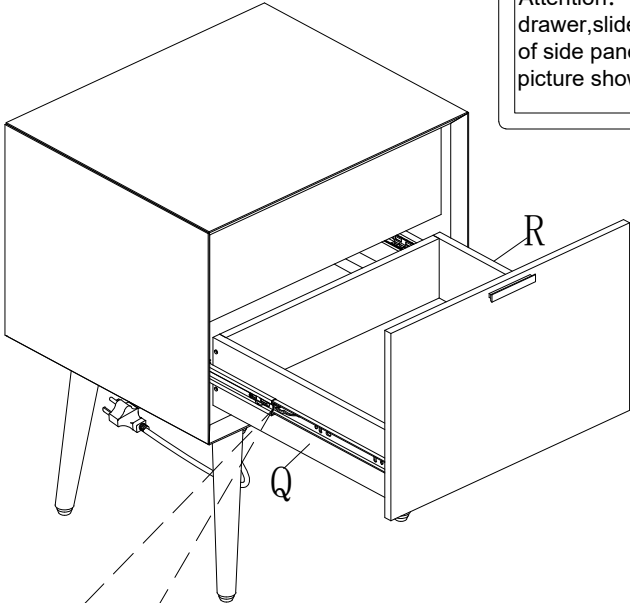

Schematic diagram of slide rail disassembly

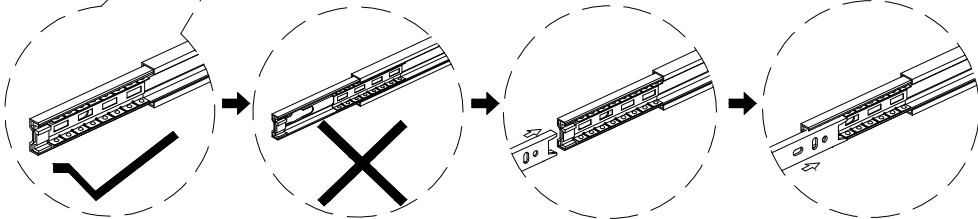

ASSEMBLY INSTRUCTIONS

STEP-15

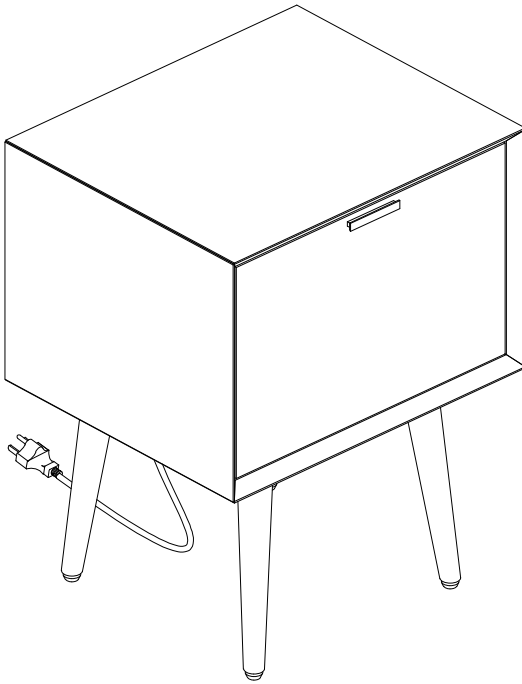

Assembly completed.

WARRANTY

1. We strive to offer high-quality products, and we also try our best to satisfy each and every customer that orders from us with product or service as needed.
2. We provide 30 days warranty starting from the time you receive the item. Each customer must provide a record of their order such as the order number, or item receipt for any items that are out of the warranty period you may also still receive.
3. Replacement parts by purchasing them with our company if they are available.

Are you having difficulty
With assembly? Missing parts?
Please send email with your order No to
customerservice@hulalahome.com
For return, please check the return policy with
the retailer or market place you bought from.

Appreciate your purchasing from us.
Pop up your life by our furniture piece!