

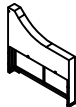





ASSEMBLY INSTRUCTION

OCLJ0427

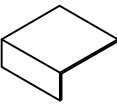
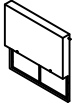
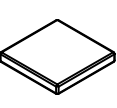
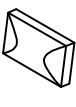
Part list			
NO.	Description	Drawing	Qty
A	Left Armrest		1
B	Right Armrest		1
C	Seat frame		1
D	Backrest		1
E	Seat Cushion		1
F	Back Cushion		1

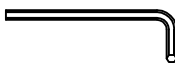
Hardware list Ax2			
NO.	Drawing	Specification	Qty
1		M6*40mm	14
2		M6*1mm	14
3		ALen Key	1

Extra Parts			
NO.	Drawing	Specification	Qty
1		M6*40mm	1
2		M6*1mm	1

STEP 1 Place armrest A side down on clean padded surface, carefully align back D with left armrest A, make sure pin on back properly inserted to pin hole on armrest, use bolt #1, flat washer #2, allen key #3 to connect armrest A with backrest D, please don't fasten any bolt until end of step 3.

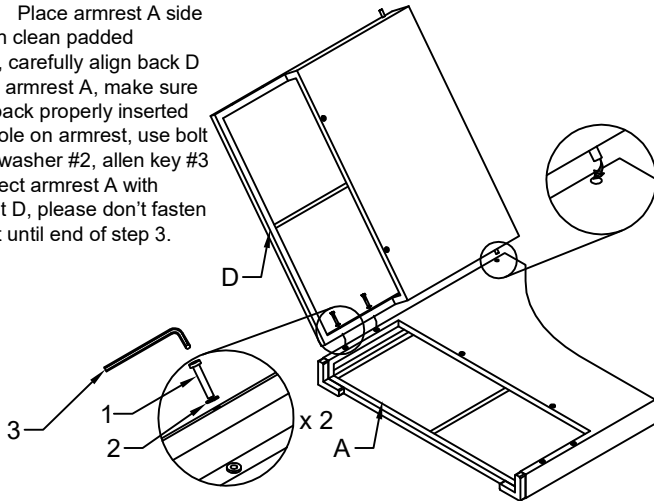

STEP 2 Use bolt #1, flat washer #2, allen key #3 to connect seatframe C with backrest D and armrest A, please don't fasten any bolt until end of step 3.

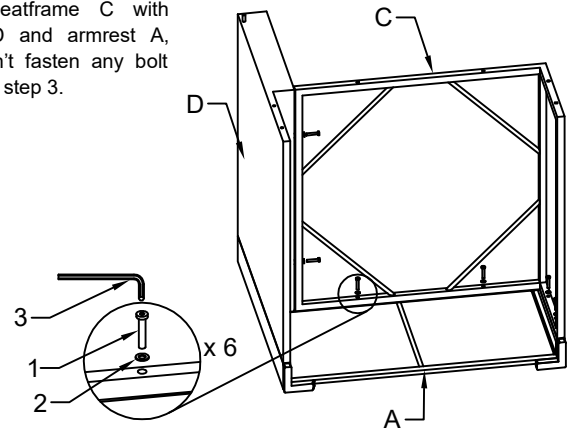

STEP 3 Repeat step 1 to connect right armrest B, seat frame C, backrest D. Make sure edge of armrest/ seat frame/ backrest aligned properly then fasten all bolts to secure and turn the whole unit upright.

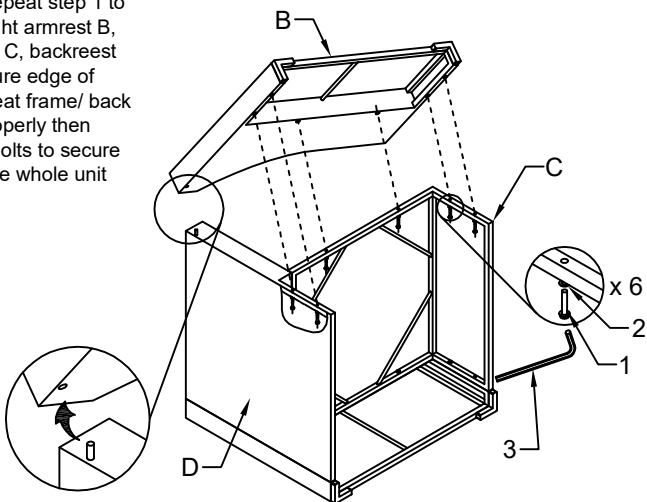



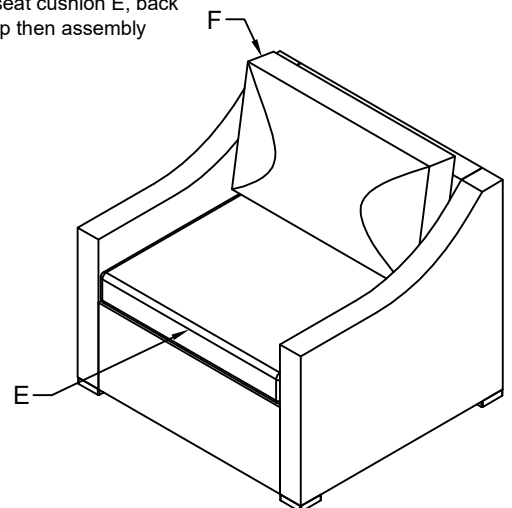



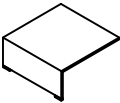

STEP 4 Place seat cushion E, back cushion F on top then assembly completed.



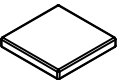

ASSEMBLY INSTRUCTION

OCLJ0427

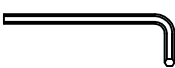
Part list			
NO.	Description	Drawing	Qty
L	Seat frame		1
M	Backrest		1
I	Left side plate		1
W	Right side plate		1
E	Seat Cushion		1
F	Back Cushion		1

Hardware list			Ax2
NO.	Drawing	Specification	Qty
1		M6*40mm	14
2		M6*1mm	14
3		ALen Key	1

Extra Parts			
NO.	Drawing	Specification	Qty
1		M6*40mm	1
2		M6*1mm	1

STEP 1 Place backrest M side down on clean padded surface. Use bolt #1, flat washer #2, allen key #3 to connect seatframe L with backrest M, please don't fasten any bolt until end of step 3.

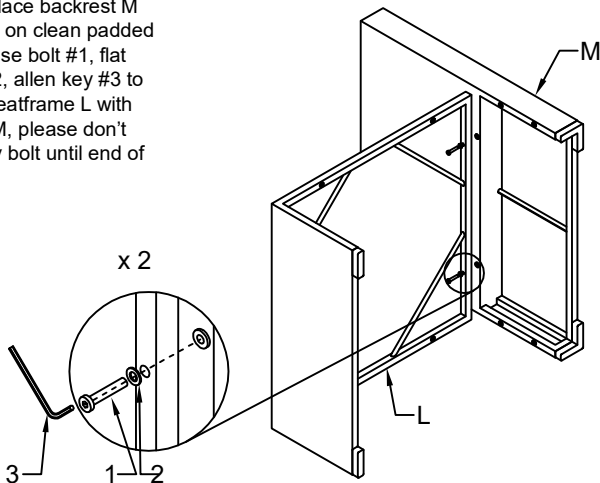

STEP 2 Use bolt #1, flat washer #2, allen key #3 to connect left side plate I with seat frame L and backrest M, please don't fasten any bolt until end of step 3.

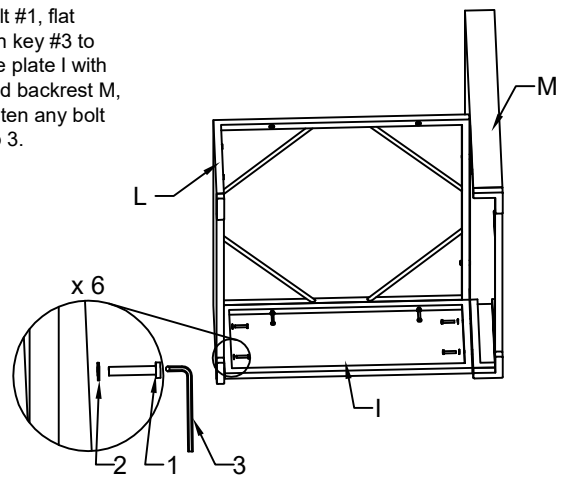

STEP 3 Use bolt #1, flat washer #2, allen key #3 to connect right side plate W with seat frame L and backrest M. Make sure edge of backrest, side plate, seat frame aligned properly then fasten all bolts to secure and turn the whole unit upright.

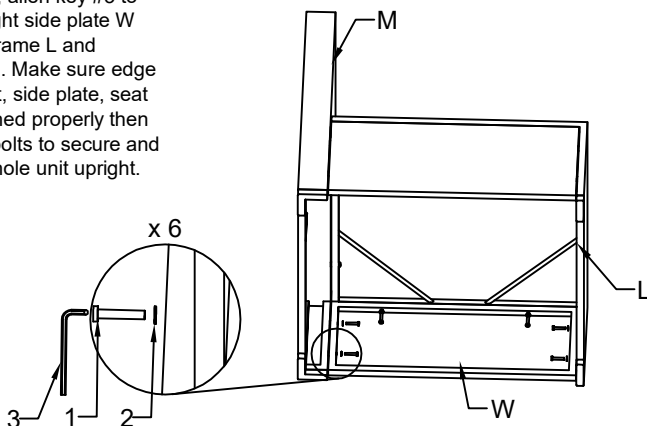



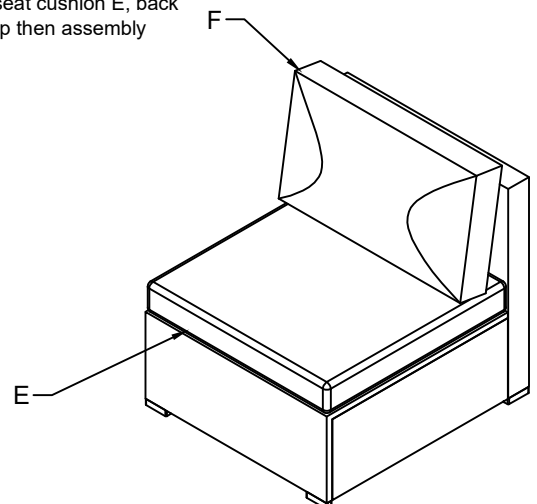



STEP 4 Place seat cushion E, back cushion F on top then assembly completed.

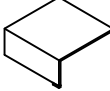

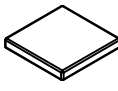

ASSEMBLY INSTRUCTION

OCLJ0427

Part list			
NO.	Description	Drawing	Qty
B	Right Armrest		1
J	Seat frame		1
K	Backrest		1
W	Right side plate		1
E	Seat Cushion		1
F	Back Cushion		1

Hardware list Ax2			
NO.	Drawing	Specification	Qty
1		M6*40mm	14
2		M6*1mm	14
3		ALen Key	1

Extra Parts			
NO.	Drawing	Specification	Qty
1		M6*40mm	1
2		M6*1mm	1

STEP 1 Place armrest A side down on clean padded surface, carefully align back H with right armrest B, make sure pin on back properly inserted to pin hole on armrest, use bolt #1, flat washer #2 allen key #3 to connect armrest B with backrest H, please don't fasten any bolt until end of step 3.

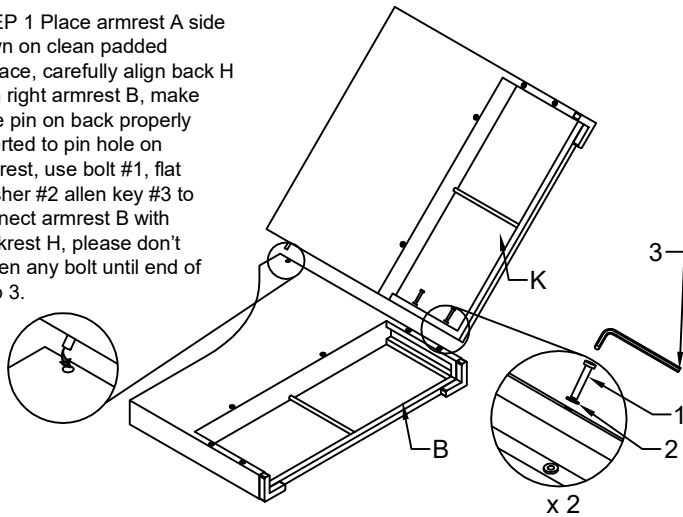

STEP 2 Use bolt #1, flat washer #2, allen key #3 to connect seatframe J with backrest K and armrest B, please don't fasten any bolt until end of step 3.

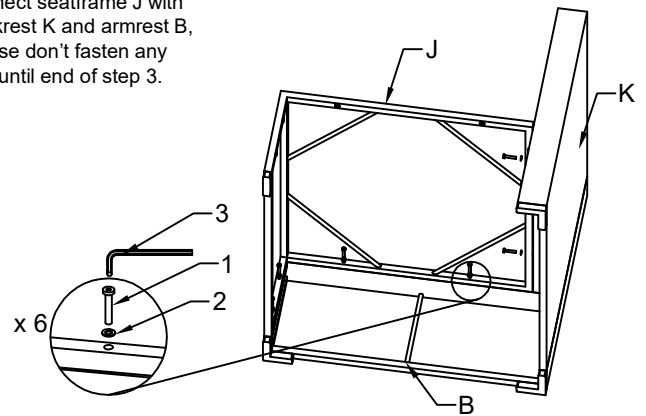

STEP 3 Make sure edge of armrest/ seat frame/ back aligned properly then fasten all bolts to secure and turn the whole unit upright.

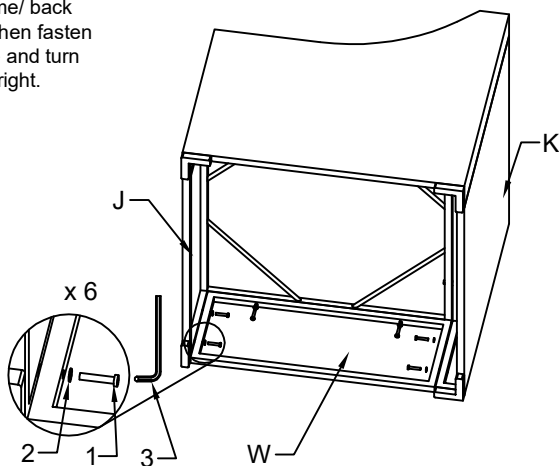

STEP 4 Place seat cushion E, back cushion F on top then assembly completed.

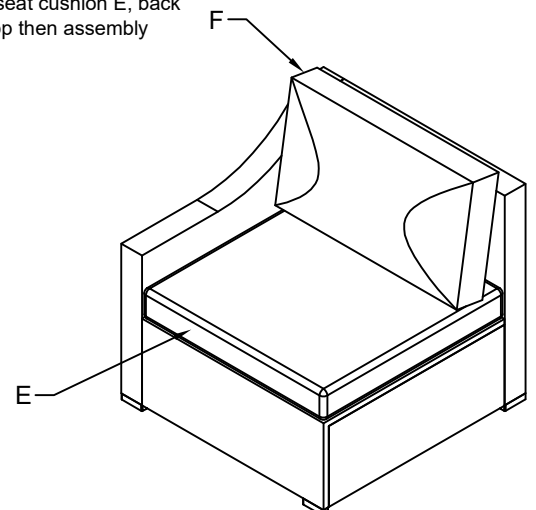

ASSEMBLY INSTRUCTION

OCLJ0427

Part list			
NO.	Description	Drawing	Qty
A	Left Armrest		1
G	Seat frame		1
H	Backrest		1
I	Left side plate		1
E	Seat Cushion		1
F	Back Cushion		1

Hardware list			Ax2
NO.	Drawing	Specification	Qty
1		M6*40mm	14
2		M6*1mm	14
3		ALen Key	1

Extra Parts			
NO.	Drawing	Specification	Qty
1		M6*40mm	1
2		M6*1mm	1

STEP 1 Place armrest A side down on clean padded surface, carefully align back H with left armrest A, make sure pin on back properly inserted to pin hole on armrest, use bolt #1, flat washer #2 allen key #3 to connect armrest A with backrest H, please don't fasten any bolt until end of step 3.

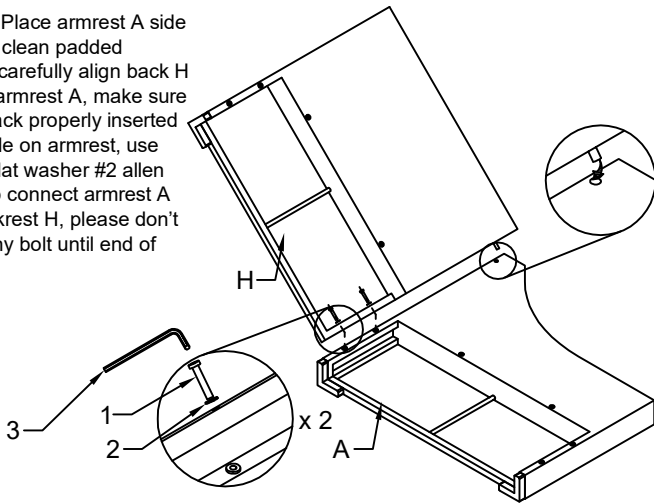

STEP 2 Use bolt #1, flat washer #2, allen key #3 to connect seatframe G with backrest H and armrest A, please don't fasten any bolt until end of step 3.

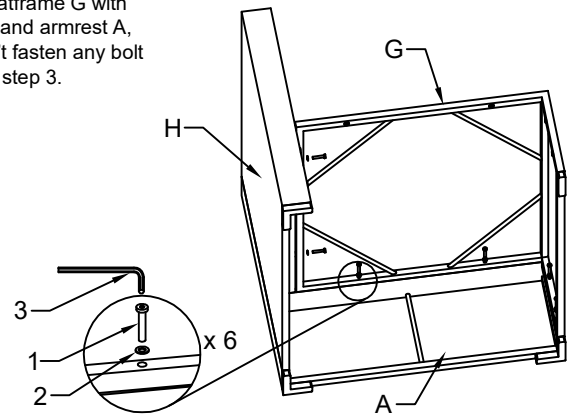

STEP 3 Make sure edge of armrest/ seat frame/ back aligned properly then fasten all bolts to secure and turn the whole unit upright.

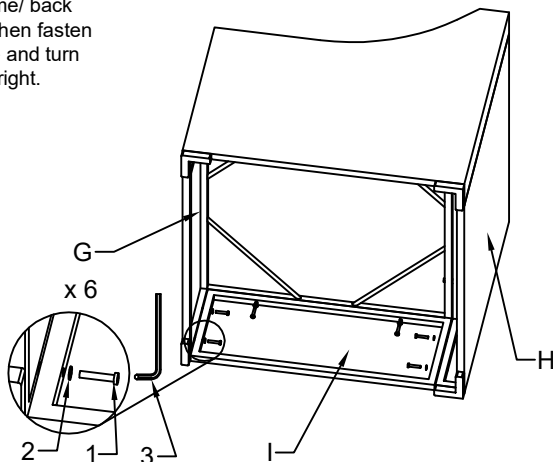

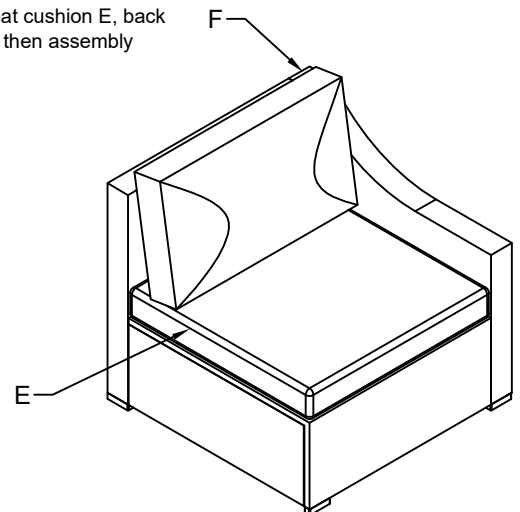

STEP 4 Place seat cushion E, back cushion F on top then assembly completed.



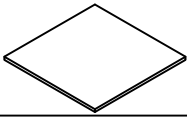
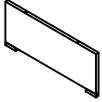
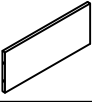
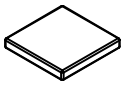

ASSEMBLY INSTRUCTION

OCLJ0427

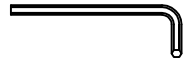
Part list			
NO.	Description	Drawing	Qty
N	Seat frame		1
O	Long side plate		2
P	Short side plate		2
E	Seat Cushion		1

Hardware list Bx2			
NO.	Drawing	Specification	Qty
1		M6*35mm	12
2		M6*1mm	12
3		ALen Key	1

Extra Parts			
NO.	Drawing	Specification	Qty
1		M6*35mm	1
2		M6*1mm	1

STEP 1 Place seat frame N up side down on clean padded surface. Use bolt #1, flat washer #2, allen key #3 to connect seat frame N with long side plate O, please don't fasten any bolt until end of step 3.

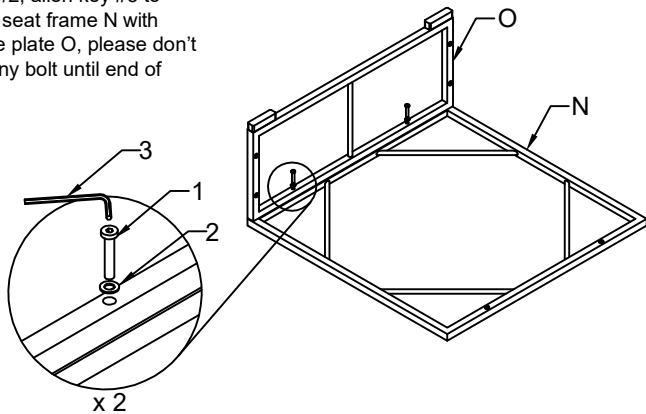

STEP 2 Use bolt #1, flat washer #2, allen key #3 to connect long side plate O with short short side plate P, please don't fasten any bolt until end of step 3.

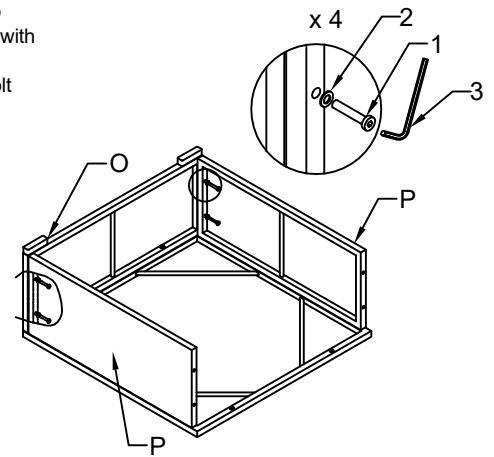

STEP 3 Repeat step 2 to connect short side plate P with another long side plate O, then use bolt #1, flat washer #2, allen key #3 to connect the whole frame with seat frame N. Make sure edge of side plate align with seat frame then fasten all bolts to secure and turn the whole unit upright.

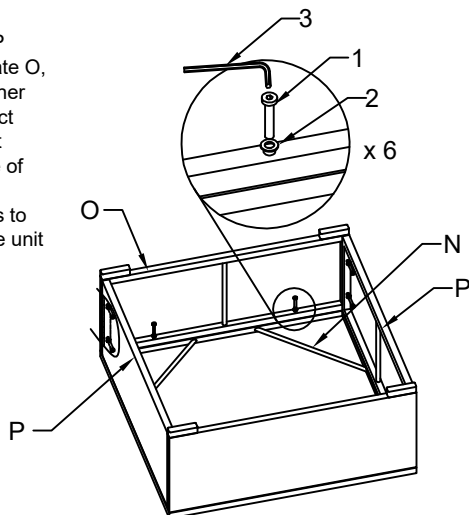



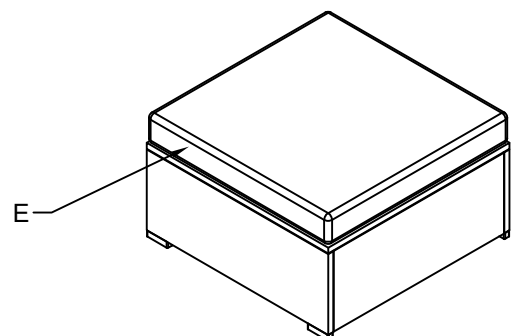



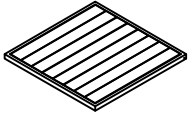

STEP 4 Place seat cushion E on top then assembly completed.

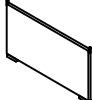
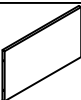
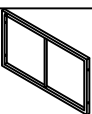
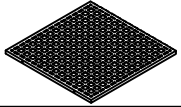
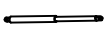



ASSEMBLY INSTRUCTION

OCLJ0427

Part list			
NO.	Description	Drawing	Qty
Q	Top		1
R	Long side plate A		1
S	Long side plate B		1
T	Left side plate		1
X	Right side plate		1
U	Bottom plate		1
V	Gas spring		1

Hardware list			Cx2
NO.	Drawing	Specification	Qty
1		M6*35mm	12
2		M6*1mm	16
3		ALen Key	1
4		M6*20mm	4
5		Plastic Spacer	4

Extra Parts			
NO.	Drawing	Specification	Qty
1		M6*35mm	1
2		M6*1mm	1

STEP 1 Place Bottom plate U on clean padded surface, Use bolt #1, flat washer #2, allen key #3 to connect long side plate T/X with bottom plate U, please don't fasten any bolt until end of step 3.

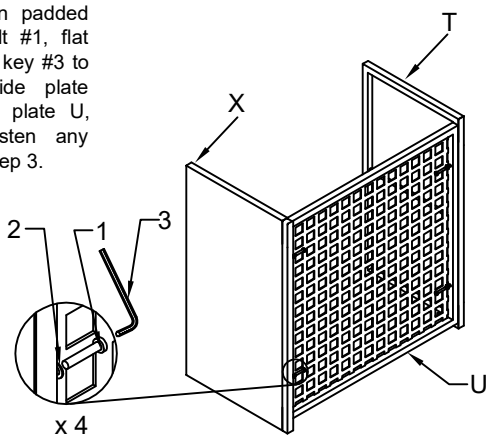

STEP 2 Use bolt #1, flat washer #2, allen key #3 to connect long side plate R/S with side plate R/S, please don't fasten any bolt until end of step 3.

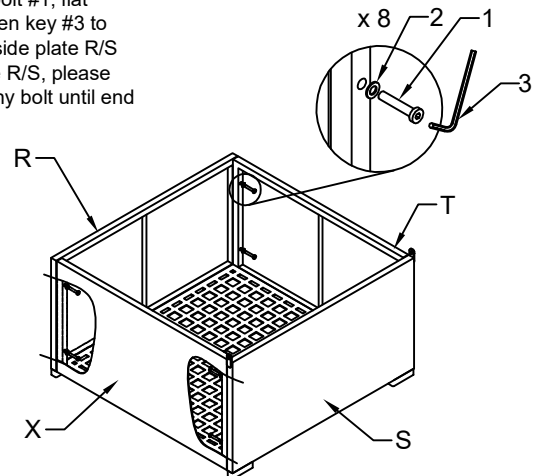

STEP 3 Use bolt #4, flat washer #5, allen key #3 to connect top Q with long side plate S, then use bolt #4, flat washer #2, plastic spacer #5, allen key #3, gas spring V to connect top Q with short side plate T. Make sure edge of top/side plates align properly then fasten all bolts to secure.

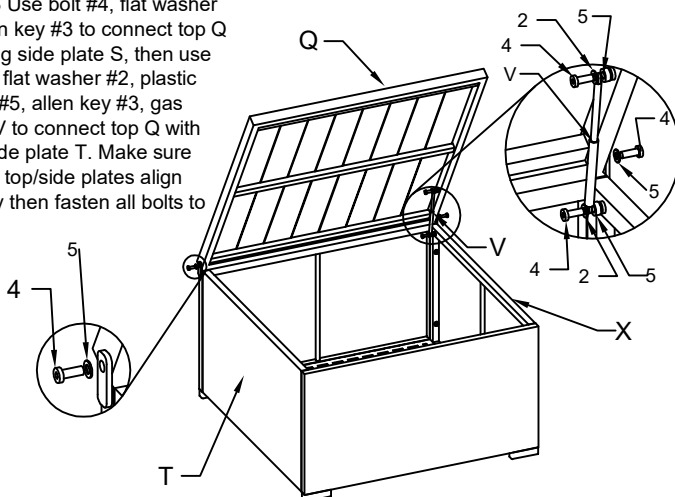

STEP 3 Press the table top to keep it close, then assembly completed.

