

HULALA

H O M E

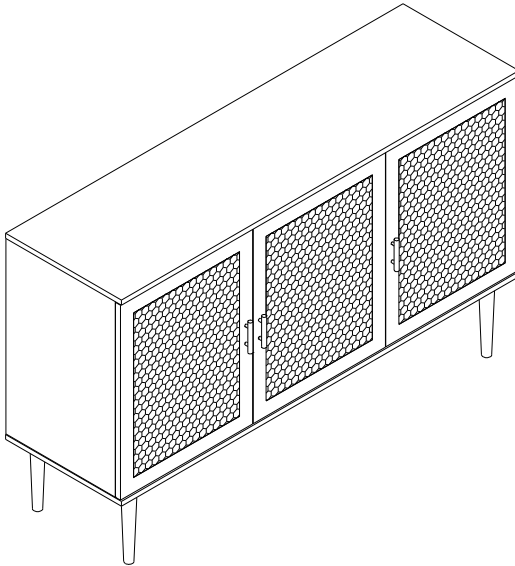

ITEM NO.SCSD0757

NOTE:

This brochure contains IMPORTANT safty info. Please read and keep for future reference.

MAINTAINANCE AND WARNING

- Keep furniture away from heat sources.
- Do not clean furniture with harsh cleaner or polishes. Do not use detergents, Solvents, abrasives, spray packs or leather cleaner. Use non-color mild soap with warm water to clean spills (Mix 1:10 soap to water)
- Do not place furniture under direct sunlight, material will possibly fade over time.
- Do not use on site dry Cleaning machine. Children should not climb or jump on the furniture.
- Do not write on furniture that is not protected by a padded barrier .
- Not for commercial use, only for residential use.



Weight Limitation

80LBS

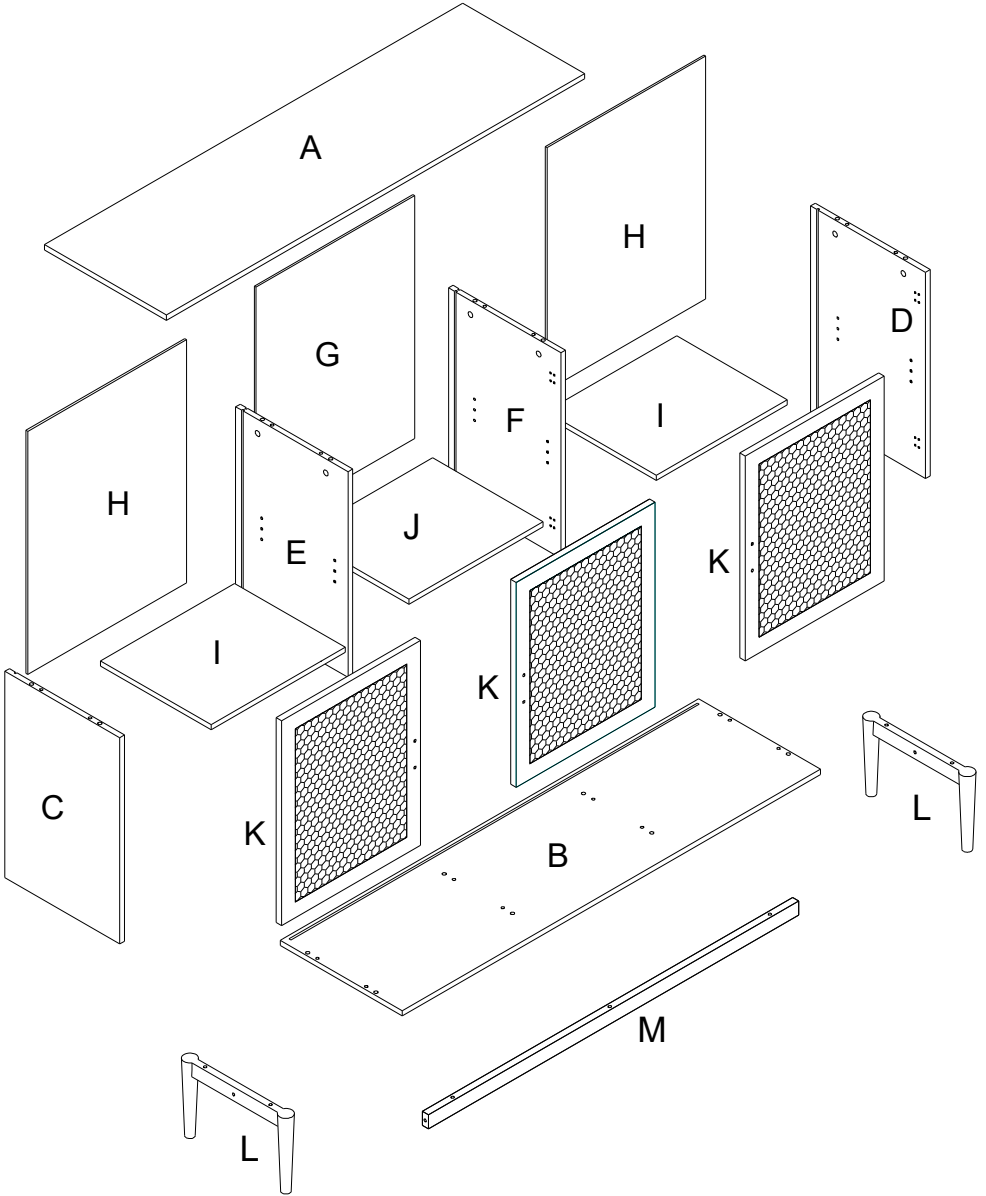

OVERVIEW



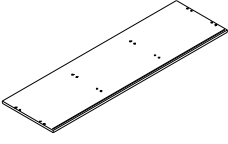
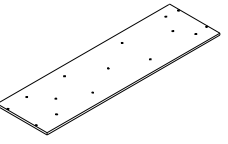
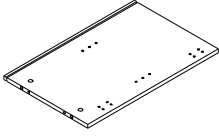
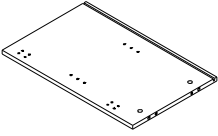
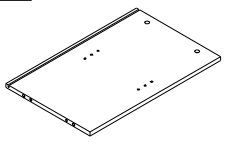
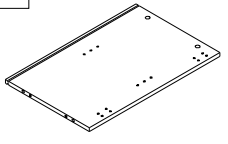
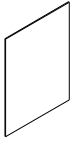
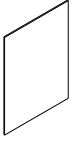
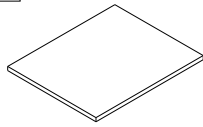
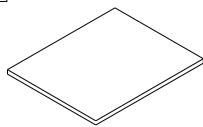
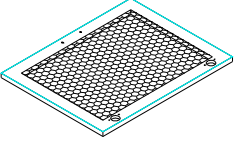
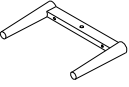
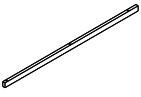



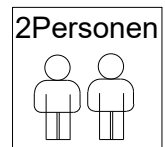

HARDWARE LIST

<p>A</p> 	<p>B</p> 	<p>C</p> 	<p>D</p> 
<p>1 PC</p>	<p>1 PC</p>	<p>1 PC</p>	<p>1 PC</p>
<p>E</p> 	<p>F</p> 	<p>G</p> 	<p>H</p> 
<p>1 PC</p>	<p>1 PC</p>	<p>1 PC</p>	<p>2 PCS</p>
<p>I</p> 	<p>J</p> 	<p>K</p> 	<p>L</p> 
<p>2 PCS</p>	<p>1 PC</p>	<p>3 PCS</p>	<p>2 PCS</p>
<p>M</p> 			
<p>1 PC</p>			







Persons Required For Assembly:



PARTS LIST 1





①	x58	②	x8	③	x16	④	x8	⑤	x4
									
⑥	x8	⑦	x6	⑧	x2	⑨	x7		
									

SPARE

①	x5	②	x1	⑤	x1	⑥	x1	⑦	x1
									
⑧	x1	⑨	x1						
									

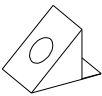
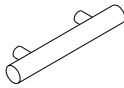
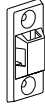

Be sure to inspect all packing material carefully for small parts, that may have come loose inside the carton during shipment.

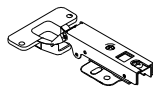
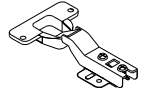
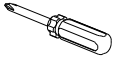
PARTS LIST 2

⑩	x4	⑪	x18	⑫	x3	⑬	x4	⑭	x12
									
⑮	x2	⑯	x1	⑰	x8	⑱	x4	⑲	x2
									
⑳	x1								
									

Be sure to inspect all packing material carefully for small parts, that may have come loose inside the carton during shipment.

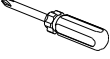

ASSEMBLY INSTRUCTIONS

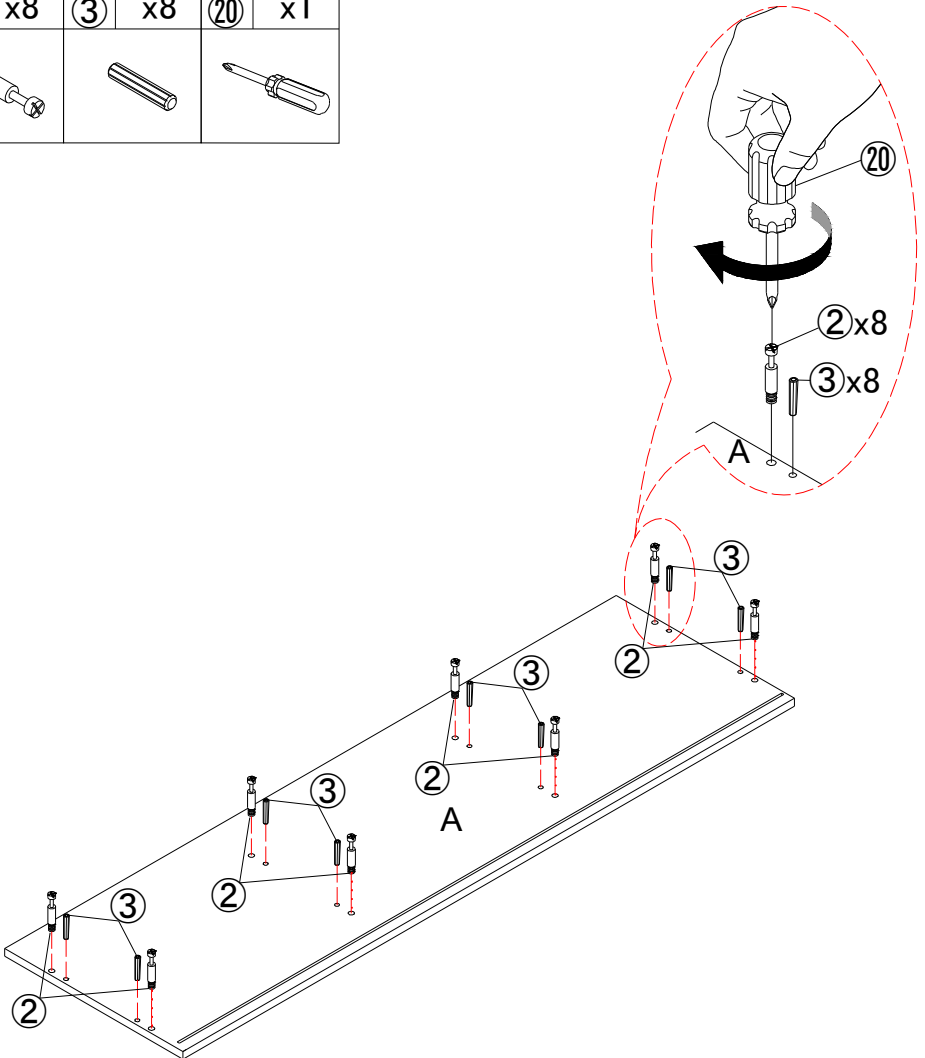
②	x8	③	x8	⑳	x1
					



STEP1:

Prepare for part A. Align the holes in part A, insert wooden dowel ③ by hand, tighten with screwdriver ⑳ tighten ②。

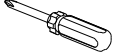
④	x8	⑰	x8	⑳	x1
					

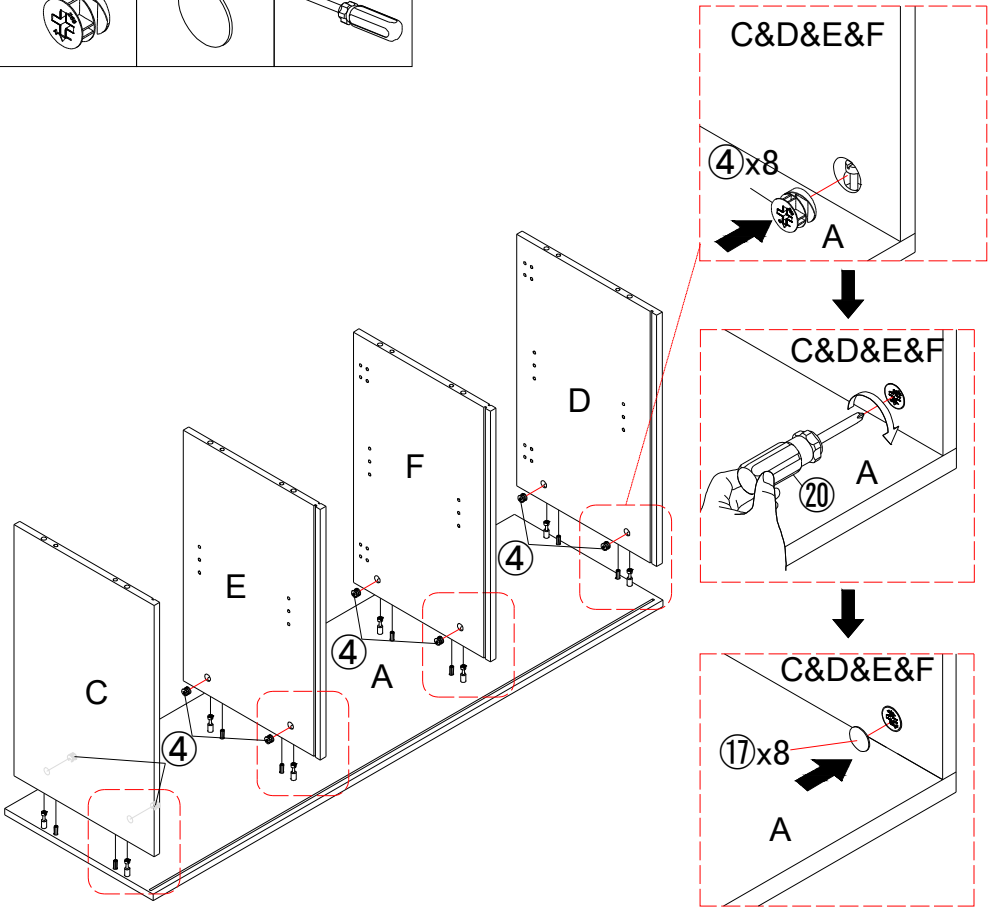

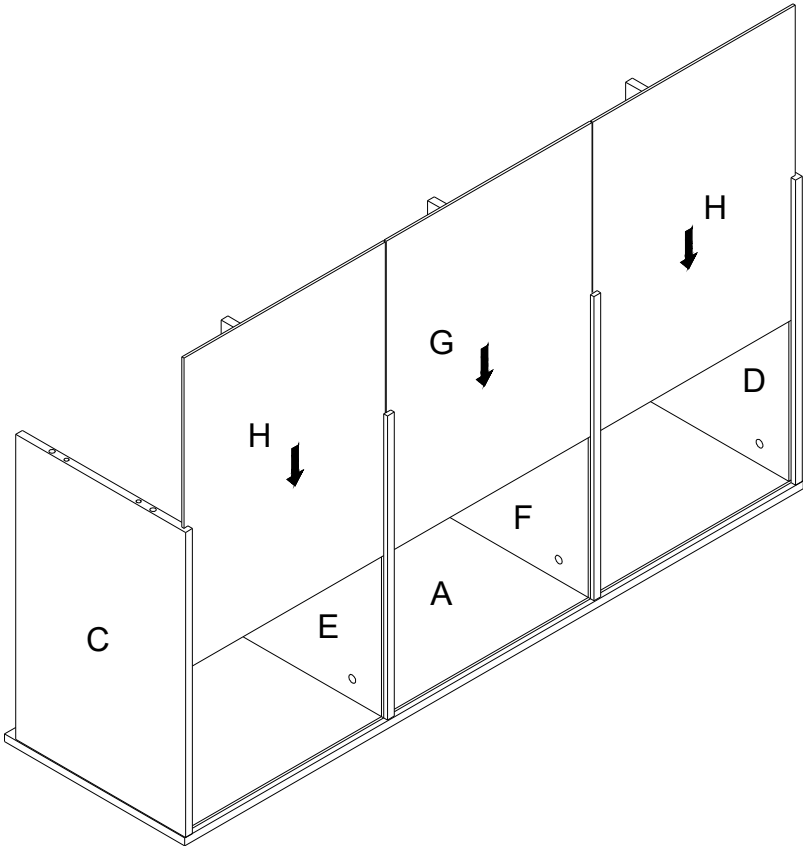

STEP2:

Connect the part A with part C&D&E&F. align the hole in the part C&D&E&F, insert the bolt ② and wooden dowel ③ in part A into part C&D&E&F. insert cam bolt ④ into the corresponding hole of side panel C&D&E&F, and tighten the nuts ④ with a screwdriver ⑳. After installation, cover the screw holes with ⑰. Make sure the groove is in same side as picture show.



STEP3:

slide in the part H,G,H into the groove in part C,E and E,F and F,D . make sure they are also in groove in part A.

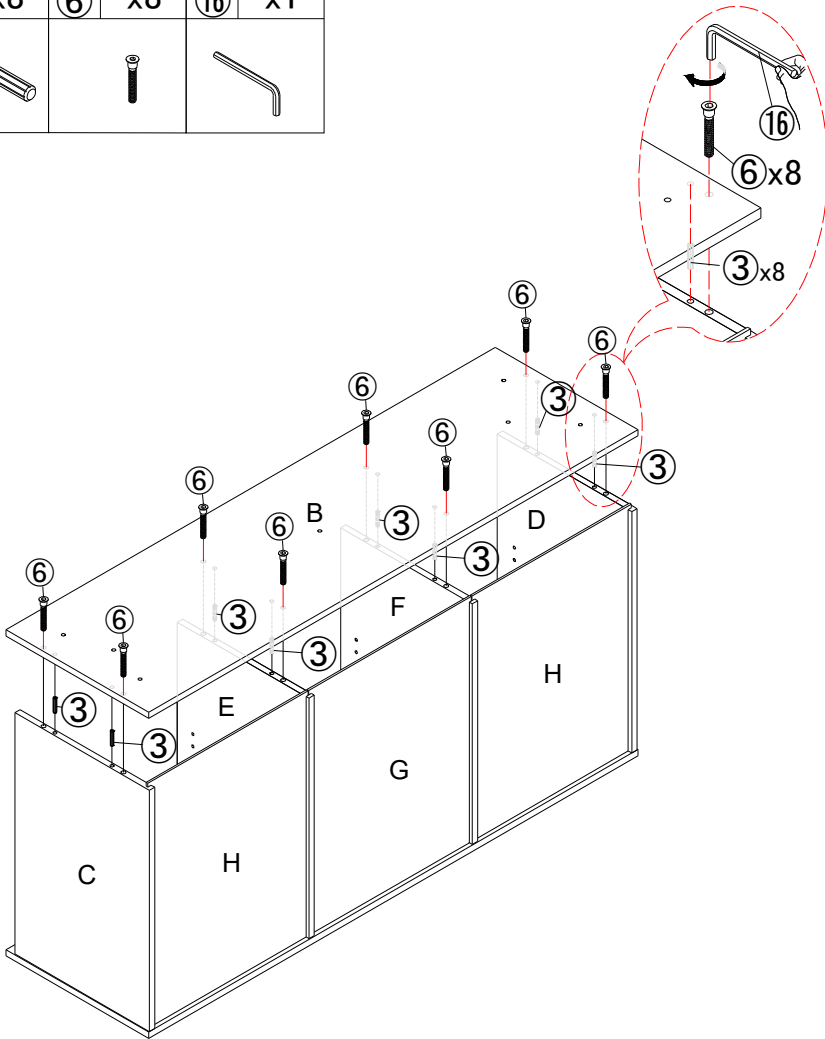

③	x8	⑥	x8	⑯	x1
					



STEP4:

Connect the part B the pre-assembled unit in step 3. Insert the wooden dowel ③ into the part C&D&E&F as the picture show.

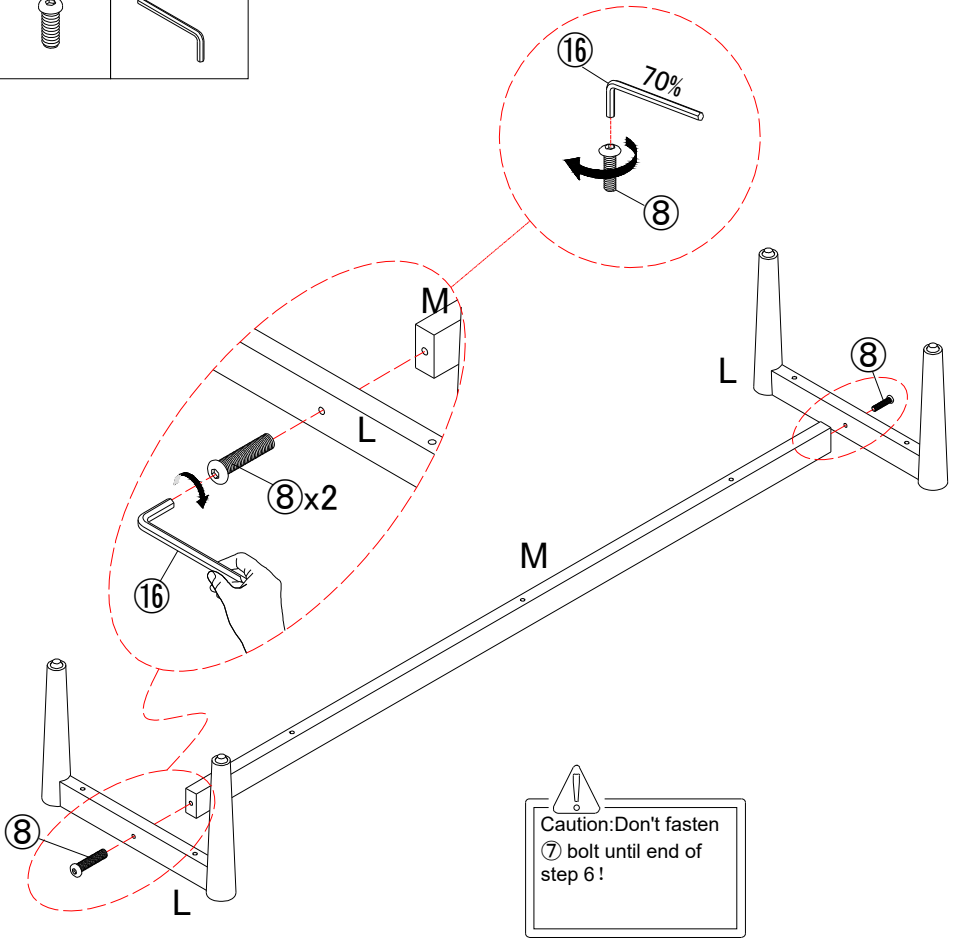

Then align the holes in part B, Insert screw ⑥ and push it down so that it connects to parts C&D&E&F. Next, and tighten the screw ⑥ with an Allen key ⑯.

⑧	x2	⑩	x1
			



STEP5:

Prepare the leg racks. Align the holes of the M part with the holes of the L part, insert the screw ⑧, and tighten the screw ⑧ with the allen key ⑩.

⑨	x7	⑯	x1
			

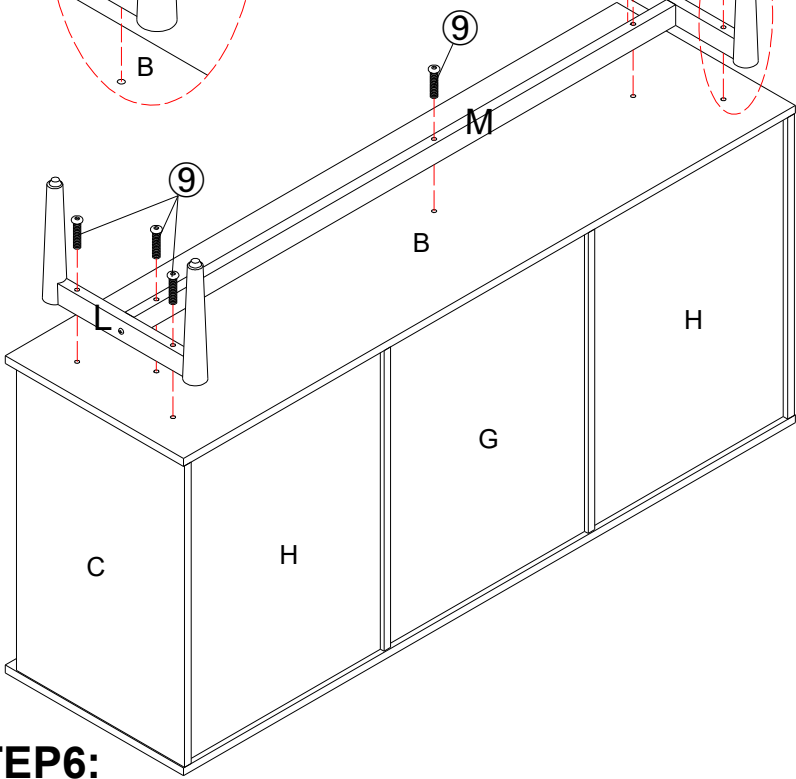
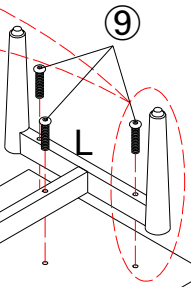
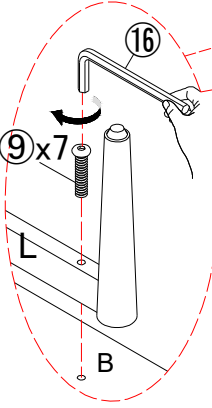
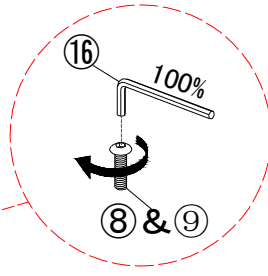

STEP6:

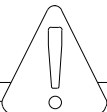

connect the leg frame to the cabinet. Attach the leg frame to the pre-assembled unit in step 4 with a screw ⑨ and tighten ⑨ with a allen key ⑯.

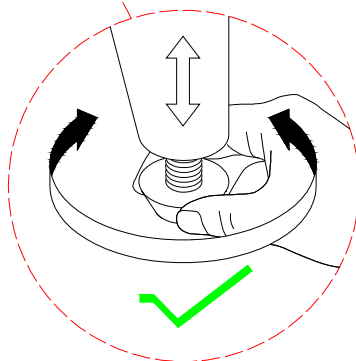
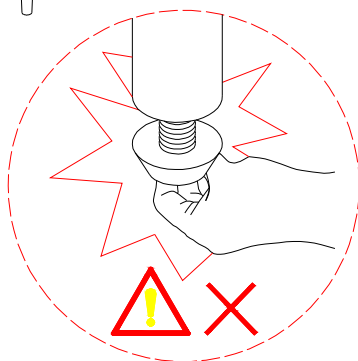
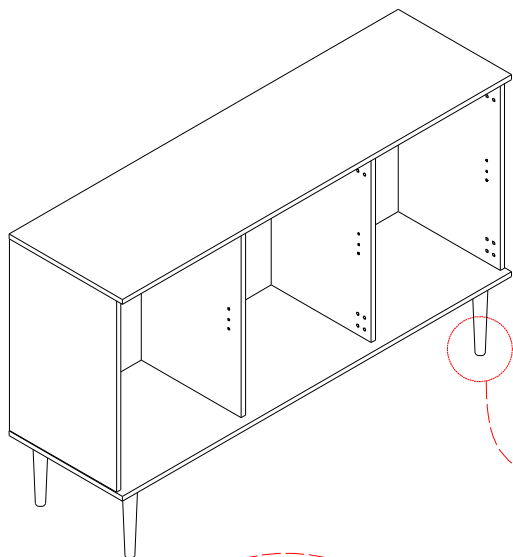

Attention:
Before the next step, adjust
the feet of the locker to keep
it level.

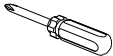

STEP7:

①	x18	⑪	x18	⑳	x1
					

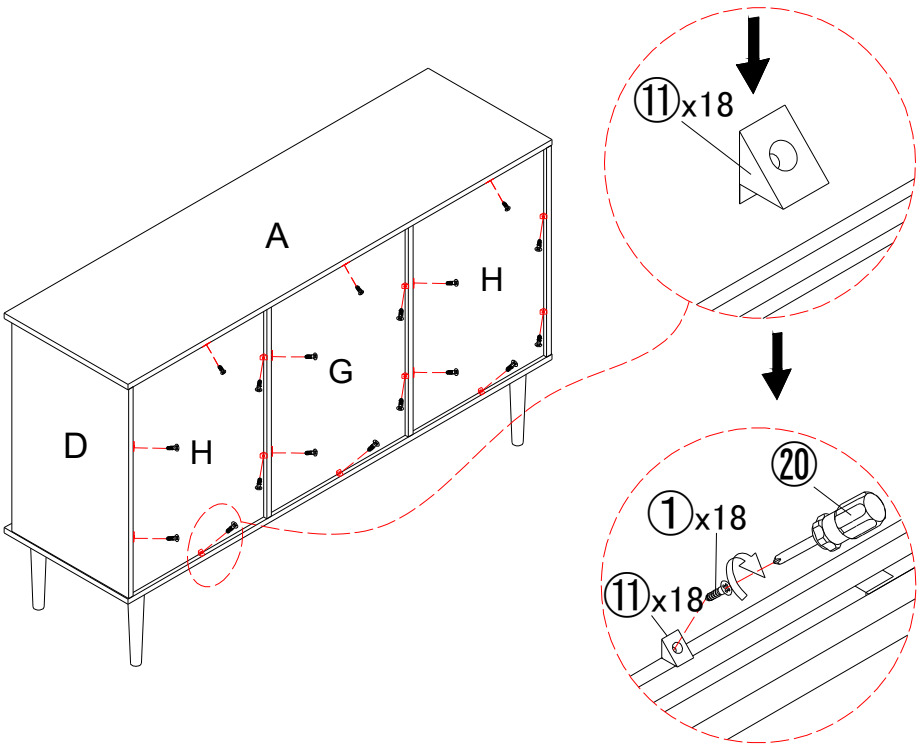

STEP8:

Insert hardware ⑪ into part H&G&H as shown, screw in screw ① using screwdriver ⑳ and tighten fully.

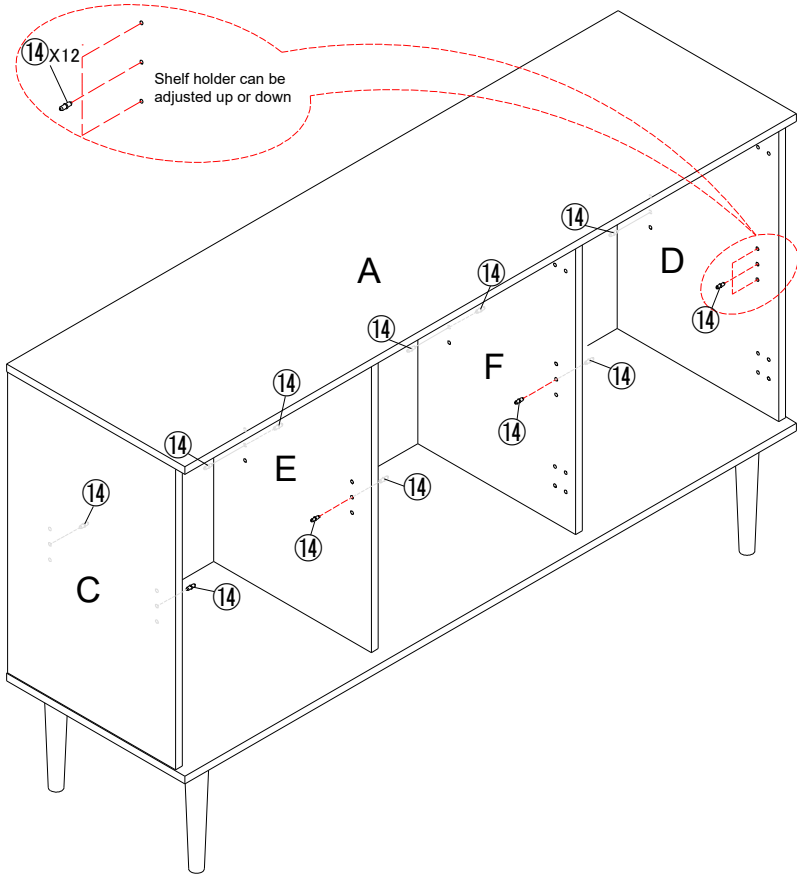
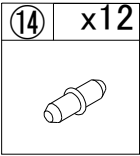

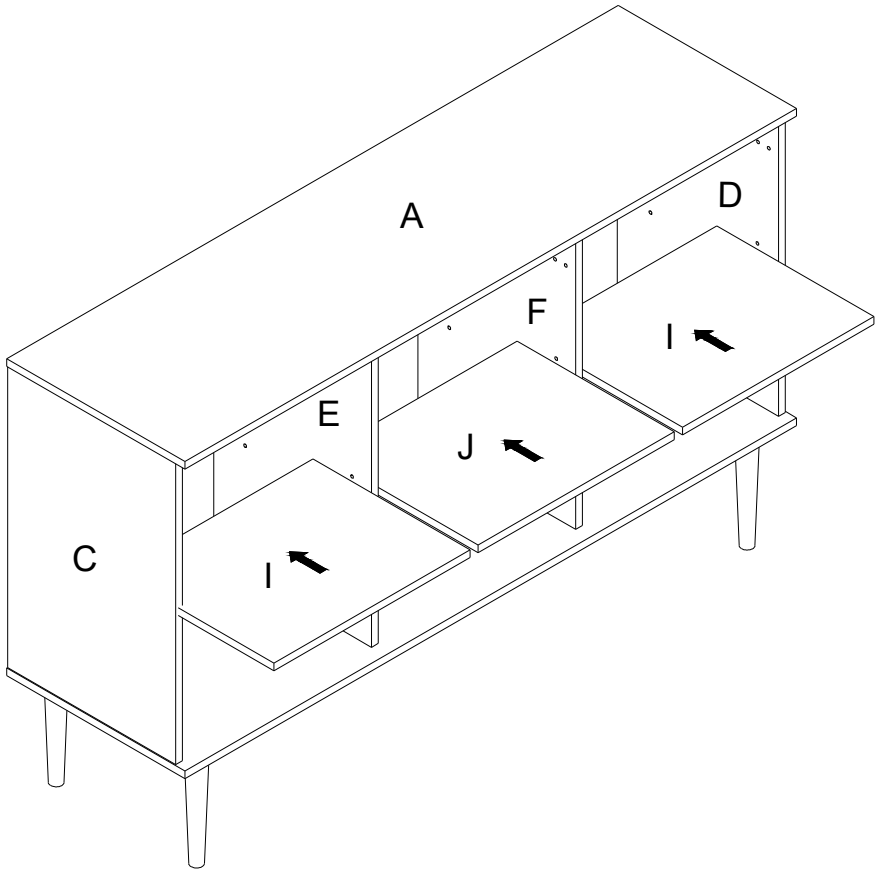

STEP9:

Insert shelf pin ⑭ into pre-assemble unit at step 8.



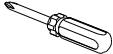

STEP10:
attach adjustable shelf I&J&I to pin ⑭.

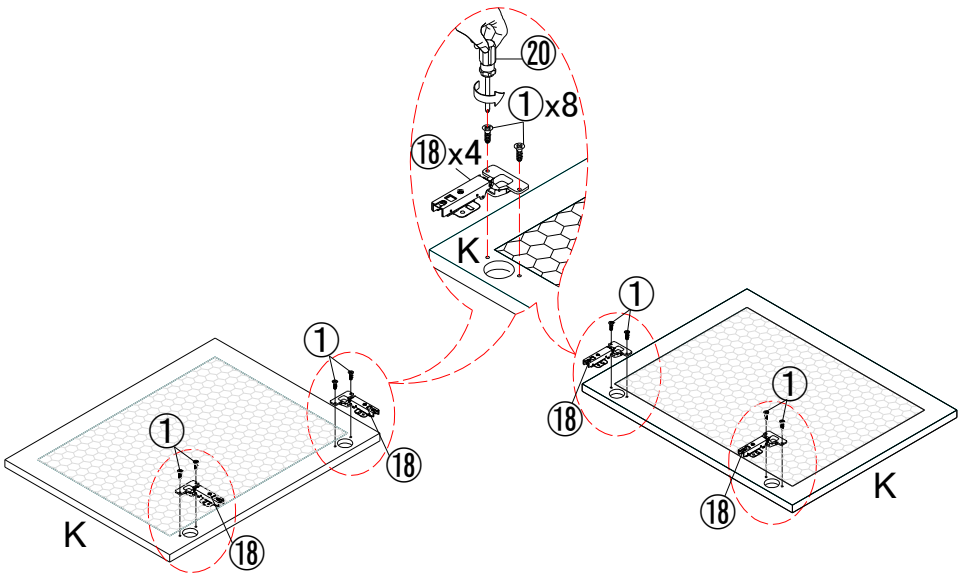
①	x8	⑱	x4	⑳	x1
					

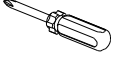

STEP11: Use screw ① to attach the hinges ⑱ to door panel (K), tighten screws ① with screwdriver ⑳.

⑦	x4	⑫	x2	⑳	x1
					

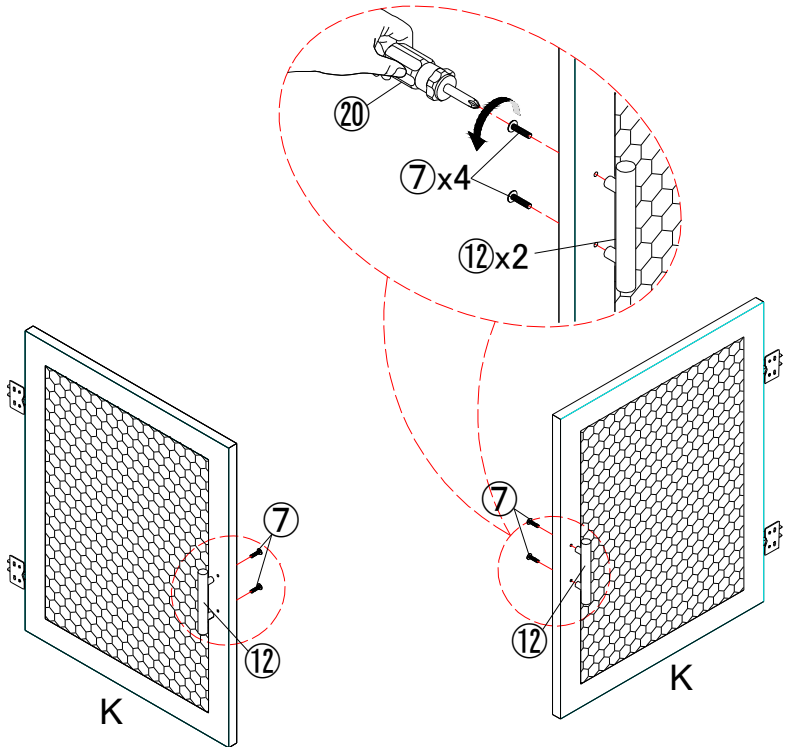



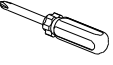

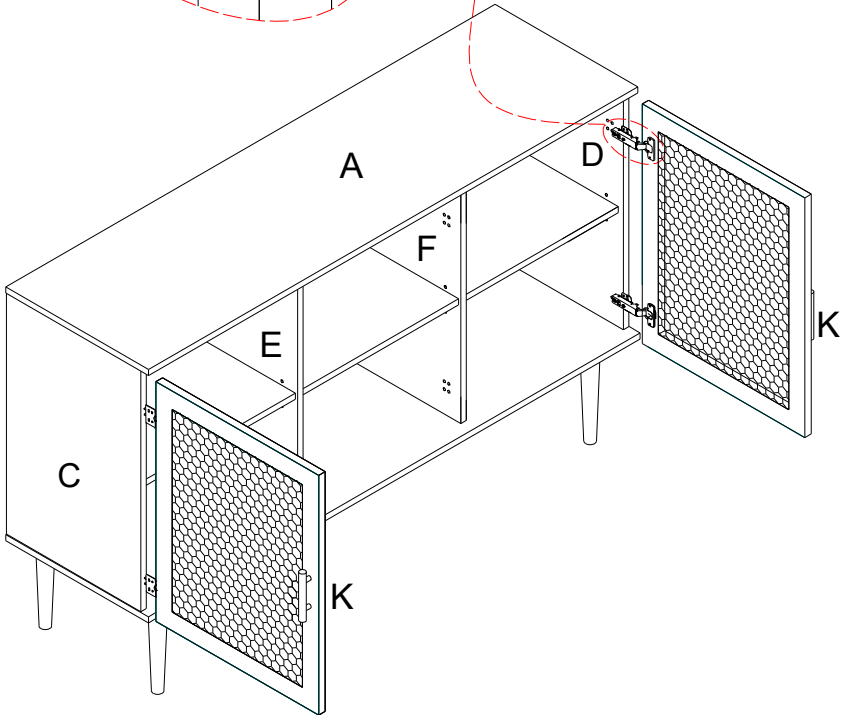
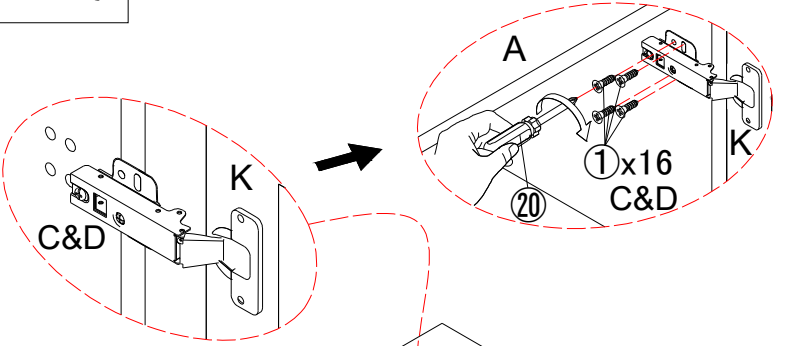
STEP12: Use bolt ⑦ to attach handle ⑫ to door panel (K), tighten bolts ⑦ with screwdriver ⑳.

①	x16	⑳	x1
			



STEP13:

Use screw ① to attach left door (K) and right door (K) to pre-assemble unit at step 10 ,tighten screw ① with screwdriver ⑳ .

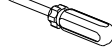
①	x4	⑦	x2	⑫	x1	⑲	x2	⑳	x1
									

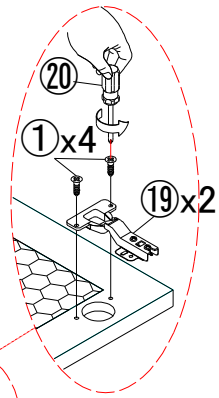

1:

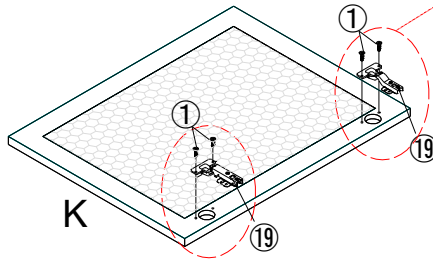

2:

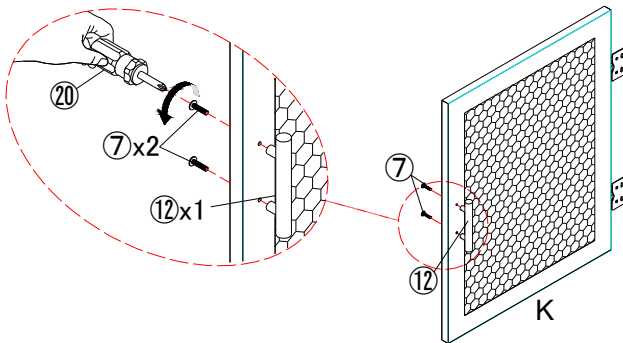

STEP14: Use screw ① to attach the hinges ⑲ to door panel (K), tighten screws ① with screwdriver ⑳.

Use bolt ⑦ to attach handle ⑫ to door panel (K), tighten bolts ⑦ with screwdriver ⑳.

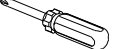
①	x8	⑳	x1
			

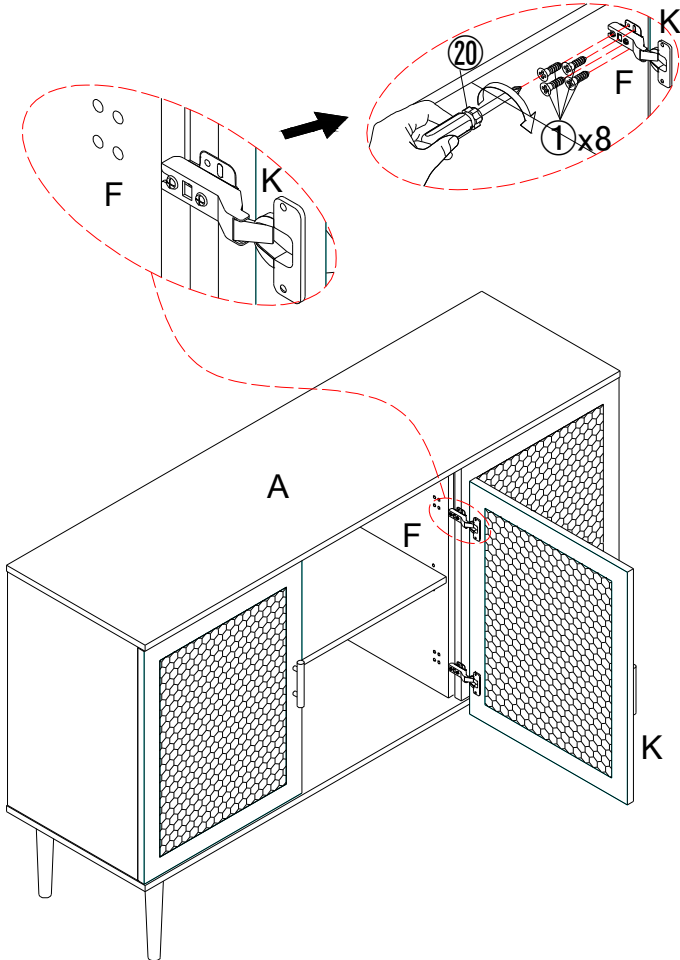

STEP15:

Use screw ① to attach middle door (K) to pre-assembly unit at step 13 ,tighten screw ① with screwdriver ⑳ .

Concealed hinges are three-way adjustable:

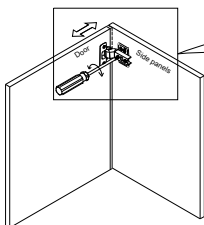

Horizontal
by screw adjustment!

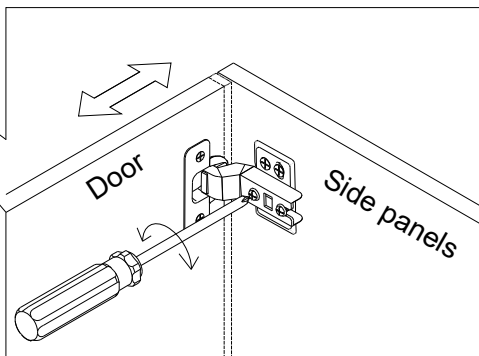

Concealed hinges are three-way adjustable:

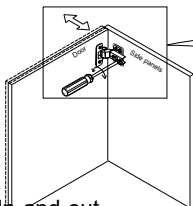

In-and-out
by loosening the hinge arm
mounting screw or via cam
adjustment!

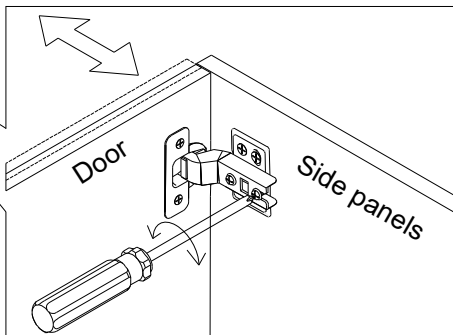

Concealed hinges are three-way adjustable:

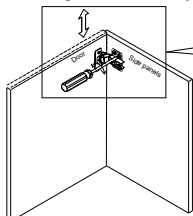

Vertical via slots in
the mounting plate
or via cam adjustment!

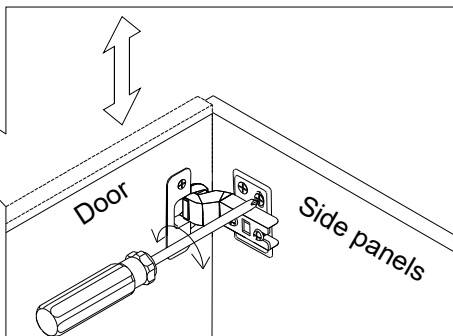



STEP16:



Video for door adjustment

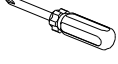

Hinge adjustment method

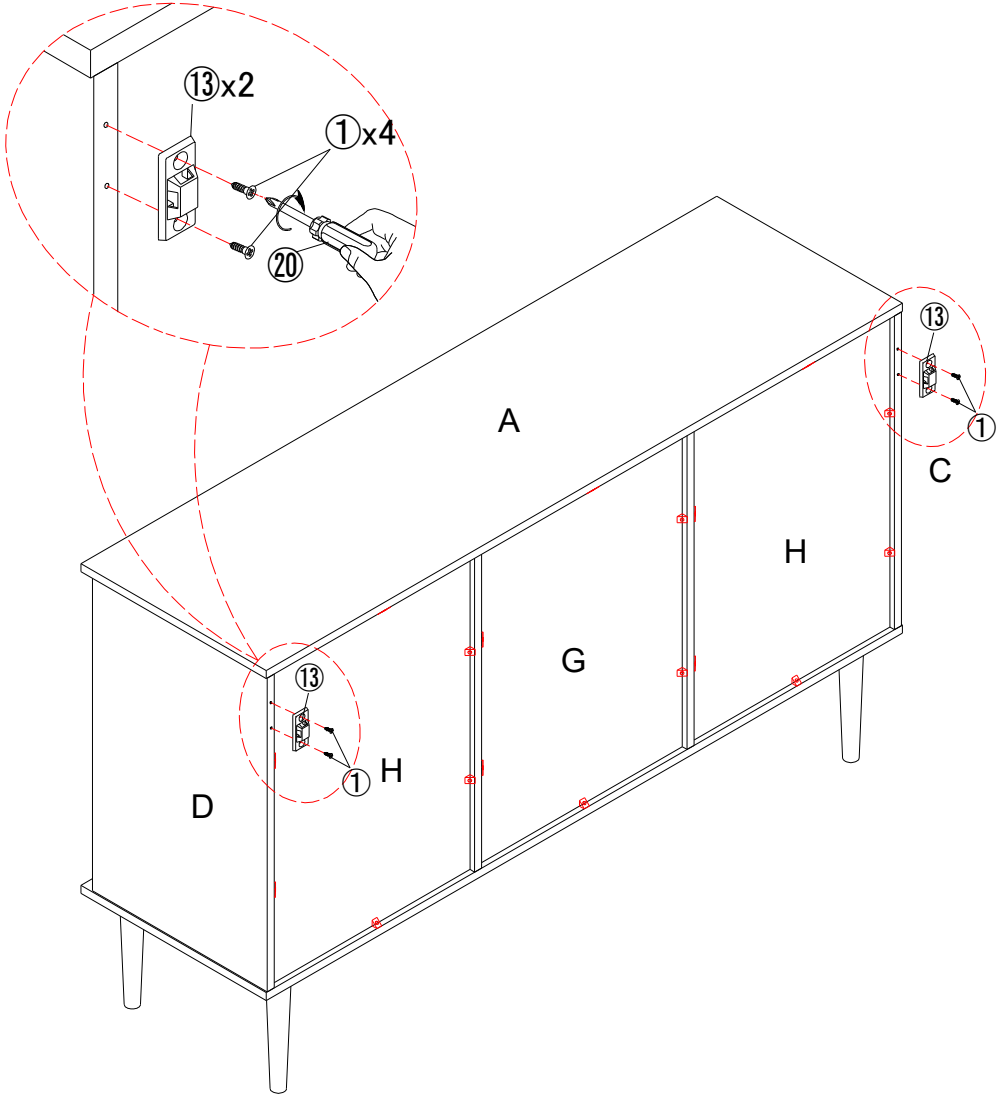
①	x4	⑬	x2	⑳	x1
					



STEP17:

Attach part ⑬ to parts D&C with bolt ① and tighten the bolt ① with screwdriver ⑳.

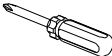
⑤	x4	⑩	x4	⑬	x2	⑳	x1
							

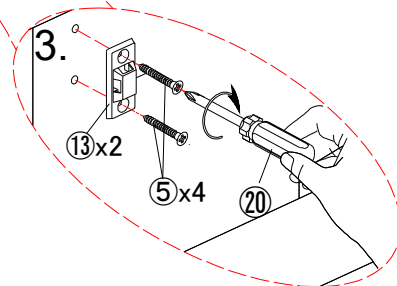
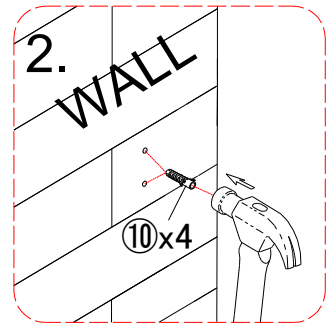
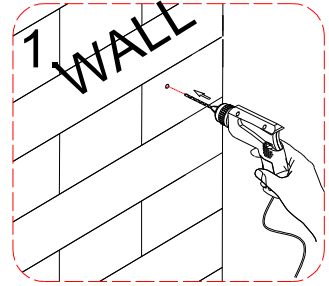
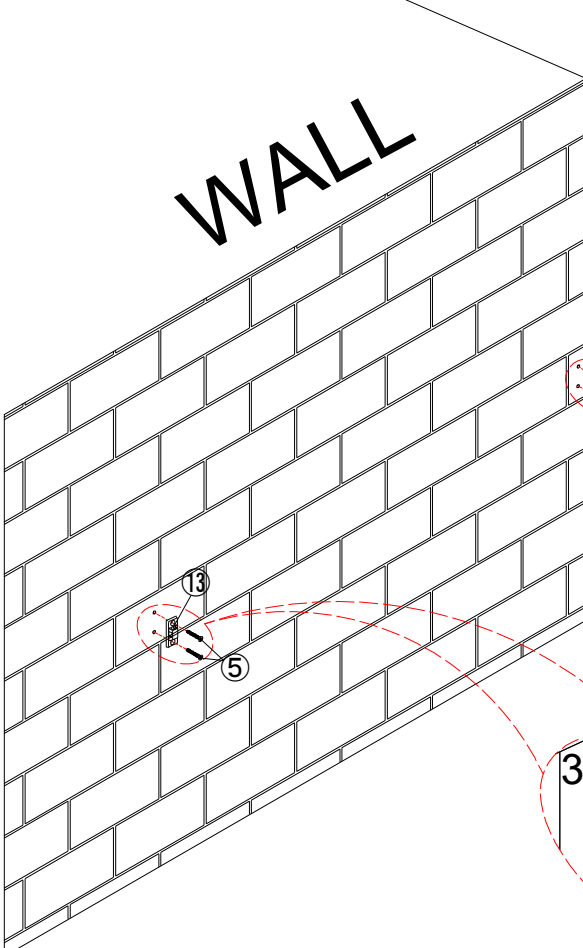

STEP18:

Mark the position on the wall, that corresponds to the location of part ⑬ on the side panel D&C; Drill and insert the expandable screw ⑩ by hammer.

Assemble the part ⑬ to the wall. Align the hole in the part ⑬ with the expandable screw ⑩, use screw ⑤ to attach it and tighten by screwdriver ⑳.

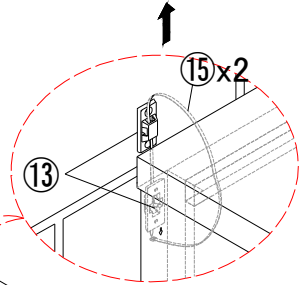
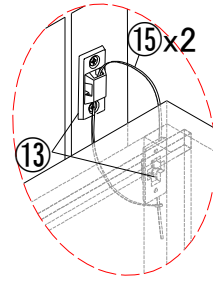
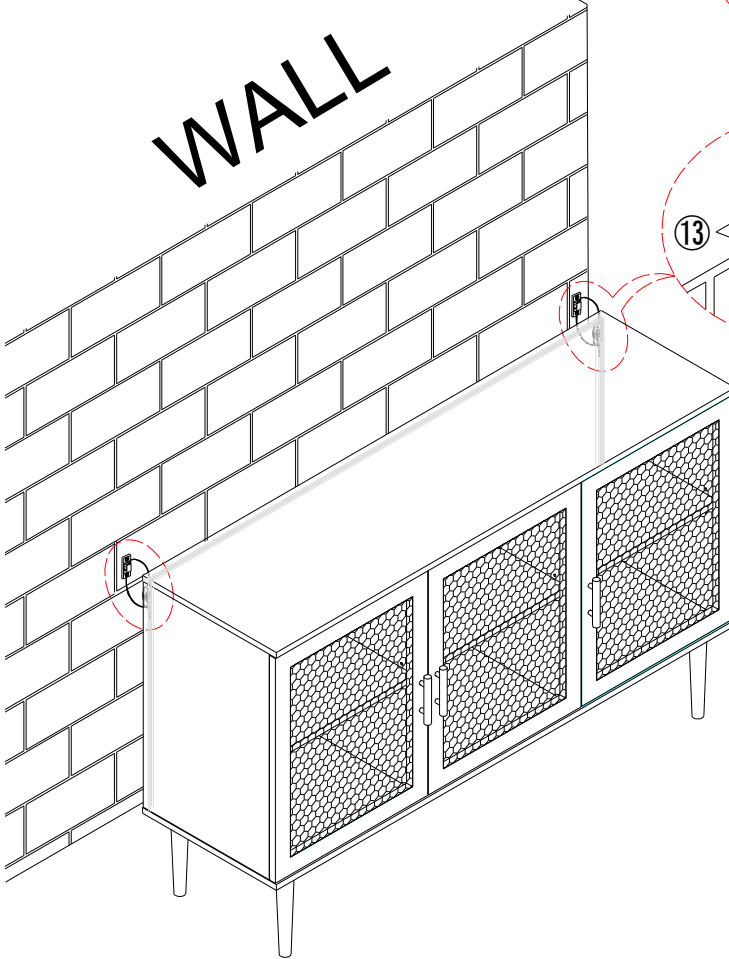
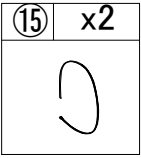

STEP19: Let the plastic belt ⑮ pass through the both part ⑬ and pull tightly.

WARRANTY

We strive to offer high-quality products, and we also try our best to satisfy each and every customer that orders from us with product or service as needed. We provide 30 days warranty starting from the time you receive the item. Each customer must provide a record of their order such as the order number, or item receipt for any items that are out of the warranty period you may also still receive replacement parts by purchasing them with our company if they are available.

Are you having difficulty
with assembly? Missing parts?
Please send email with your order No to
customerservice@hulalahome.com
For return, please check the return policy with
the retailer or market place you bought from.

Appreciate your purchasing from us.
Pop up your life by our furniture piece!