

HULALA

H O M E

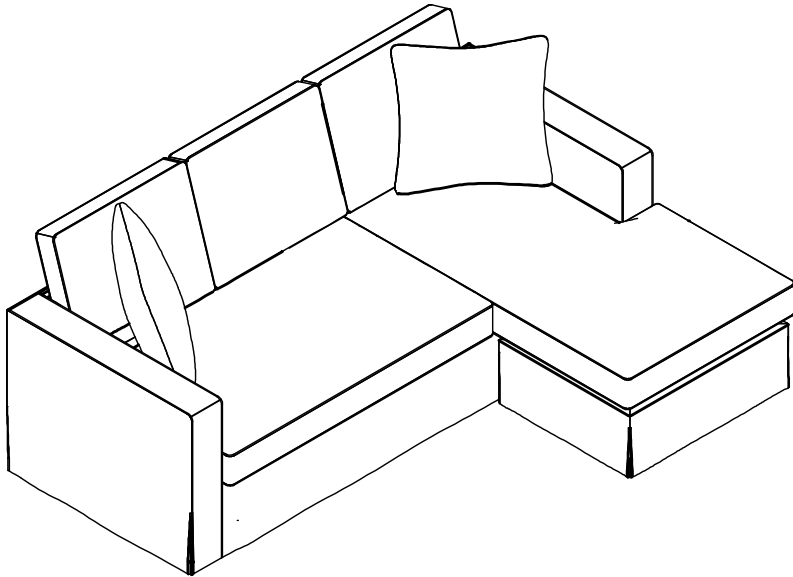

ITEM NO.SFAY1232

NOTE:

This brochure contains IMPORTANT safety info. Please read and keep for future reference.

MAINTAINANCE AND WARNING

- 1.Keep furniture away from heat sources.
- 2.Do not clean furniture with harsh cleaner or polishes.Do not use detergents,solvents,abrasives,spray packs or leather cleaner. Use non-color mild soap with warm water to clean spills(Mix 1:10 soap to water).
- 3.Do not place furniture under direct sunlight,material will possibly fade over time.
- 4.Do not use on site dry cleaning machine.Children should not climb or jump on the furniture.
- 5.Do not write on furniture that is not protected by a padded barrier.
- 6.Not for commercial use,only for residential use.



Weight Limitation
900 LBS

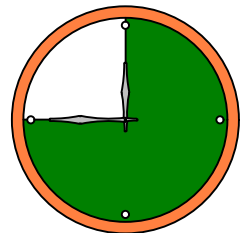

Around **45 min**

PARTS LIST

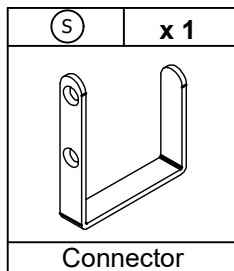
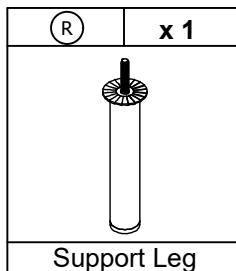
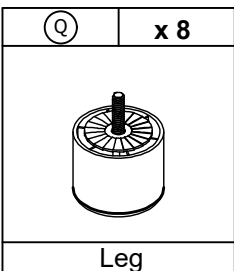
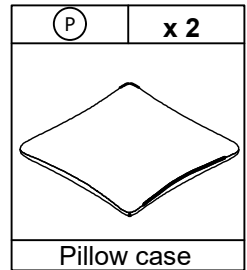
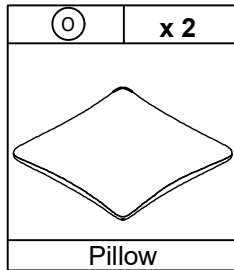
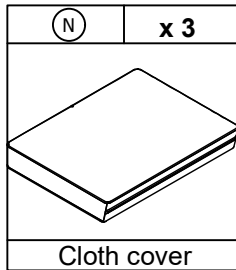
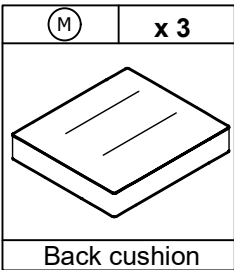
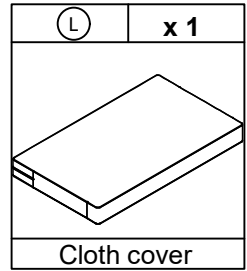
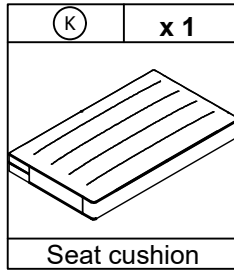
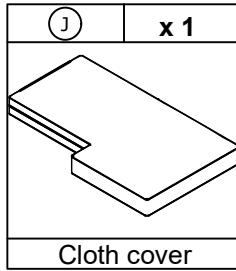
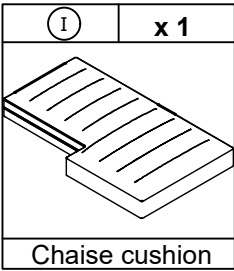
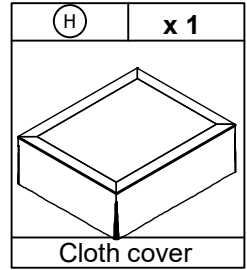
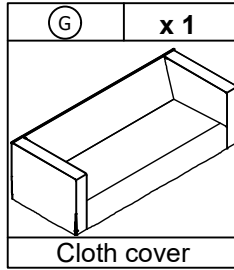
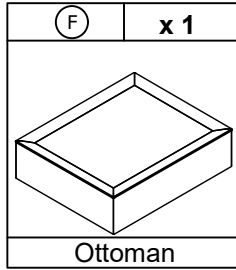
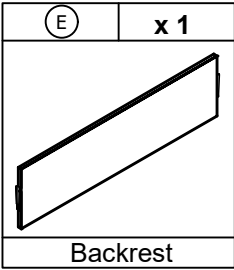
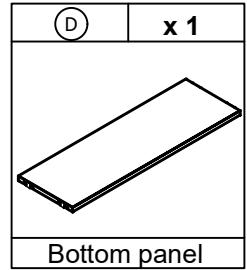
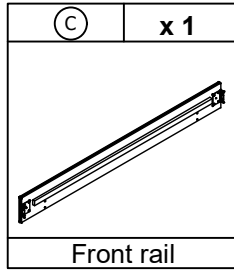
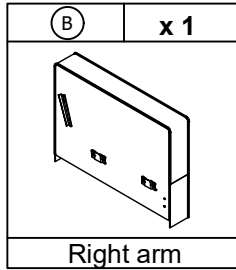
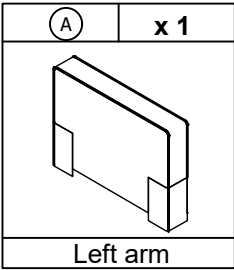

HARDWARE LIST

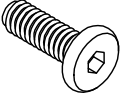
1	x 6
	
Bolt	
φ5/16" X 23mm	

TOOL LIST

2	x 1
	
Allen Key	
M5	

HARDWARE SPARE LIST

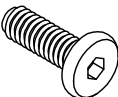
1	x 1
	
Bolt	
φ5/16" X 23mm	

ASSEMBLY INSTRUCTIONS

STEP-0



Unzip and take out
the Back Cushion x 1.

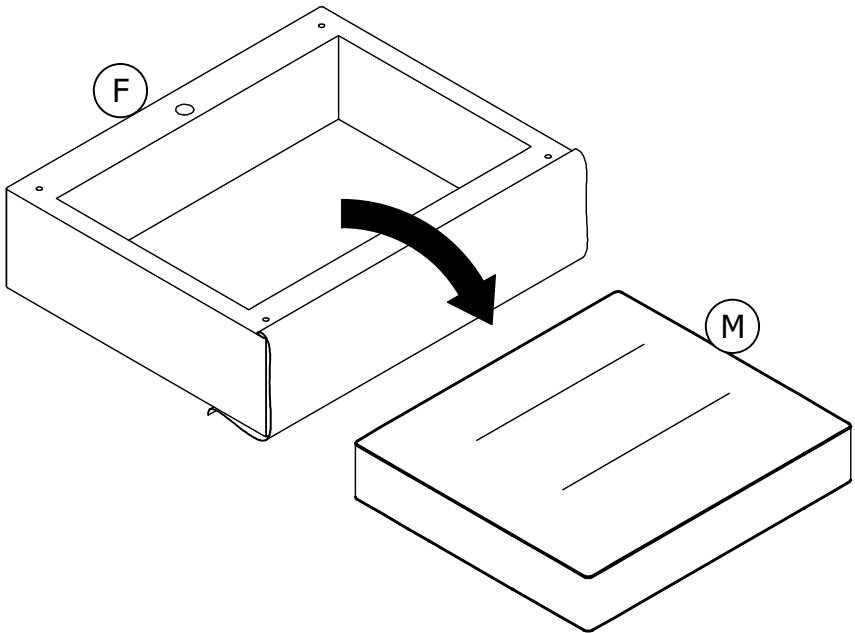

ASSEMBLY INSTRUCTIONS

STEP-1

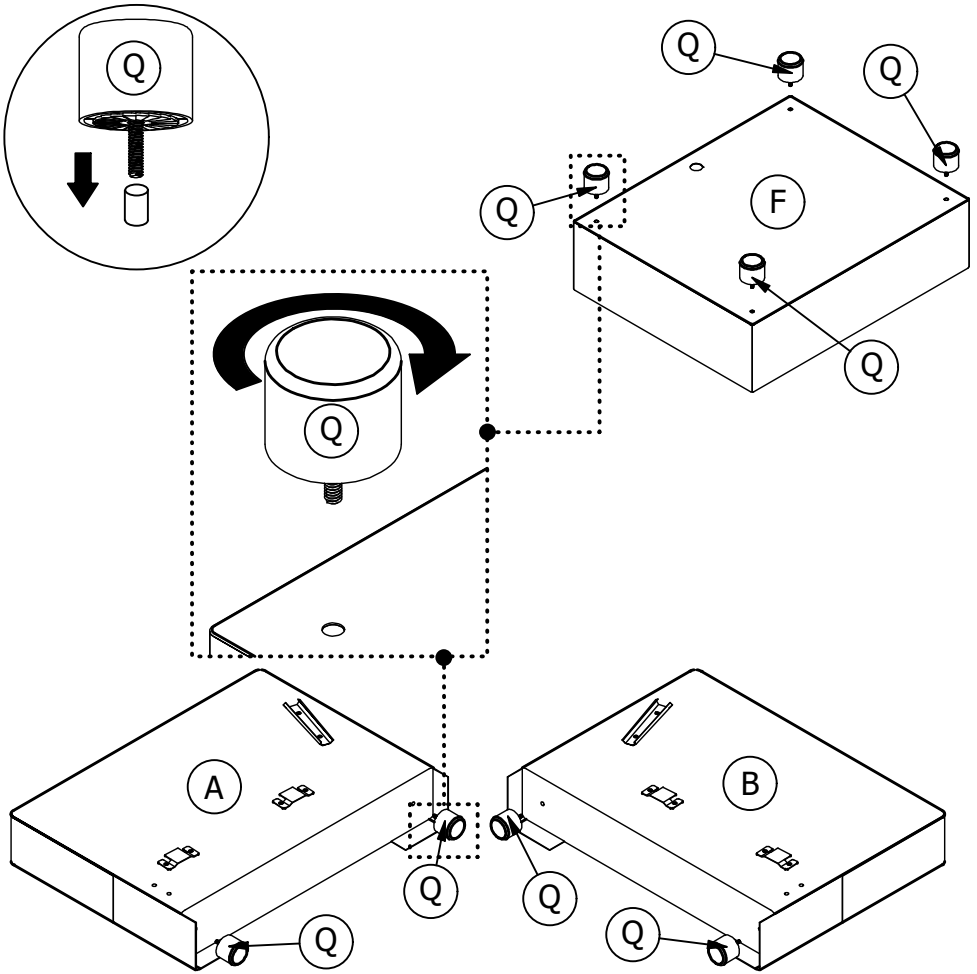

ASSEMBLY INSTRUCTIONS

STEP-2

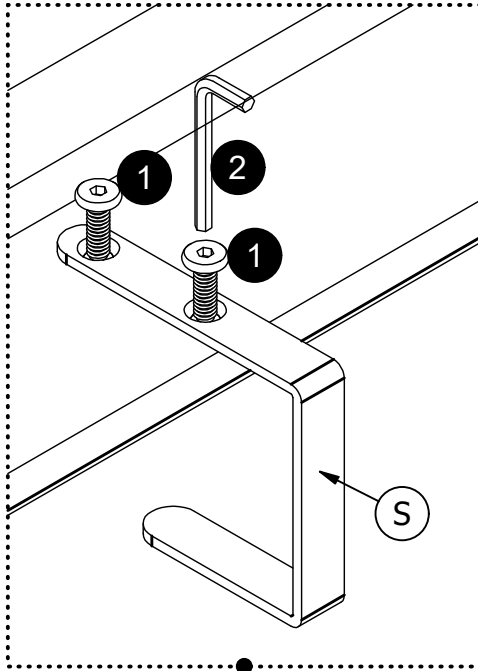

Connector **S** can be placed on either the left or right side of the Front Rail **C**.

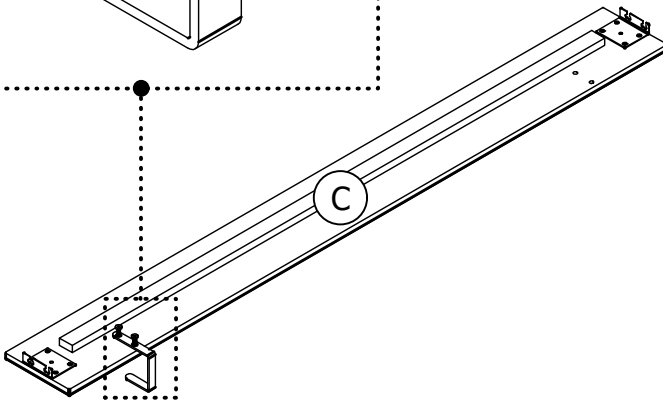

1	x 2
Bolt	
φ5/16" X 23mm	

2	x 1
Allen Key	
M 5	

ASSEMBLY INSTRUCTIONS

STEP-3

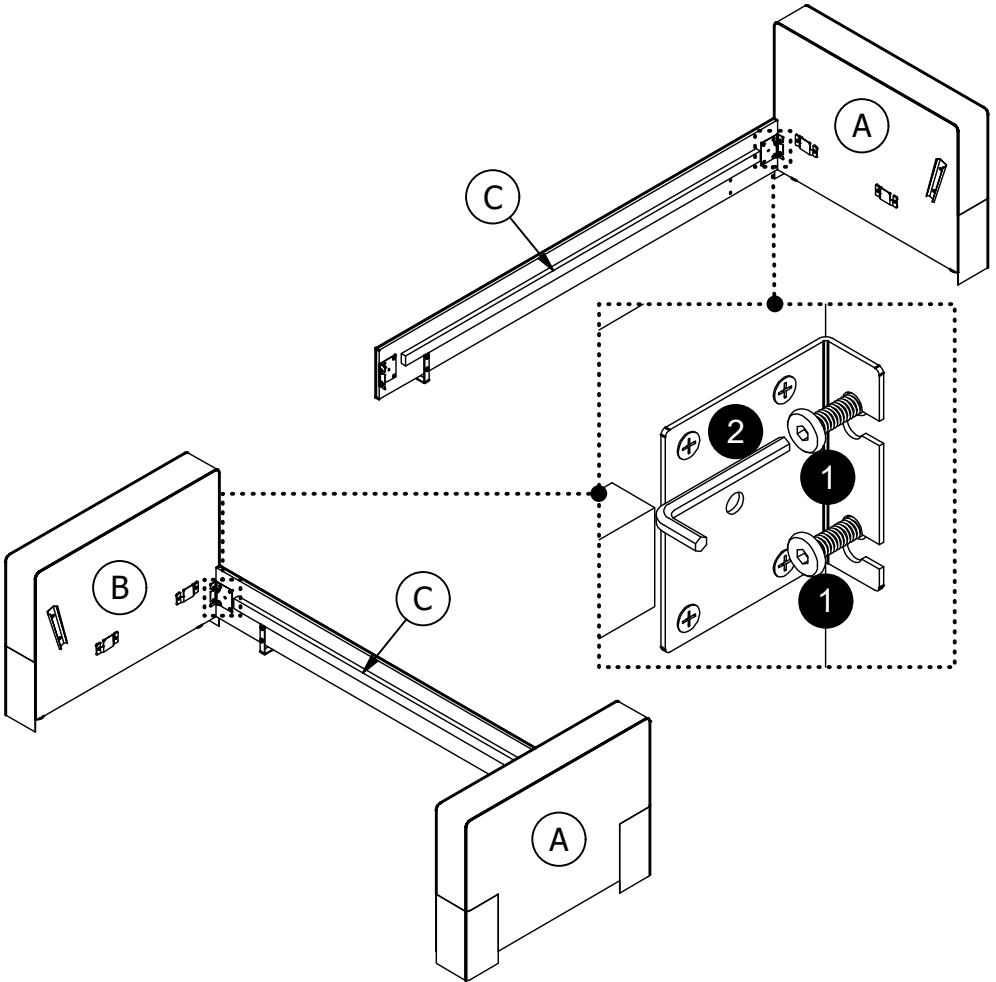

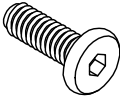
1	x 4
	
Bolt	
$\phi 5/16'' \times 23\text{mm}$	

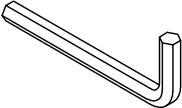
2	x 1
	
Allen Key	
M 5	

ASSEMBLY INSTRUCTIONS

STEP-4

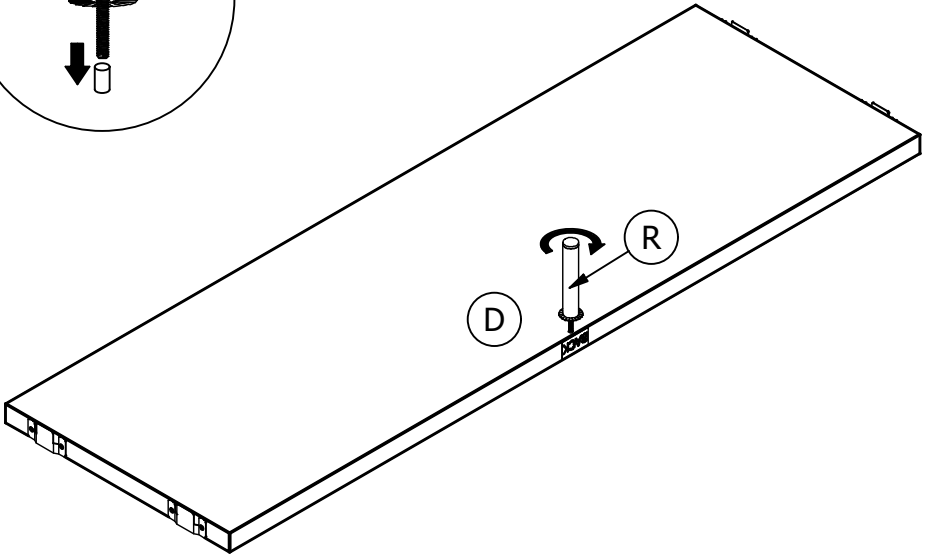
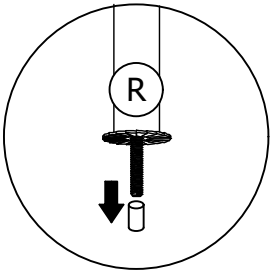

ASSEMBLY INSTRUCTIONS

STEP-5

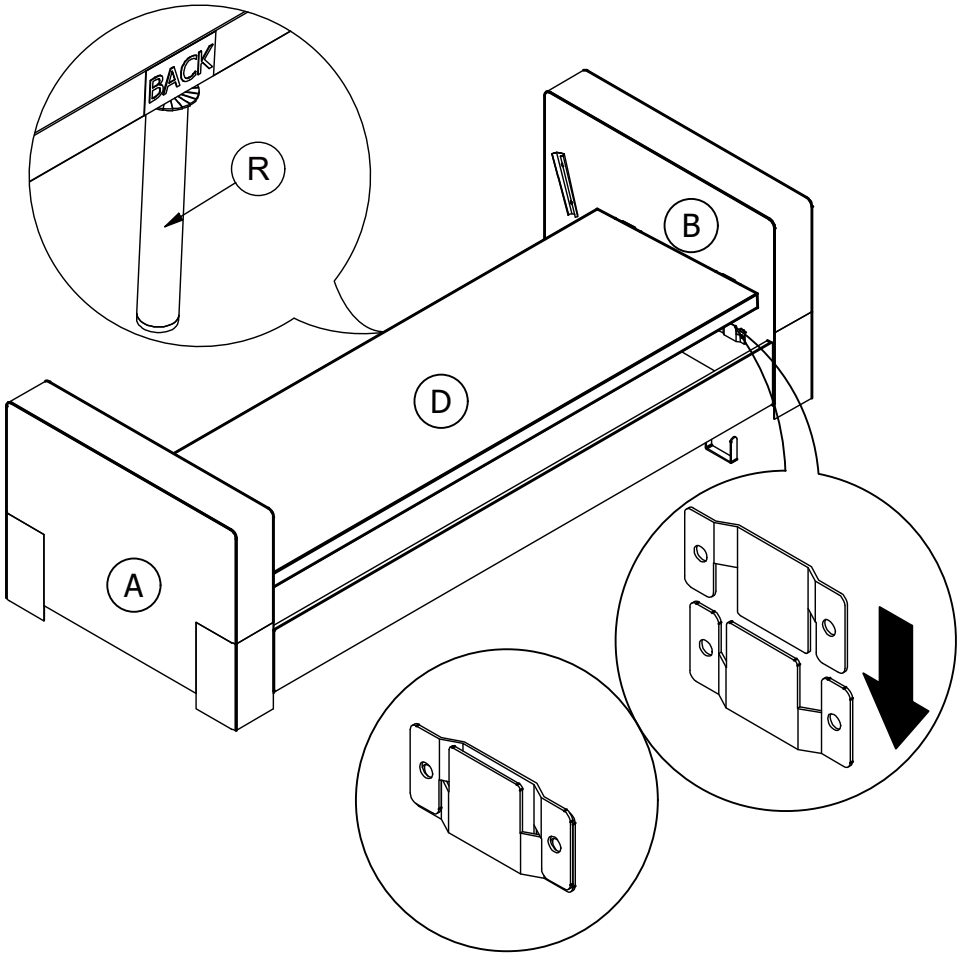

ASSEMBLY INSTRUCTIONS

STEP-6

Be sure to have adult partner help to hold both armrests while aligning metal brackets on backrest/armrests

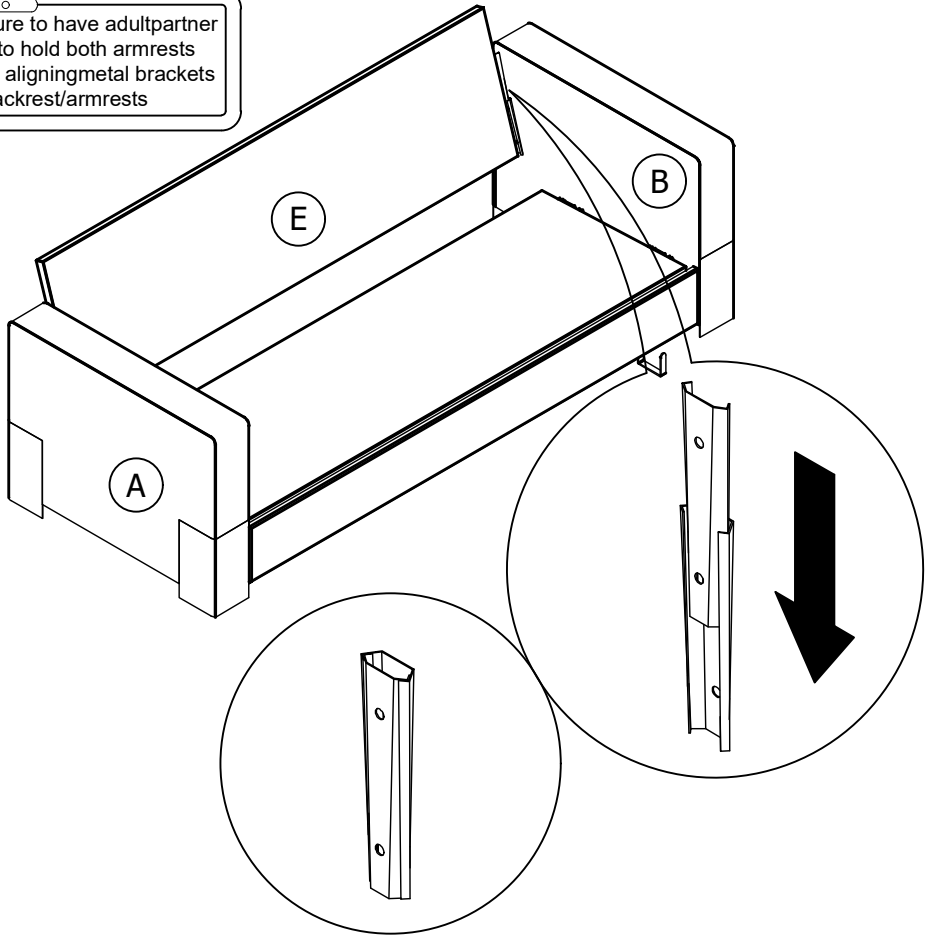

ASSEMBLY INSTRUCTIONS

STEP-7



If necessary, iron the fabric cover with a steam iron to loosen wrinkles.

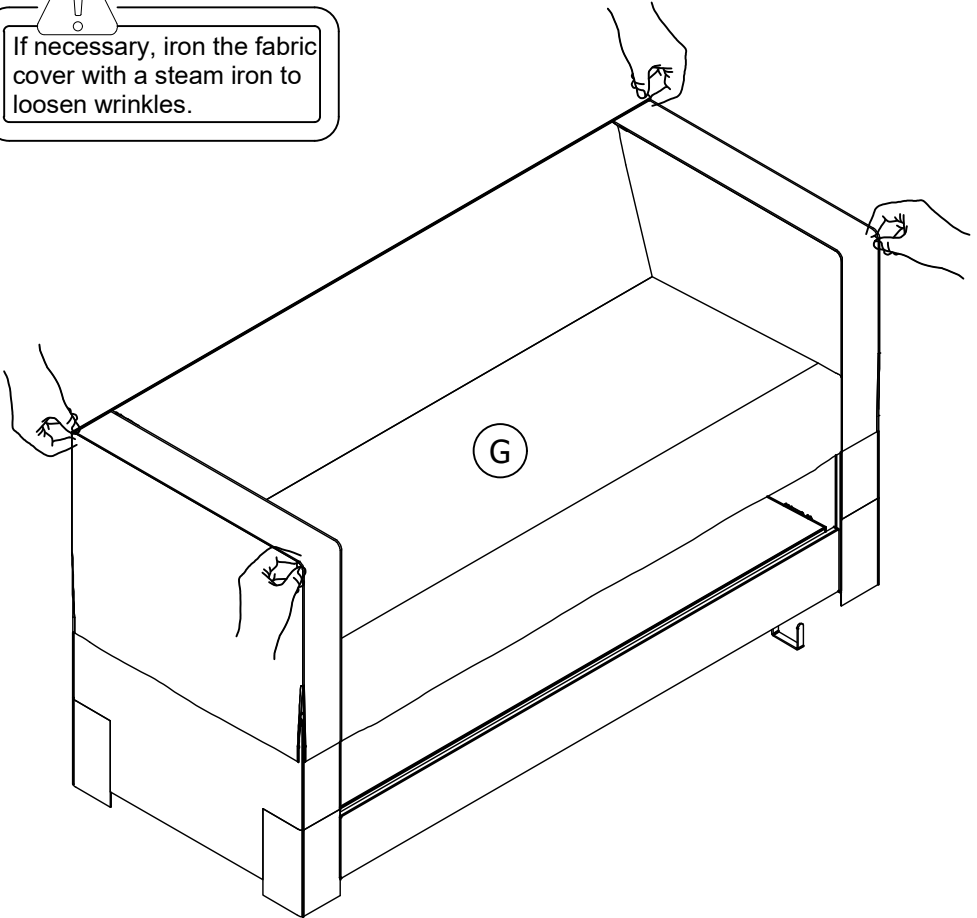

ASSEMBLY INSTRUCTIONS

STEP-8



If necessary, iron the fabric cover with a steam iron to loosen wrinkles.

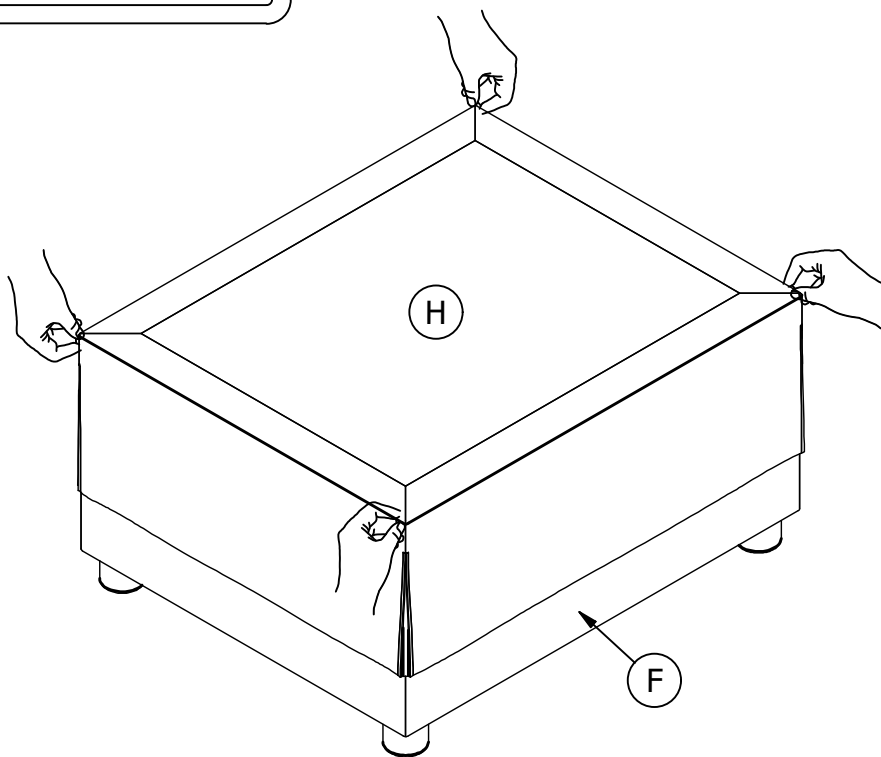

ASSEMBLY INSTRUCTIONS

STEP-9

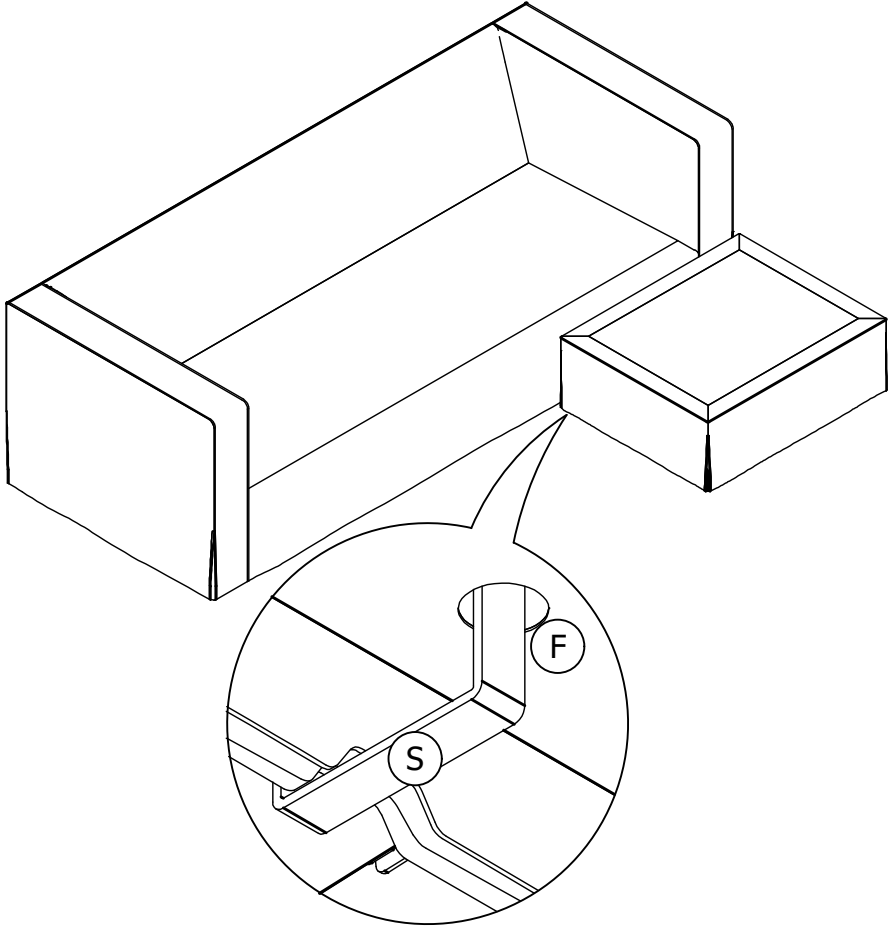

ASSEMBLY INSTRUCTIONS

STEP-10



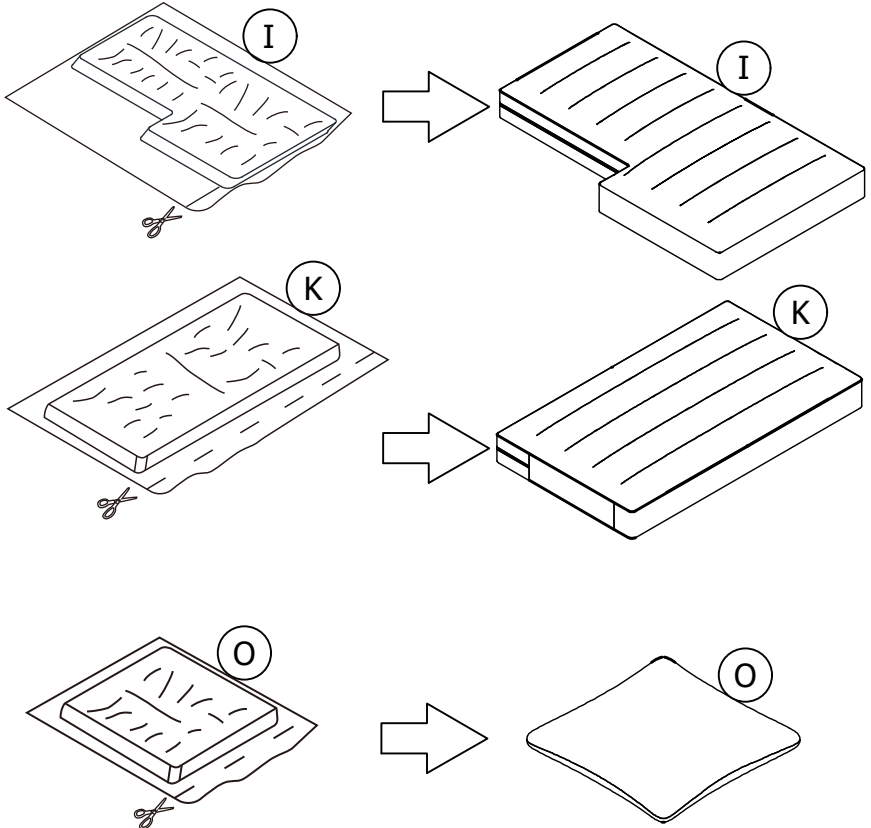

After unpacking all components, allow 48 hours for the compressed foam or polyester pillow fill to spring back. Blowing with a hair dryer or patting the mat with your hands will speed up the process.

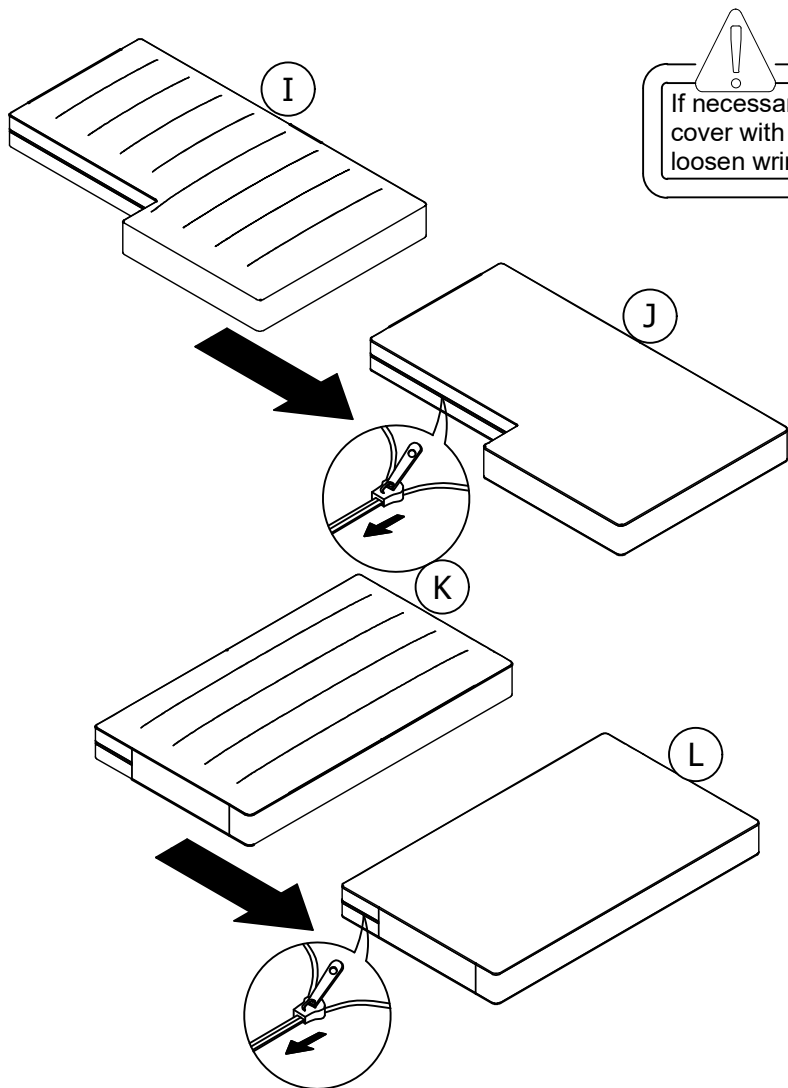

ASSEMBLY INSTRUCTIONS

STEP-11





If necessary, iron the fabric cover with a steam iron to loosen wrinkles.

ASSEMBLY INSTRUCTIONS

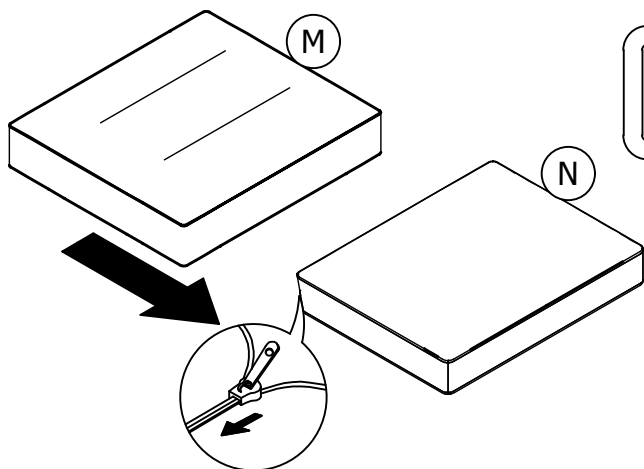
STEP-12



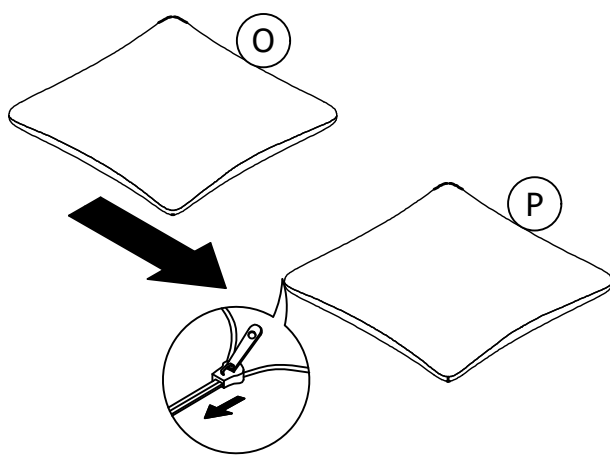

If necessary, iron the fabric cover with a steam iron to loosen wrinkles.

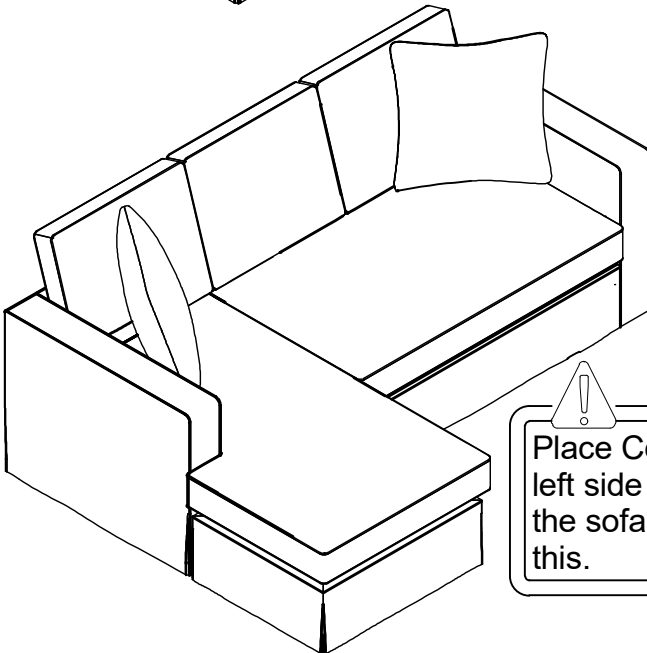
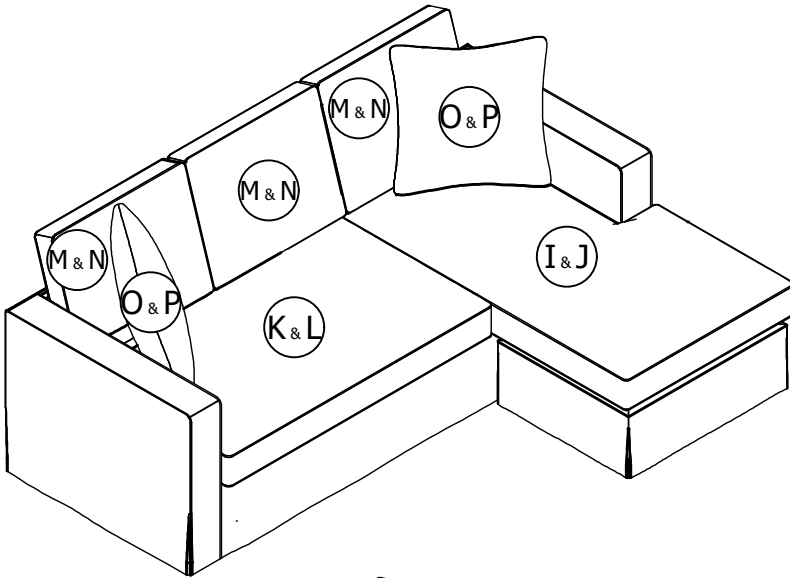

ASSEMBLY INSTRUCTIONS

STEP-13



Place Connector **S** on the left side of the Front Rail **C**, the sofa will become like this.

WARRANTY

1. We strive to offer high-quality products, and we also try our best to satisfy each and every customer that orders from us with product or service as needed.
2. We provide 30 days warranty starting from the time you receive the item. Each customer must provide a record of their order such as the order number, or item receipt for any items that are out of the warranty period you may also still receive.
3. Replacement parts by purchasing them with our company if they are available.

Are you having difficulty
With assembly? Missing parts?
Please send email with your order No to
customerservice@hulalahome.com
For return, please check the return policy with
the retailer or market place you bought from.

Appreciate your purchasing from us.
Pop up your life by our furniture piece!